

LUNCHEON LEARN

Measuring Threaded Holes

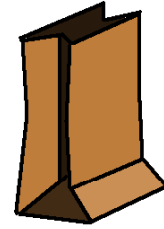

LUNCHEON LEARN

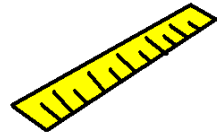
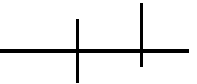
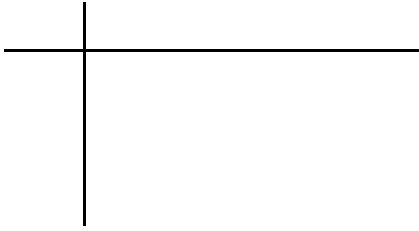

It's a common question...

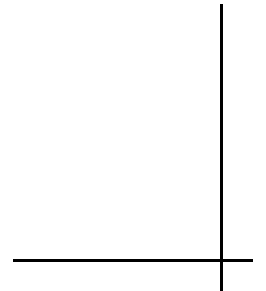

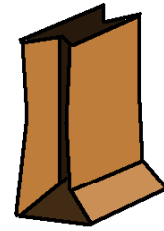
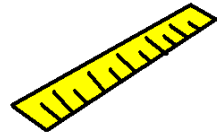

LUNCHEON LEARN

In PC-DMIS I can use the pitch function within a circle feature so the probe would "follow" the thread. How are tapped holes measured in Calypso?

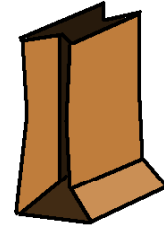
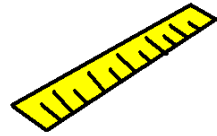

LUNCHEON LEARN

I have a part with several threaded holes that I need to report TP on.

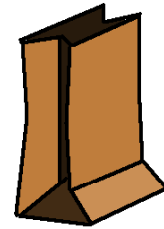
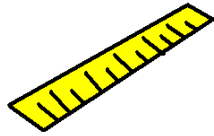

LUNCHEON LEARN

what is the best method of checking the position of threaded holes, i would like to stay away from flex plugs due to cmm time.

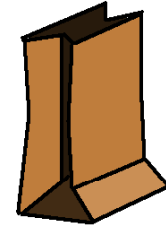
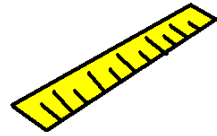

LUNCHEON LEARN

We have been checking a thread hole and they screwed a pin in the hole and were measuring od of pin for T/P. I've been trying to revise the program to check without pin to save some time. I am having trouble getting results.

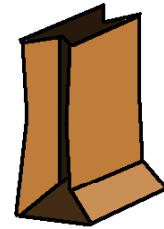
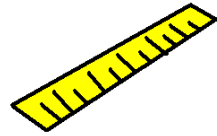

LUNCHEON LEARN

Why the problems?

Here's how a
common thread is
made:

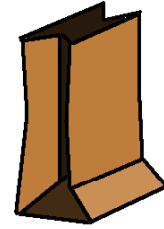
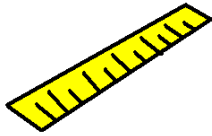

LUNCHEON LEARN

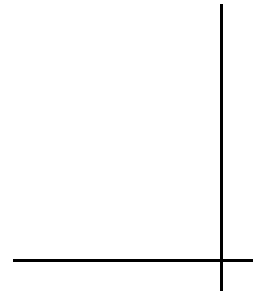
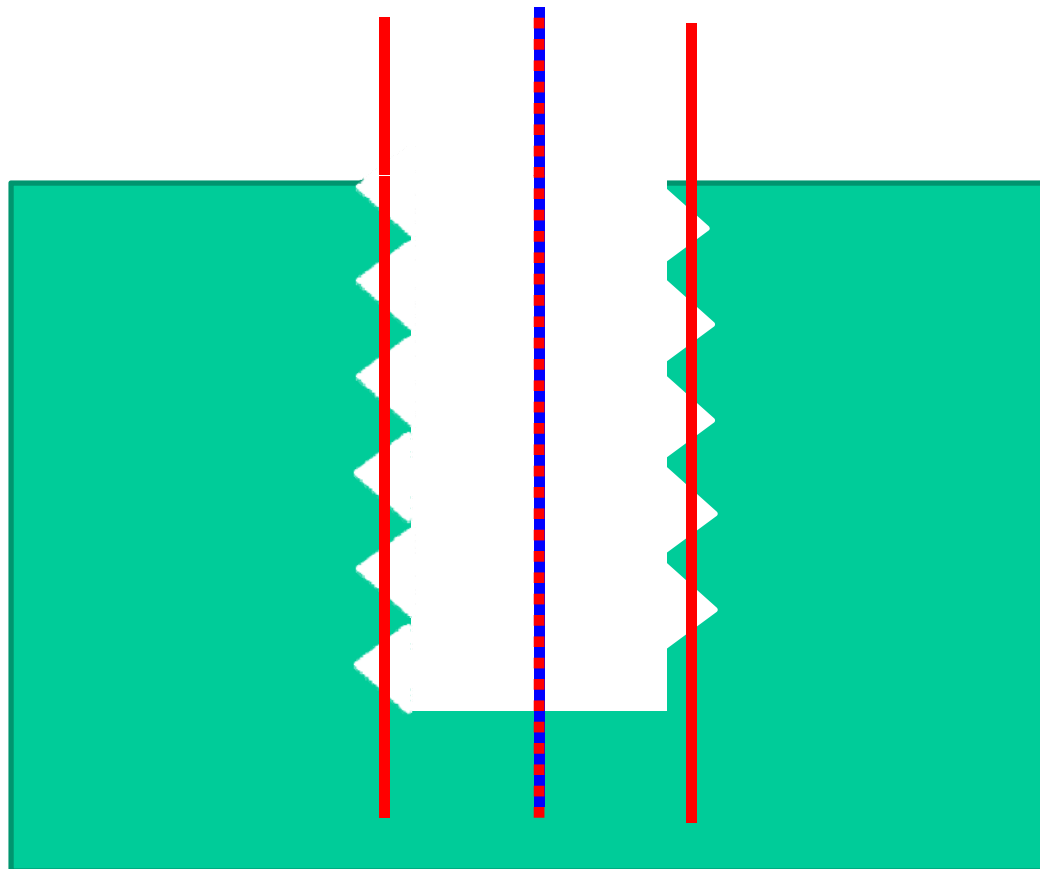
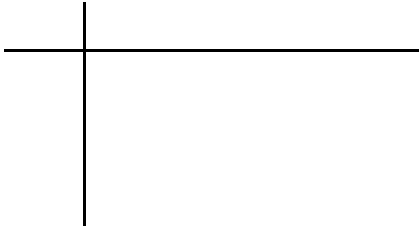

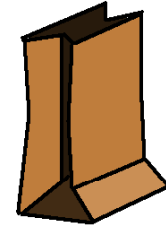
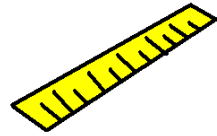

LUNCHEON LEARN

In a perfect world, pilot hole location (which we don't care about) is the same as the pitch location (which we care about)

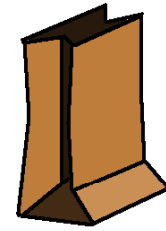
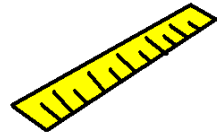

LUNCHEON LEARN

If you haven't noticed yet, this is not a perfect world...

Real parts can look like this:

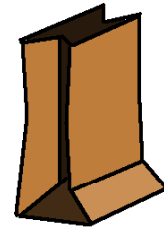
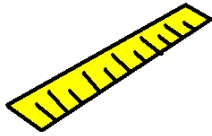

LUNCHEON LEARN

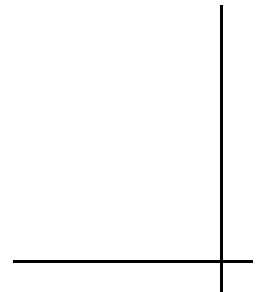
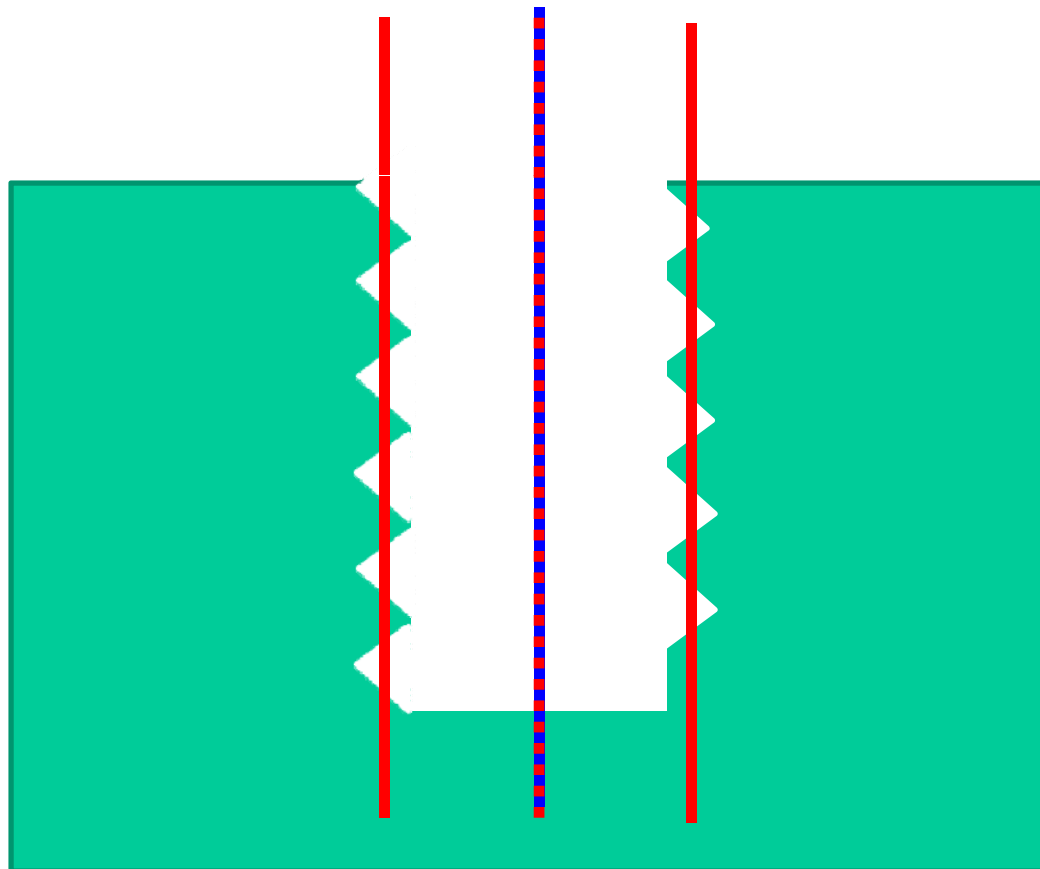
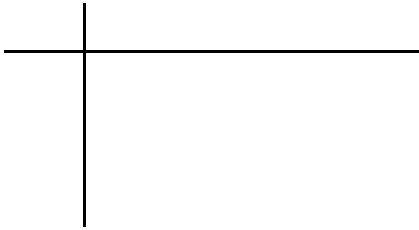

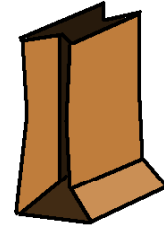
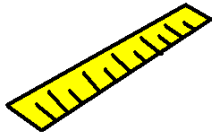

LUNCHEON LEARN

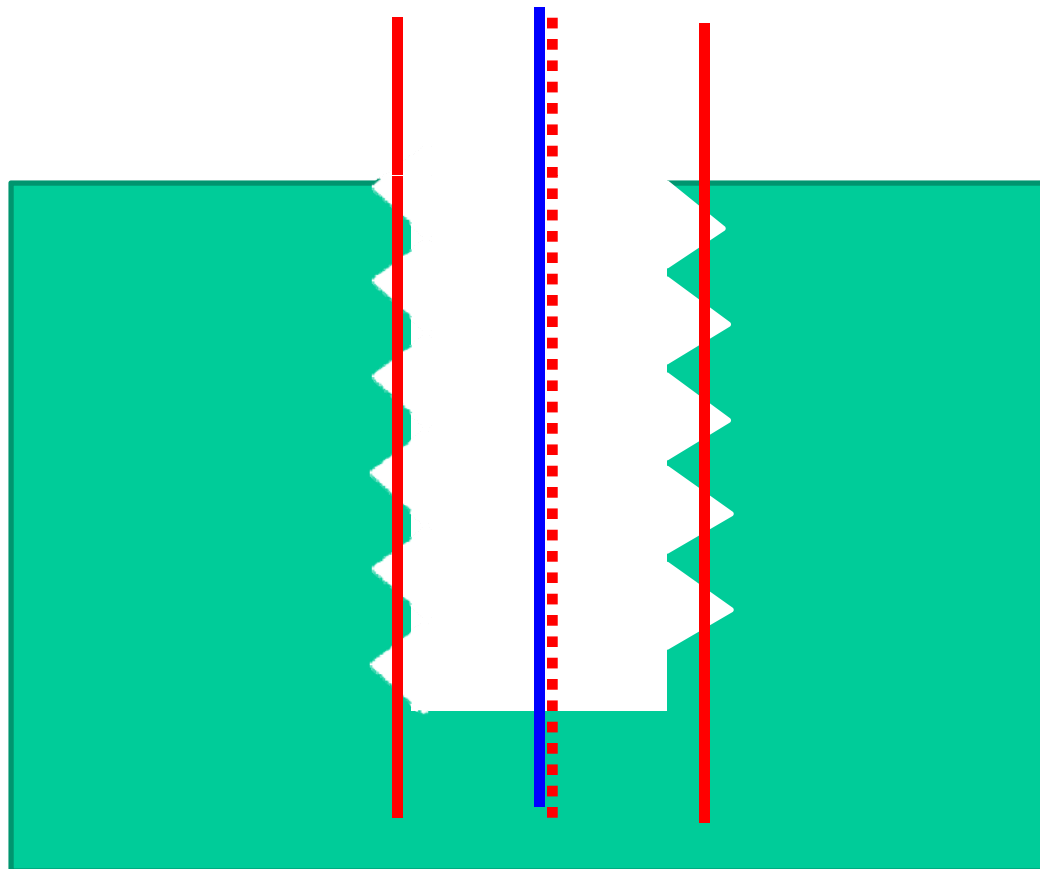

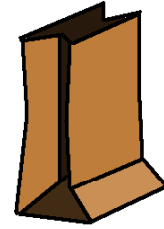
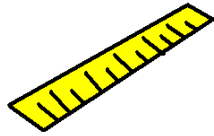

LUNCHEON LEARN

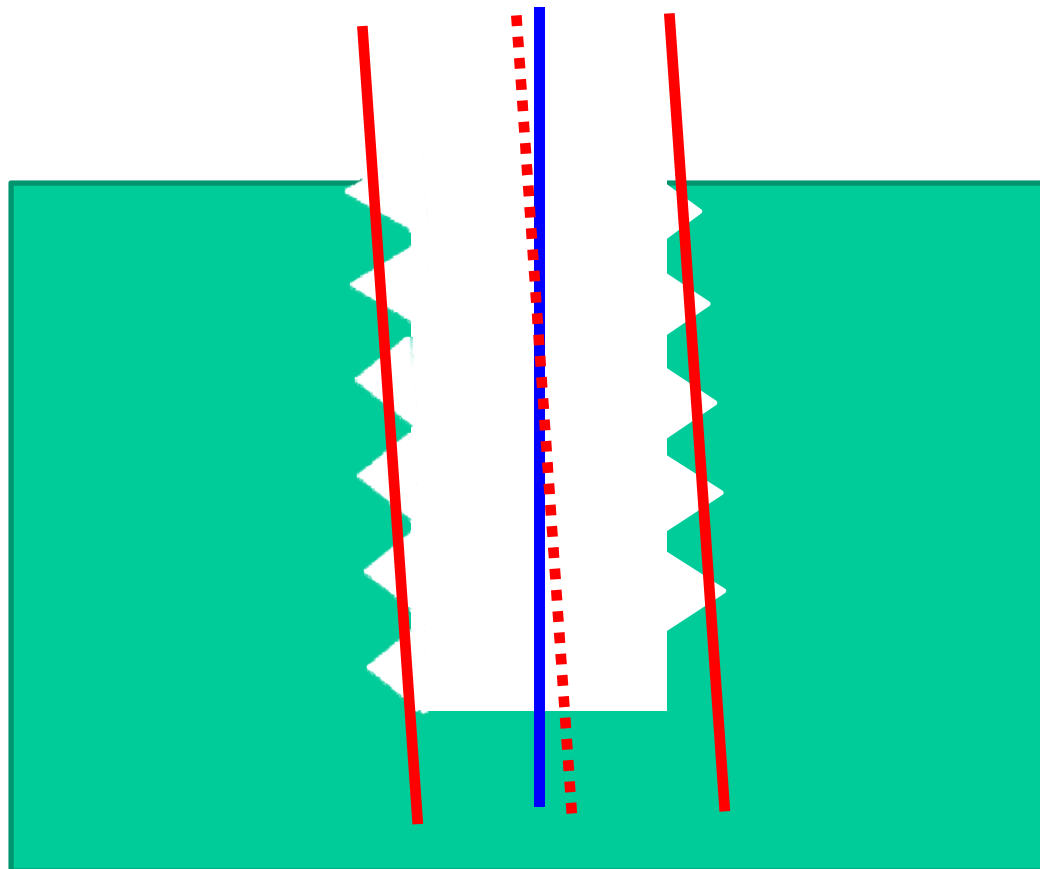

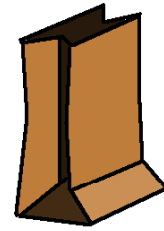
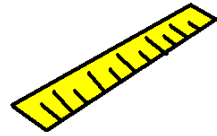

LUNCHEON LEARN

We can't directly
measure the pitch
diameter on a CMM.

What's a CMM
programmer to do?

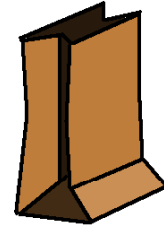
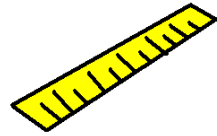

LUNCHEON LEARN

The traditional
“accepted” method is to
use a Thread Location
gage.

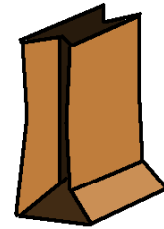
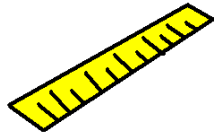

LUNCHEON LEARN

Threaded Hole Centerline Gages



Flexible



Solid



Tapered



Thread Lock



Variable

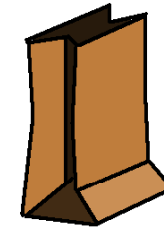
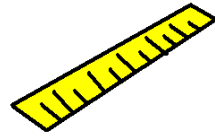

LUNCHEON LEARN

Centerline Hole Location Gages

Threaded hole location plugs are slotted* every 90° around the plug, and the pitch diameter is ground to assure positive location at the pitch diameter of the part being checked. Use to check centerline distance between two or more tapped holes. Normally used in pairs. Concentric to P.D. .0002 T.I.R.

Size (Inch)	EDP No.	Price
0-80 UNF	480100	90.00
1-64 UNC	480200	87.00
1-72 UNF	480300	87.00
2-56 UNC	480400	85.00
2-64 UNF	480500	85.00
3-48 UNC	480600	81.00
3-56 UNF	480700	81.00
4-40 UNC	480900	76.00
4-48 UNF	481000	76.00
5-40 UNC	481100	83.00
5-44 UNF	481200	83.00
6-32 UNC	481300	84.00
6-40 UNF	481400	84.00
8-32 UNC	481500	79.00
8-36 UNF	481600	79.00
10-24 UNC	481700	78.00
10-32 UNF	481800	78.00
12-24 UNC	481900	76.00

Size (Inch)	EDP No.	Price
5/16-18 UNC	482500	68.00
5/16-24 UNF	482600	68.00
3/8-16 UNC	482800	72.00
3/8-24 UNF	482900	72.00
7/16-14 UNC	483100	70.00
7/16-20 UNF	483200	70.00
1/2-13 UNC	483400	75.00
1/2-20 UNF	483500	75.00
9/16-12 UNC	483700	74.00
9/16-18 UNF	483800	74.00
5/8-11 UNC	484000	76.00
5/8-18 UNF	484100	76.00
3/4-10 UNC	484400	80.00
3/4-16 UNF	484500	80.00
7/8-9 UNC	484800	93.00
7/8-14 UNF	484900	93.00
1-8 UNC	485200	132.00
1-12 UNF	485300	132.00

Size (Metric)	EDP No.	Price
M4 X .7	487500	95.00
M5 X .8	487600	89.00
M6 X 1.0	487700	80.00
M8 X 1.25	487800	80.00
M10 X 1.5	488000	84.00
M12 X 1.75	488300	85.00
M12 X 1.25	488500	86.00

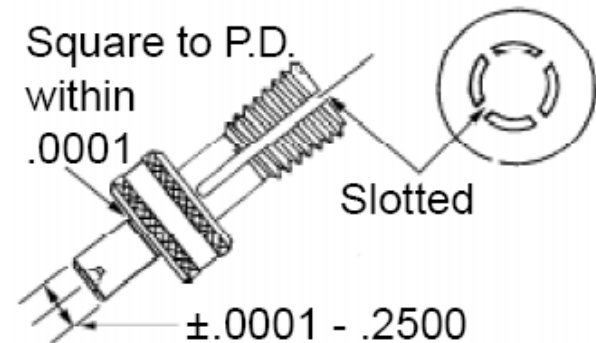

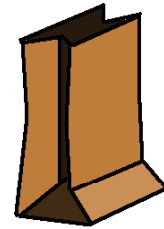
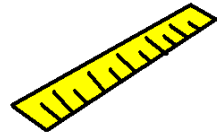

LUNCHEON LEARN

“precision”
cylinder to be
measured by the
CMM.

Split threads
spring tight into
the pitch
diameter.



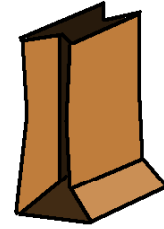
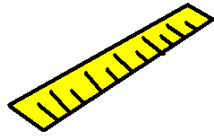

LUNCHEON LEARN

Let's Test it out!

(Accura, 0.050mm tolerance)

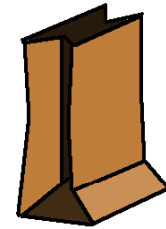
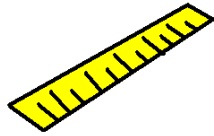

LUNCHEON LEARN

Calypso User Desk - (C) Carl Zeiss - TP Thread with Gage

File Edit View Resources Features Construction Size Form and Location Plan CAD Extras Planner Window ?

#1 down

Basic Status: Select function or probe for surface measurement with single points

- True Position Intersection
- True Position Cylinder
- True Position Cylinder Top
- True Position Cylinder Bottom
- True Position Circle



20 mm

Fit

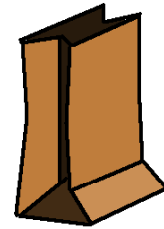
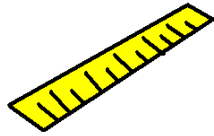
The screenshot displays the Calypso software interface. The main window shows a 3D model of a part with a coordinate system (X, Y, Z) and a measurement tool (probe) positioned at a point on the surface. The left sidebar contains a list of measurement functions, with 'True Position Circle' selected. The bottom status bar shows the current measurement value as '20 mm' and the 'Fit' button.

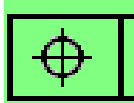
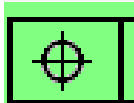
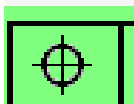
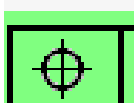

LUNCHEON LEARN

-  True Position Intersection
-  True Position Cylinder
-  True Position Cylinder Top
-  True Position Cylinder Bottom
-  True Position Circle

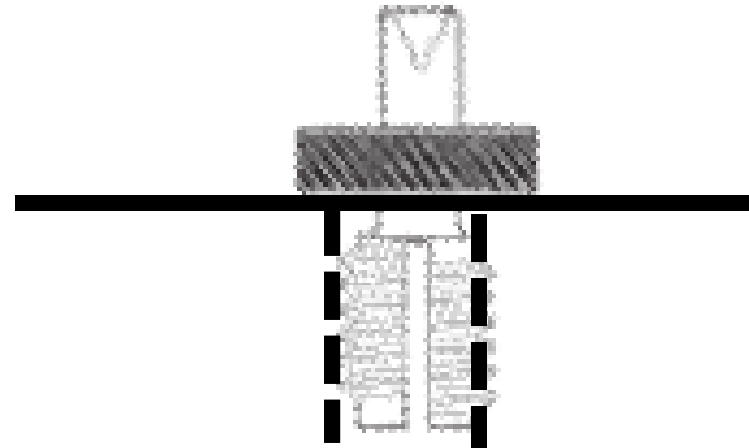

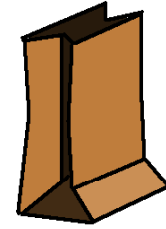
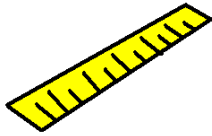

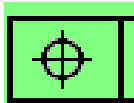
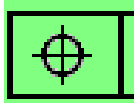
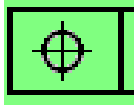
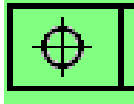
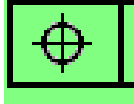

LUNCHEON LEARN

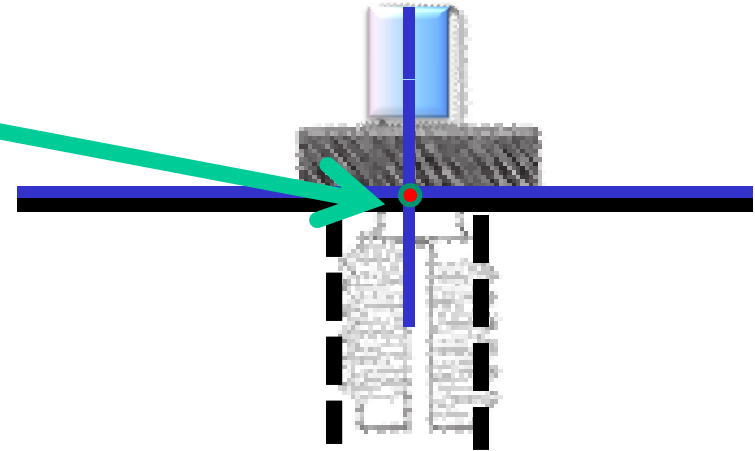
-  True Position Intersection
-  True Position Cylinder
-  True Position Cylinder Top
-  True Position Cylinder Bottom
-  True Position Circle

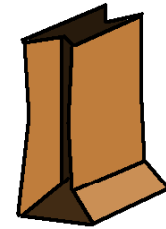
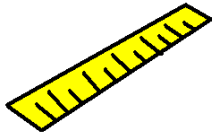



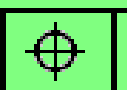
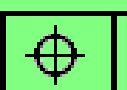
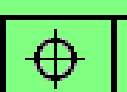
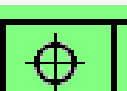

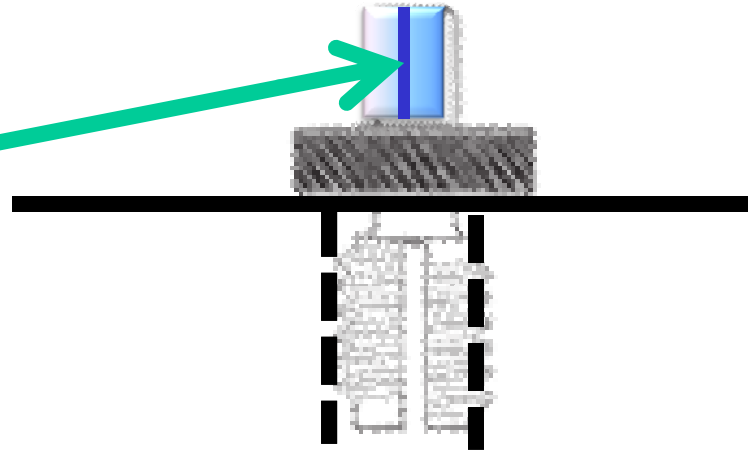
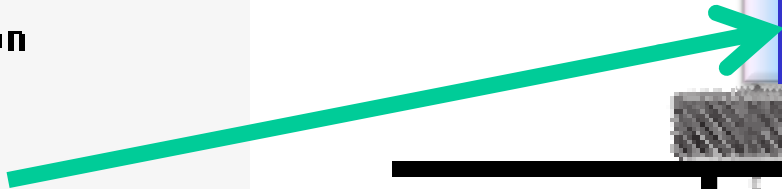

LUNCHEON LEARN

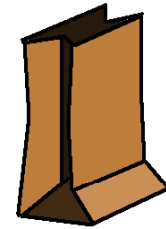
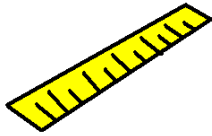
-  True Position Intersection
-  True Position Cylinder
-  True Position Cylinder Top
-  True Position Cylinder Bottom
-  True Position Circle





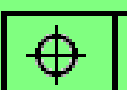
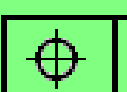

LUNCHEON LEARN

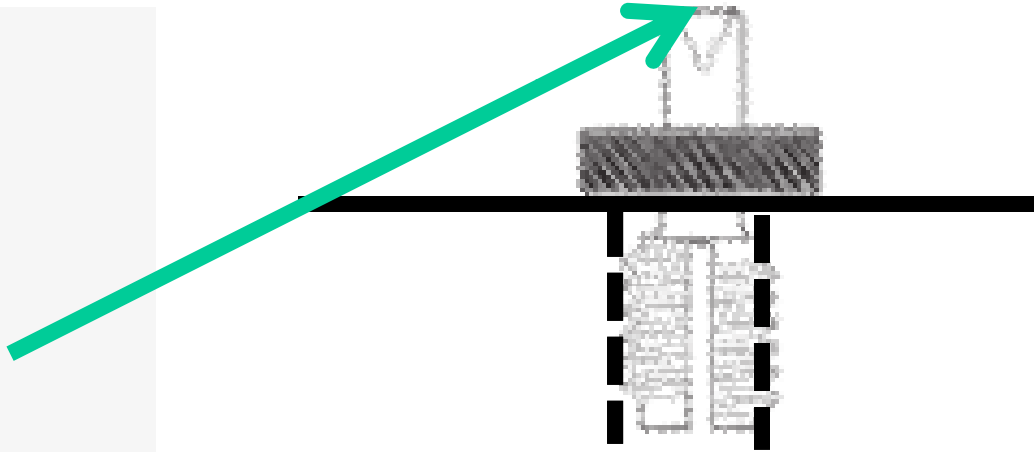
-  True Position Intersection
-  True Position Cylinder
-  True Position Cylinder Top
-  True Position Cylinder Bottom
-  True Position Circle

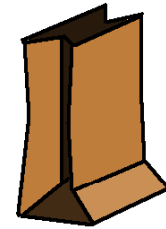
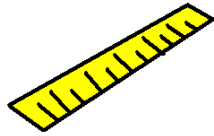



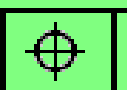
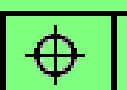
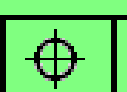
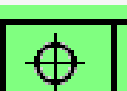

LUNCHEON LEARN

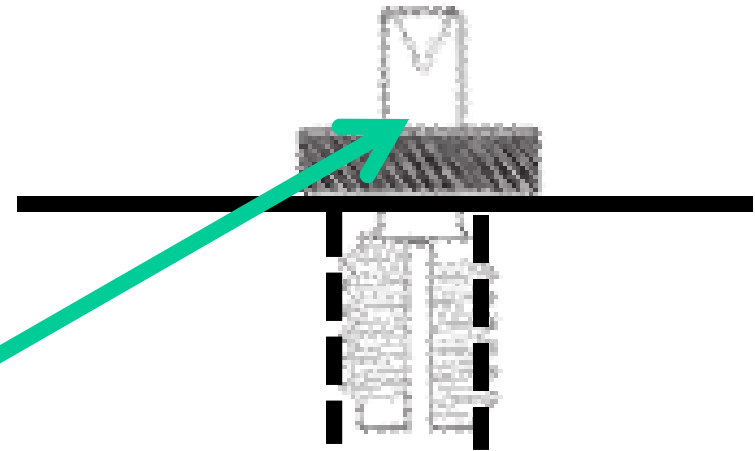
-  True Position Intersection
-  True Position Cylinder
-  True Position Cylinder Top
-  True Position Cylinder Bottom
-  True Position Circle

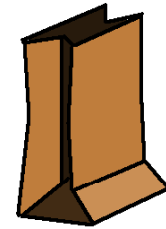
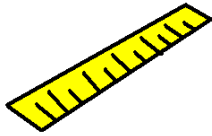

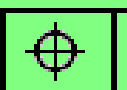
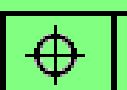
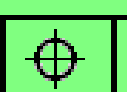
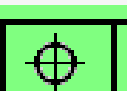

LUNCHEON LEARN

-  True Position Intersection
-  True Position Cylinder
-  True Position Cylinder Top
-  True Position Cylinder Bottom
-  True Position Circle

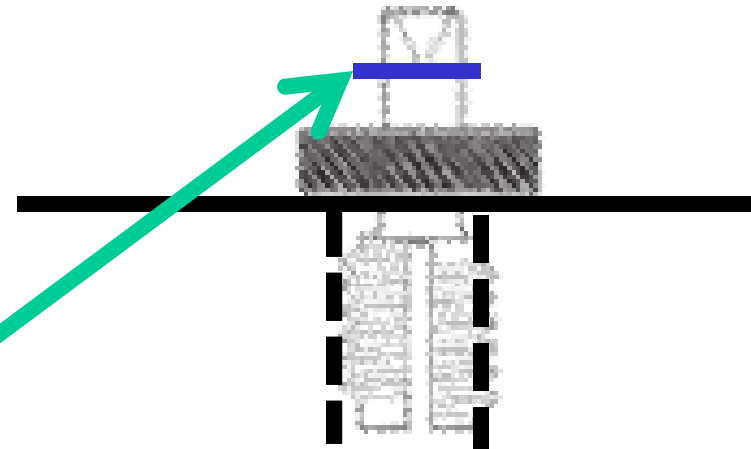

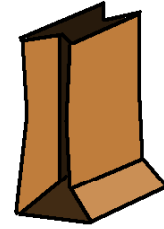
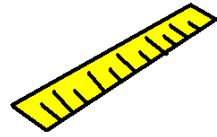

LUNCHEON LEARN

Run it 10 times in the
same place to prove
program repeatability...

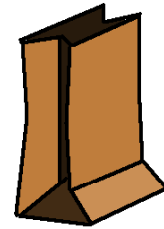
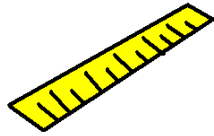

LUNCHEON LEARN

True Position Cylinder Bottom

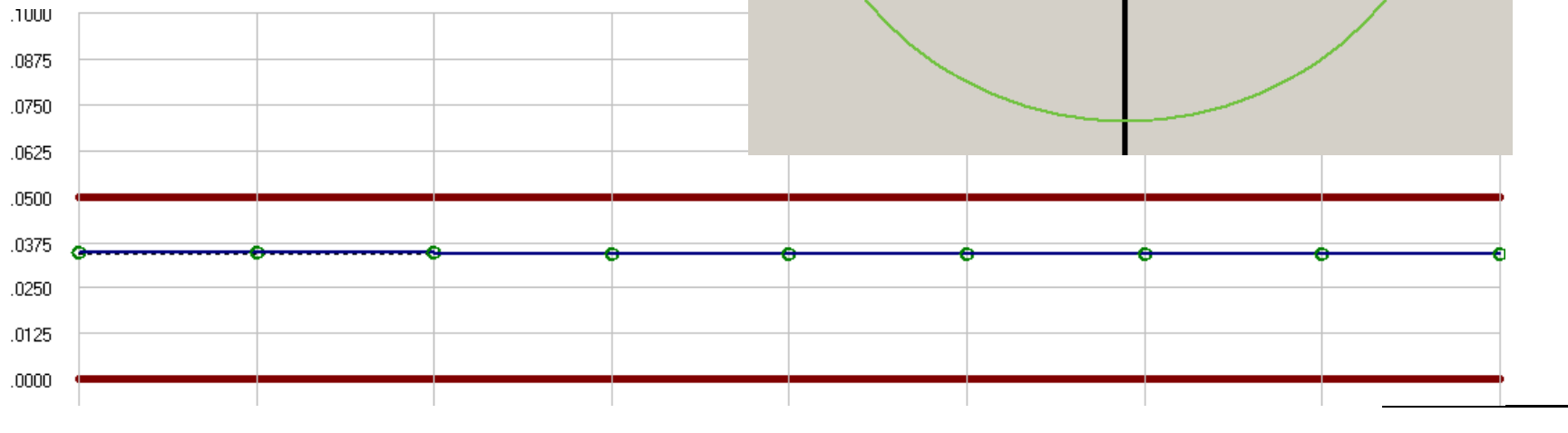
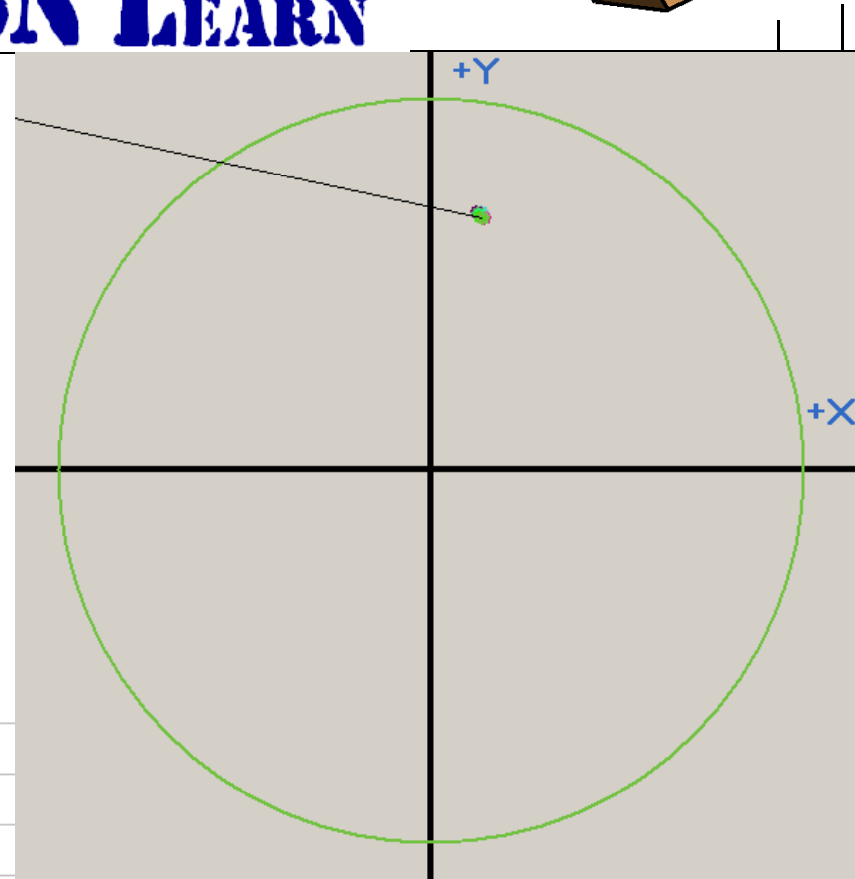

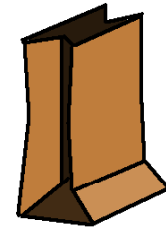
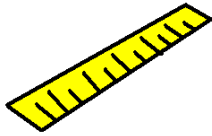

LUNCHEON LEARN

True Position Circle

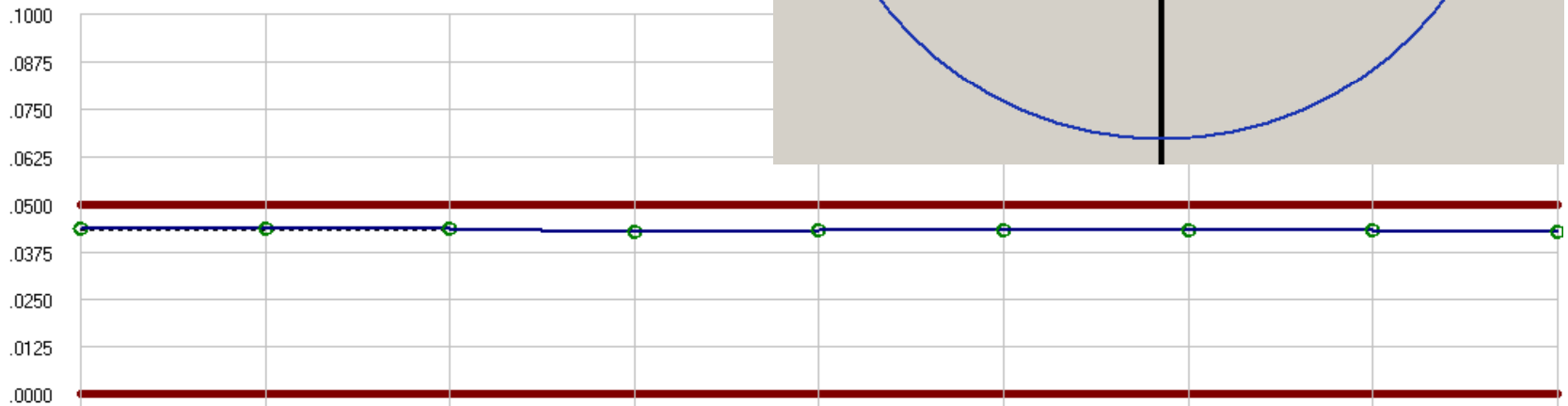
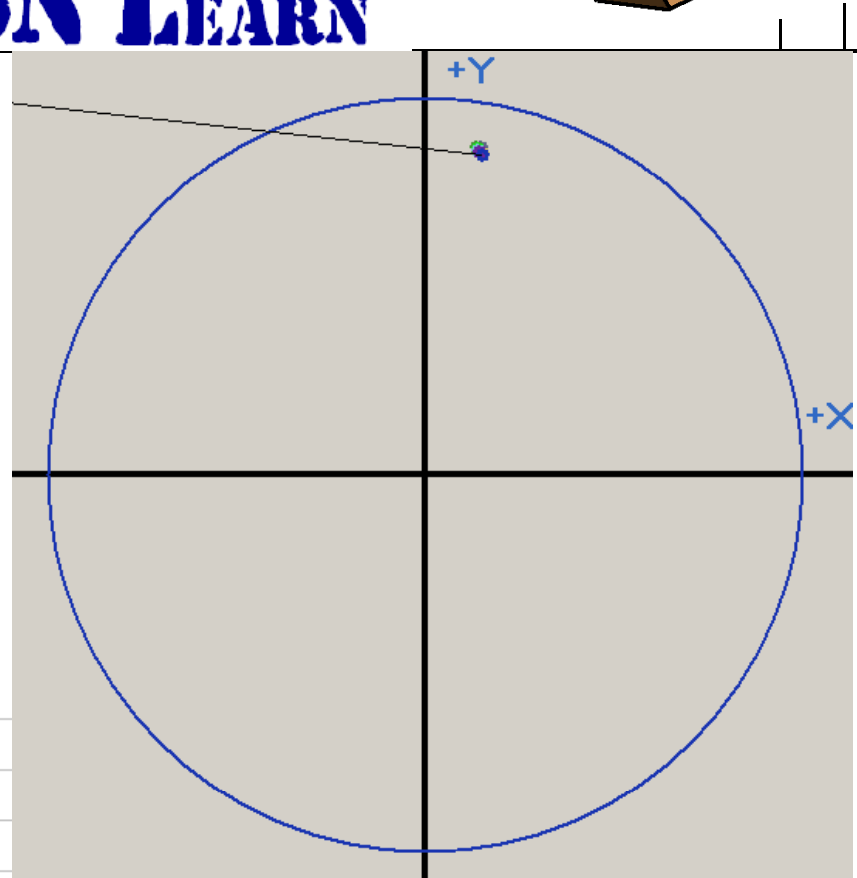

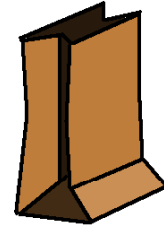
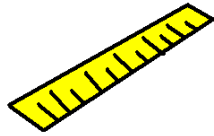

LUNCHEON LEARN

True Position Cylinder

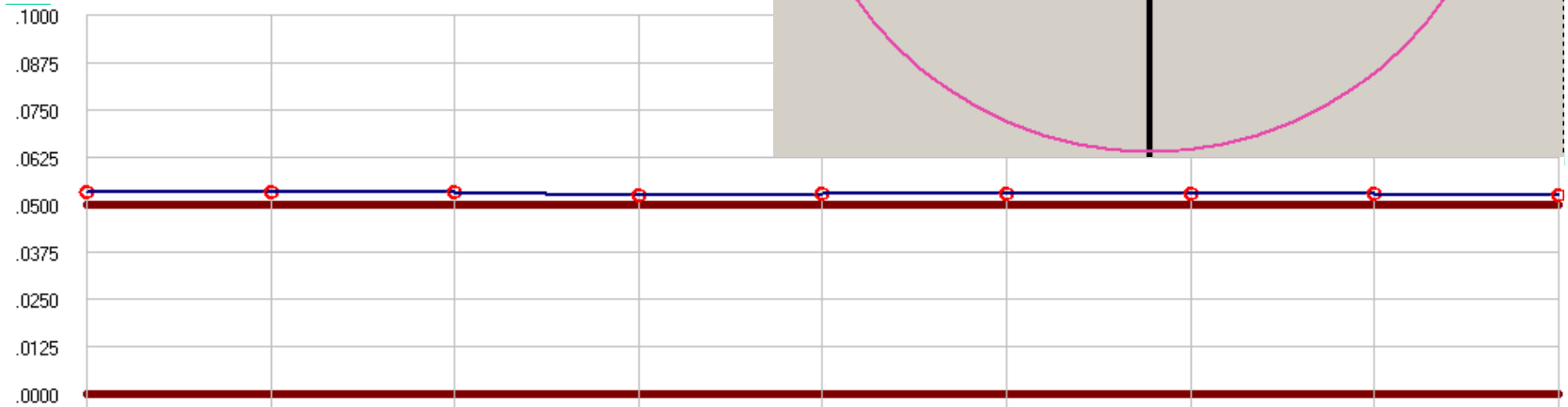
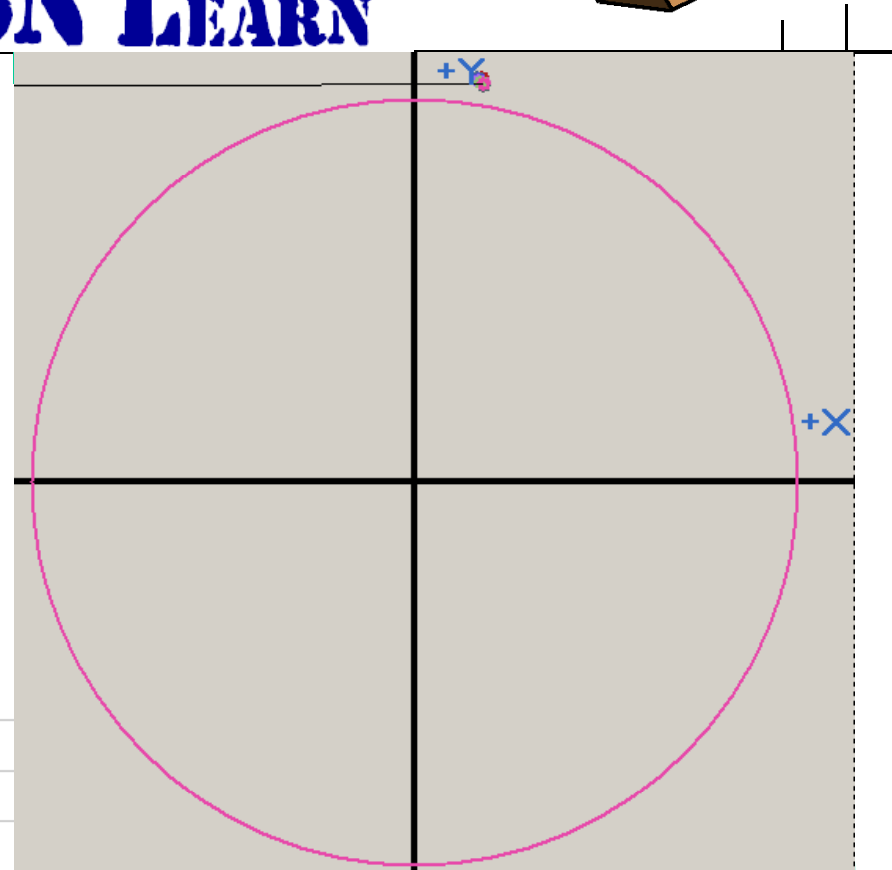

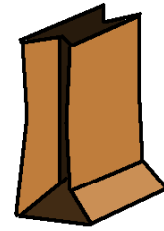
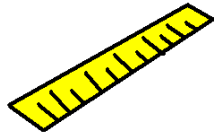

LUNCHEON LEARN

True Position Cylinder Top

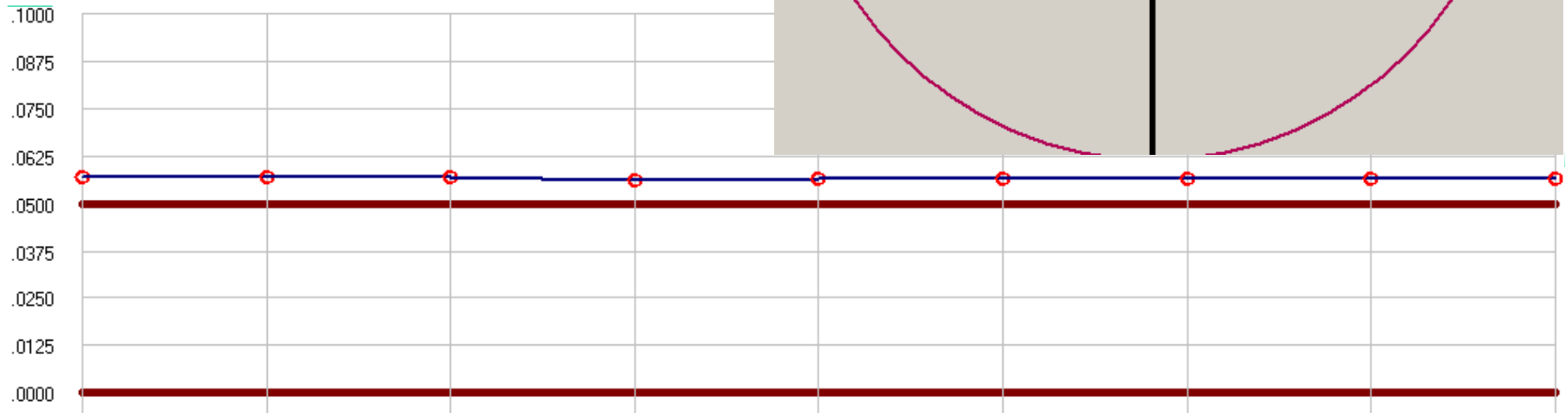
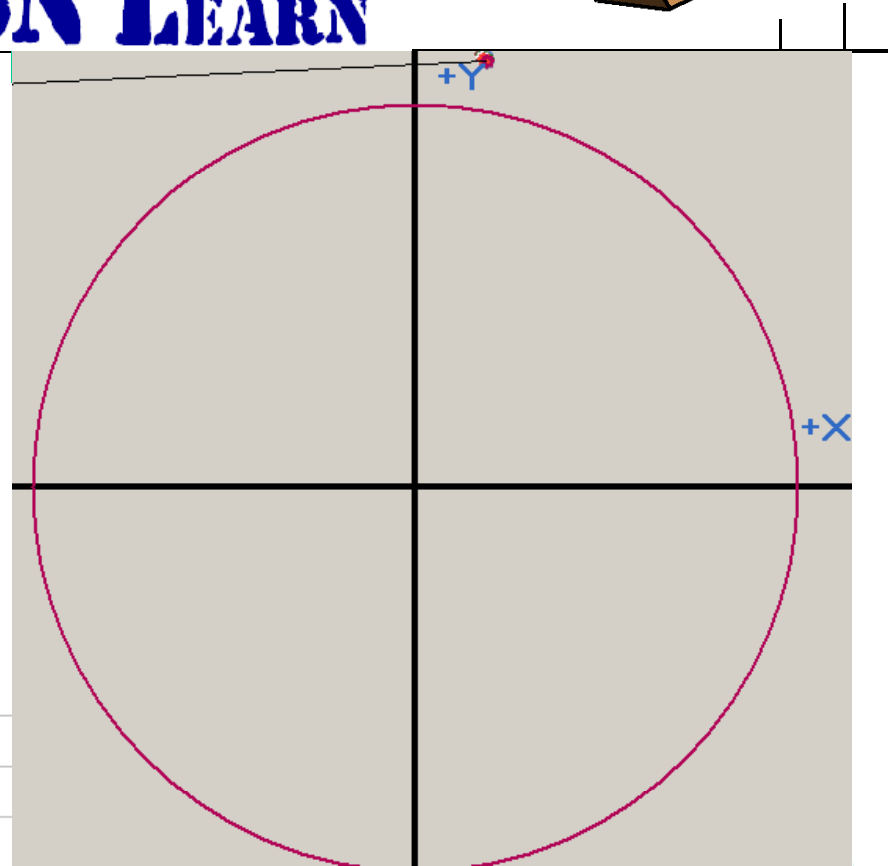

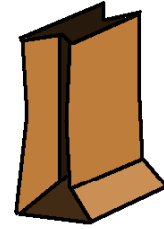
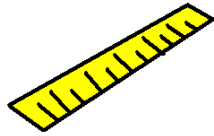

LUNCHEON LEARN

Good repeatability.
Program is fine.

Difference in answers
show a tilt of the thread.

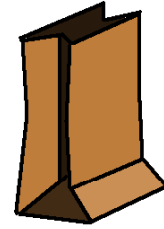
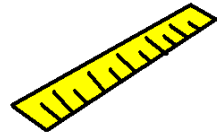

LUNCHEON LEARN

Run it 10 times and
reload to prove fixture
method...

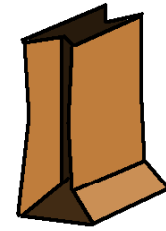
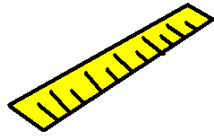

LUNCHEON LEARN

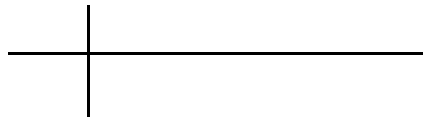

True Position Intersection

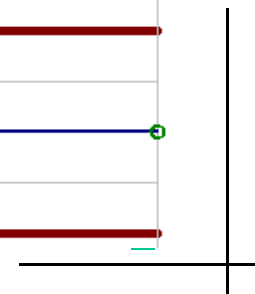
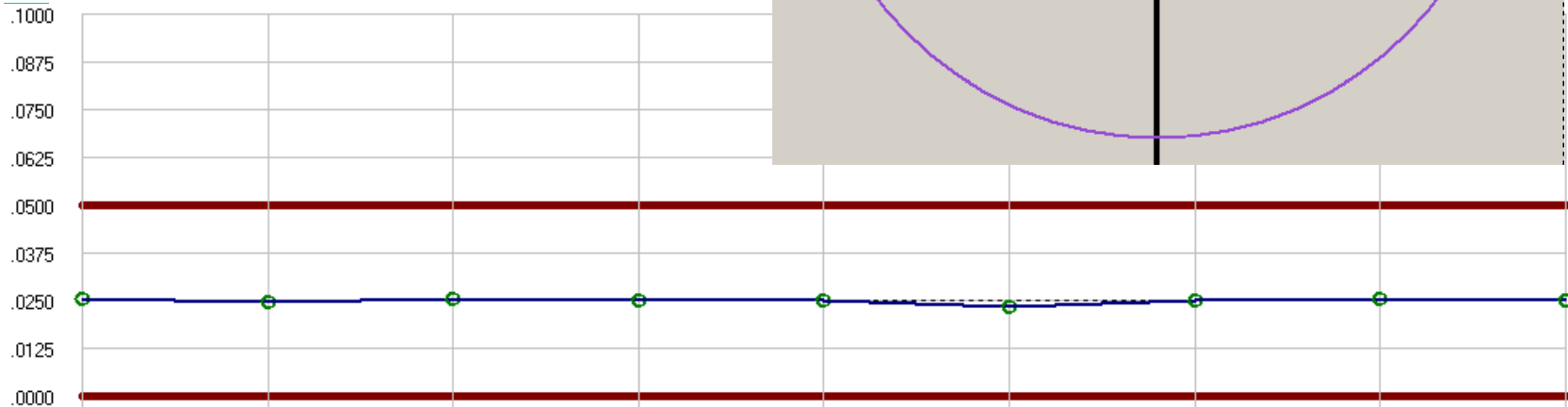
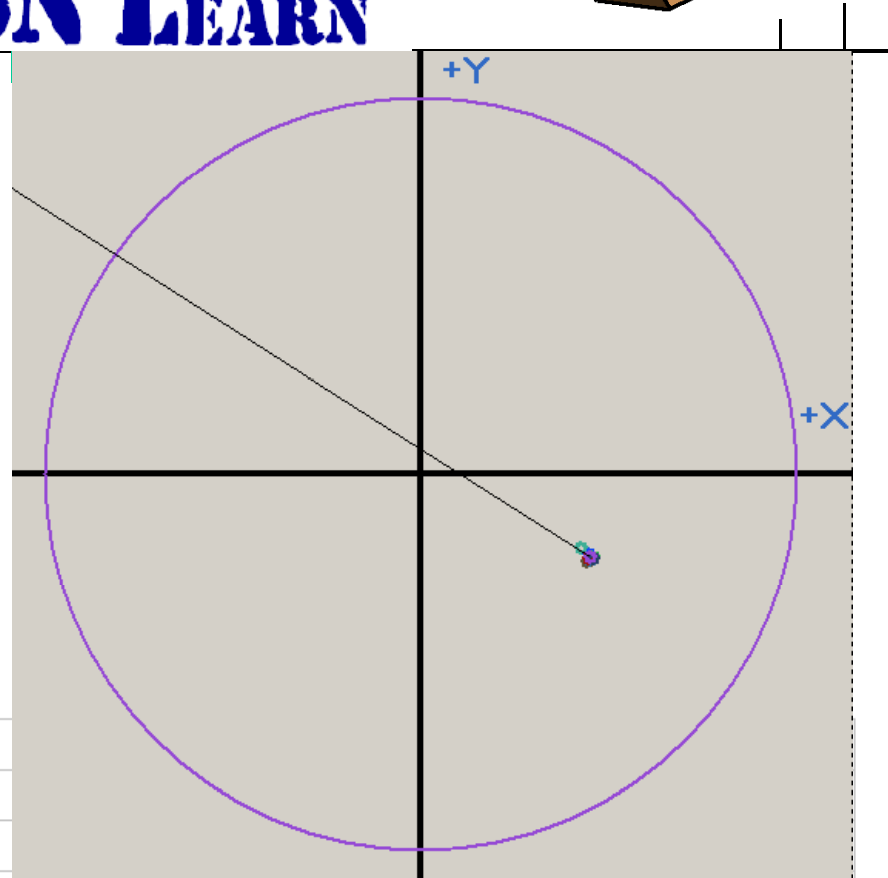

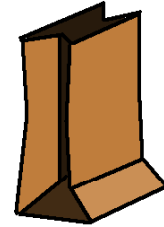
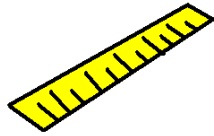

LUNCHEON LEARN

True Position Cylinder Bottom

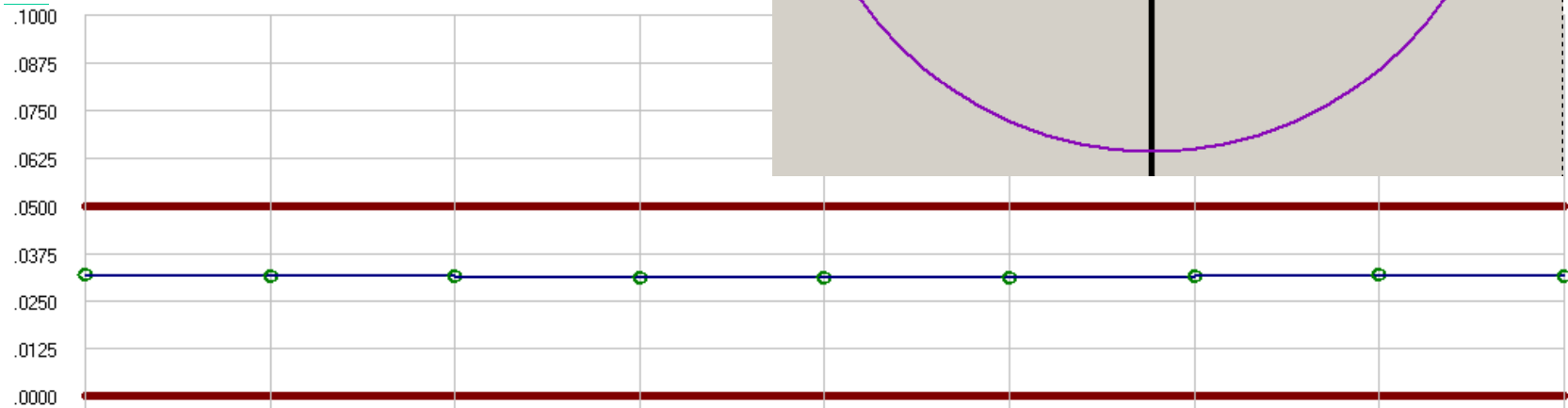
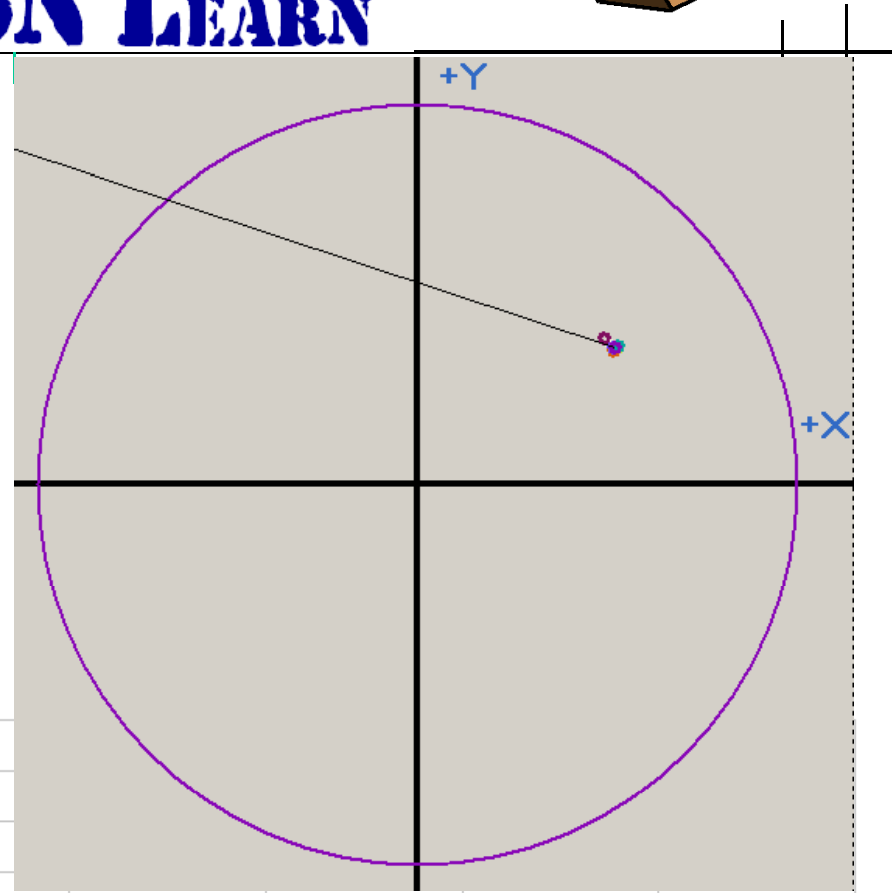

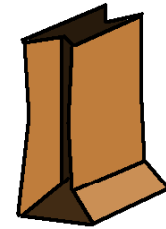
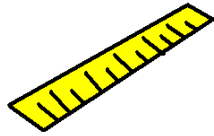

LUNCHEON LEARN

True Position Circle

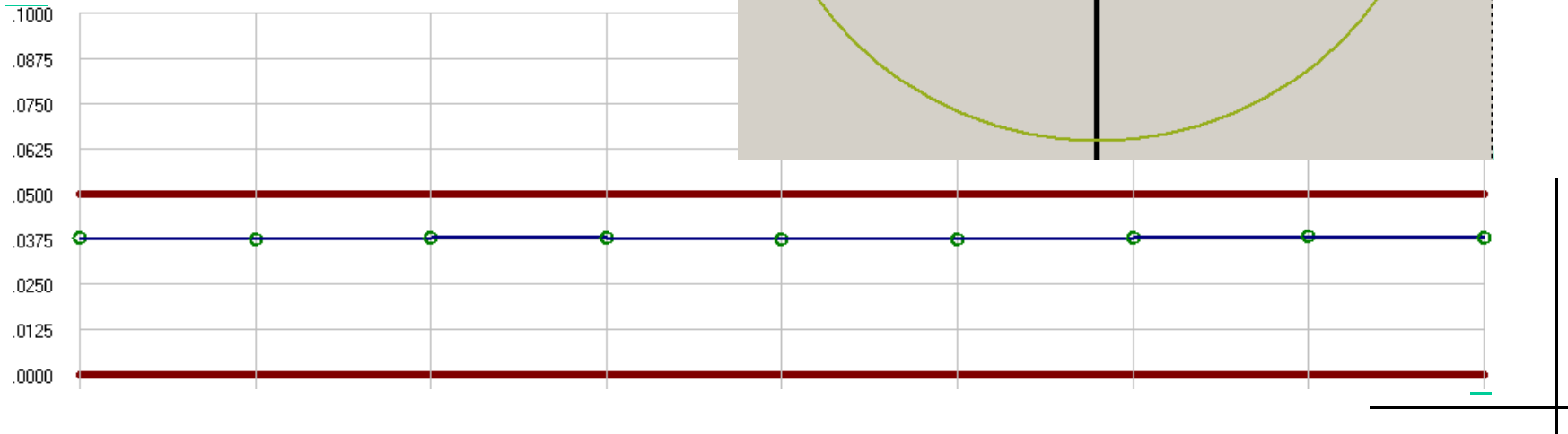
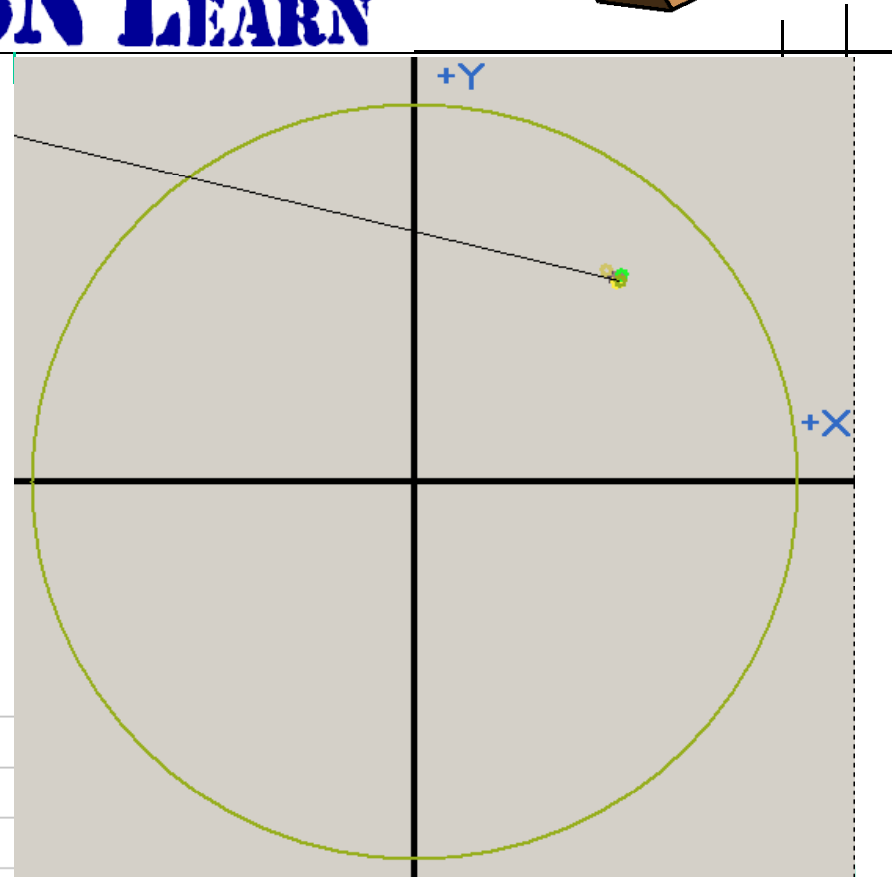

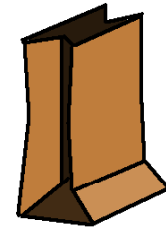
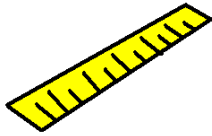

LUNCHEON LEARN

True Position Cylinder

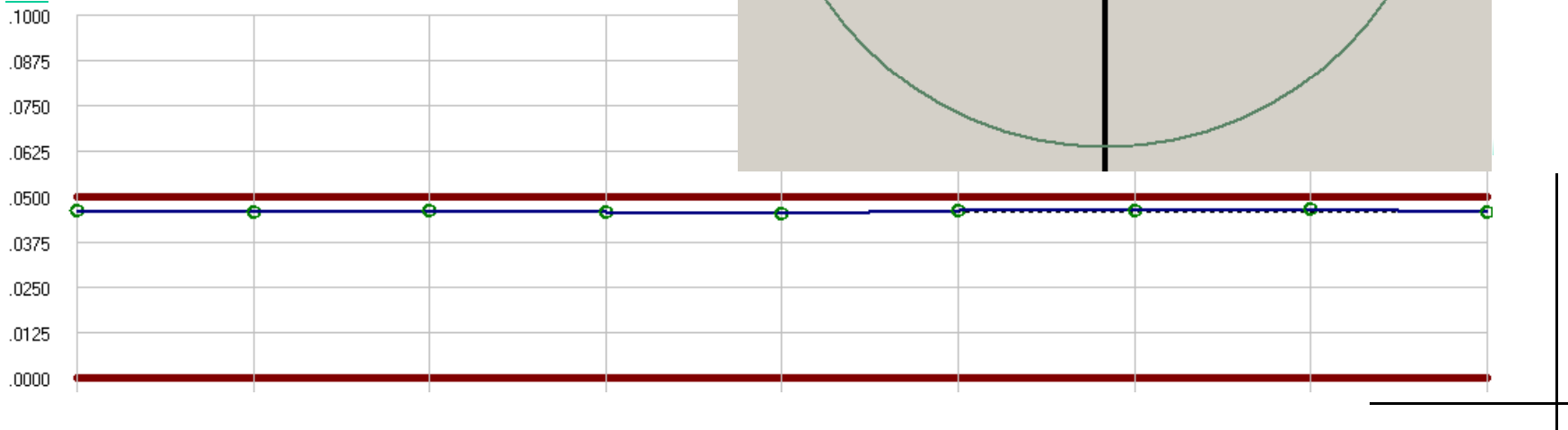
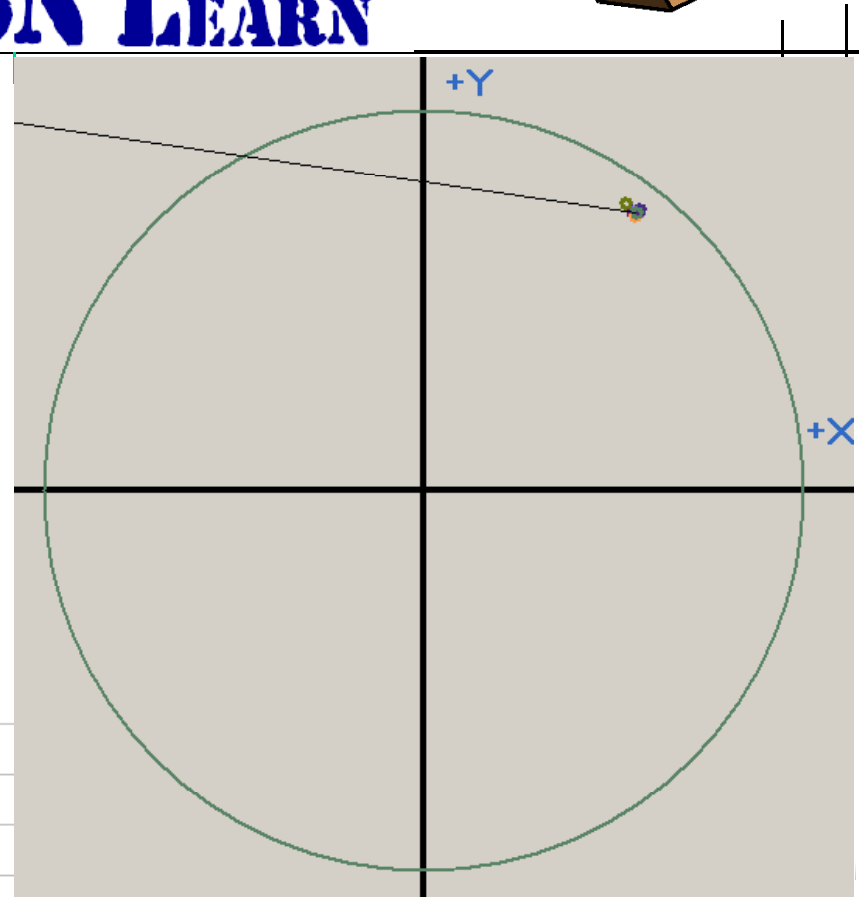

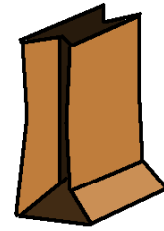
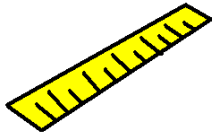

LUNCHEON LEARN

True Position Cylinder Top

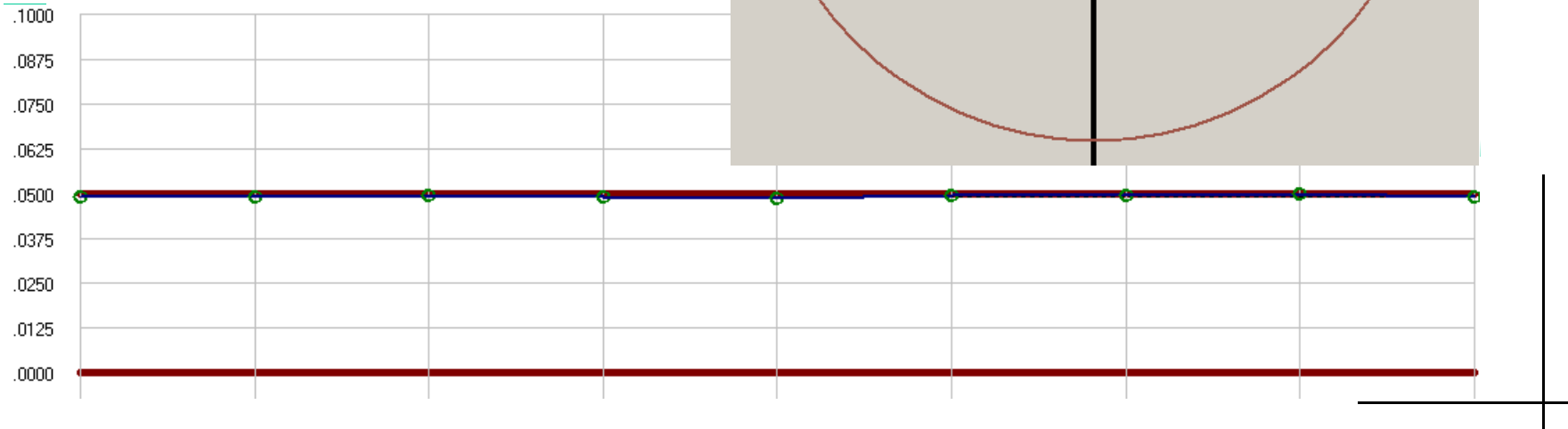
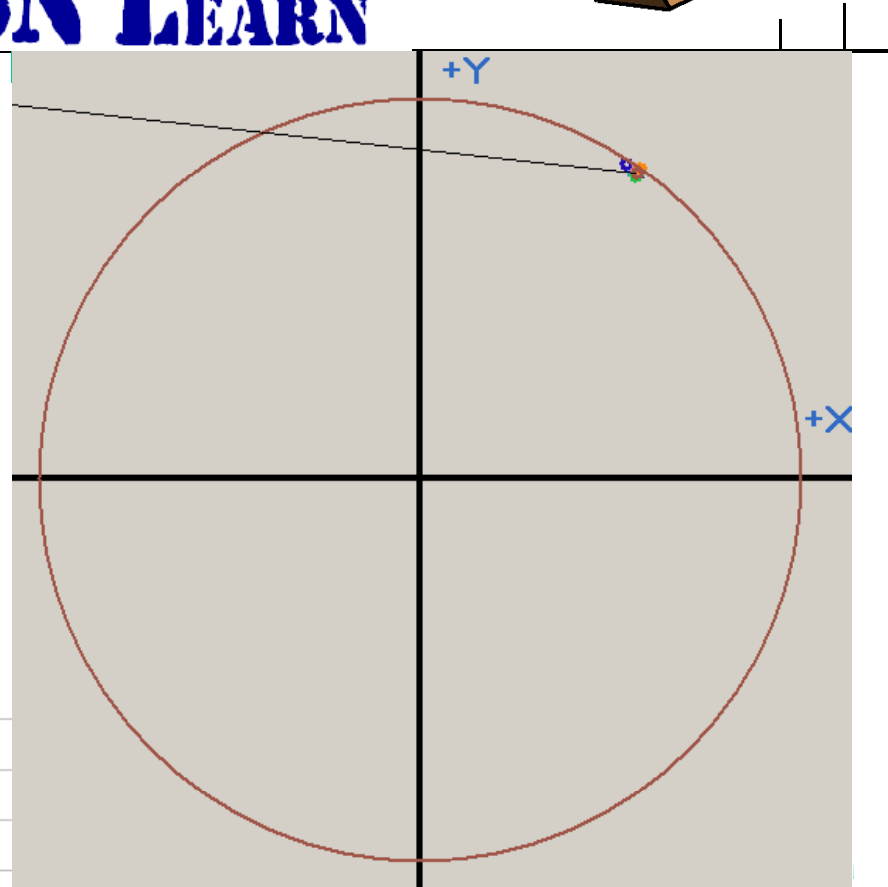

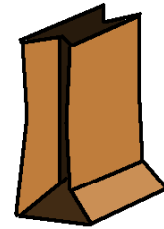
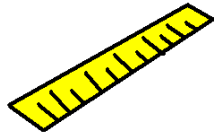

LUNCHEON LEARN

Good repeatability. Fixture is fine.

Same pattern of answers up the pin.

Why the different answer from first test?

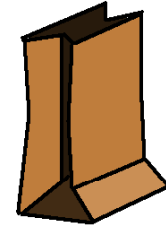
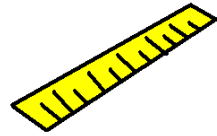

LUNCHEON LEARN

Run it 10 times and
screw/unscrew flexible
thread position gage to
prove gage repeatability...

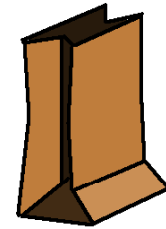
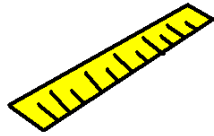

LUNCHEON LEARN

True Position Intersection

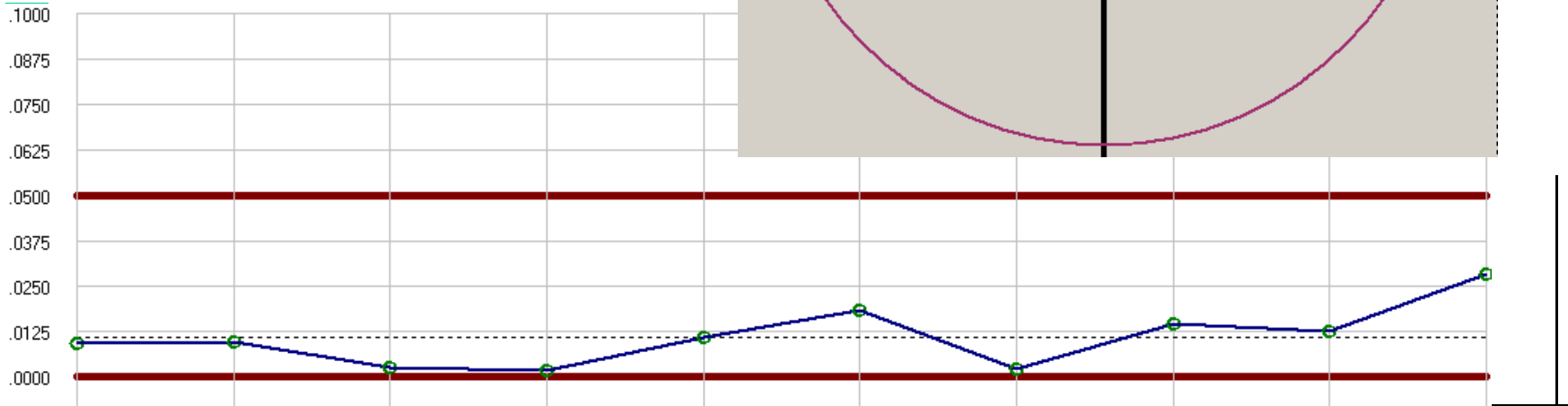
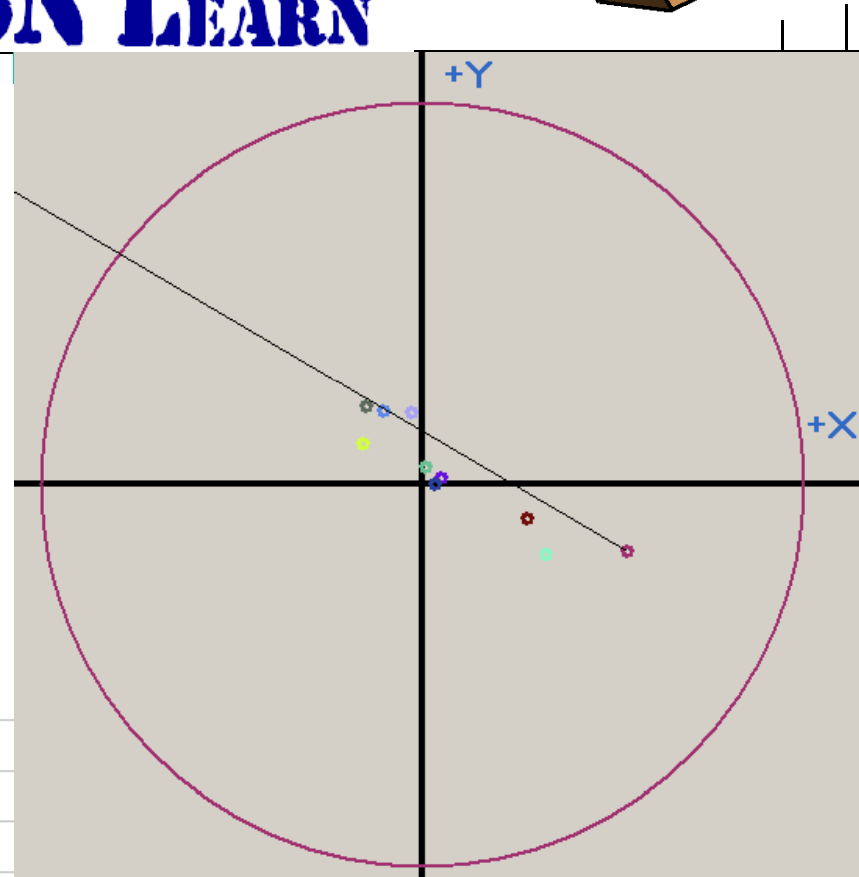

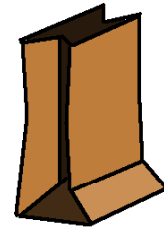
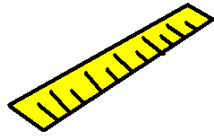

LUNCHEON LEARN

True Position Cylinder Bottom

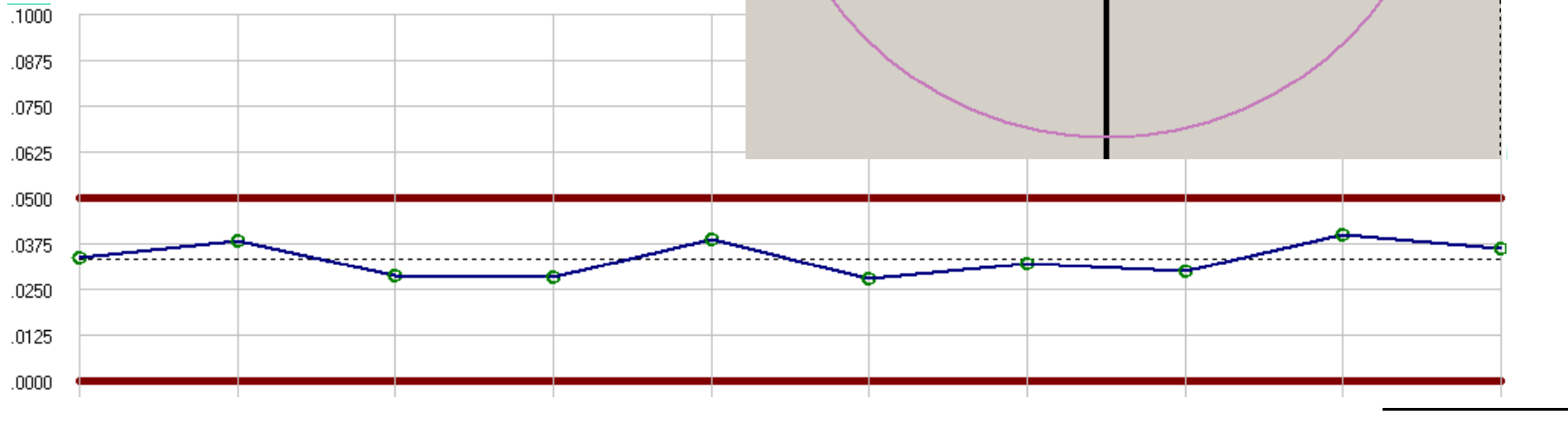
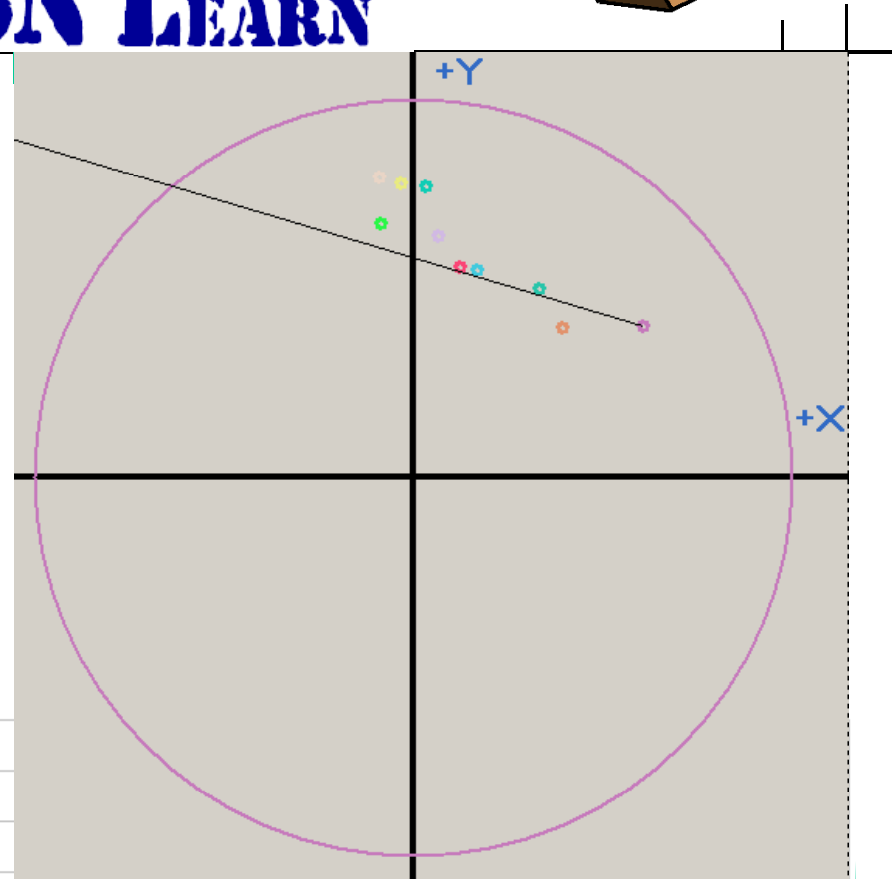

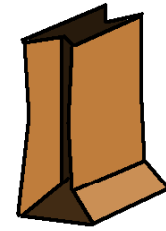
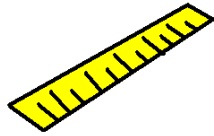

LUNCHEON LEARN

True Position Circle

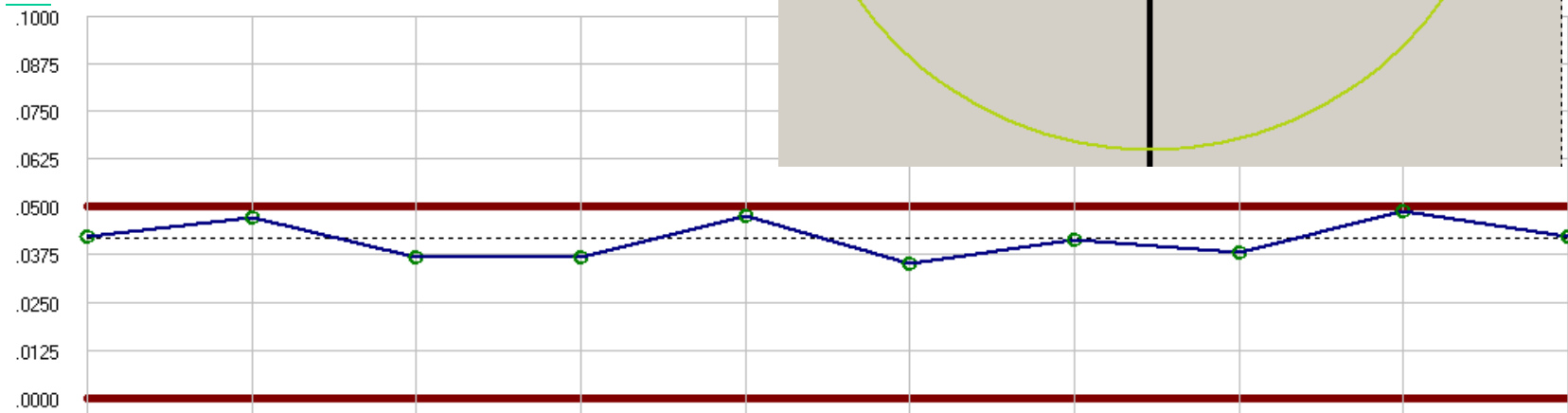
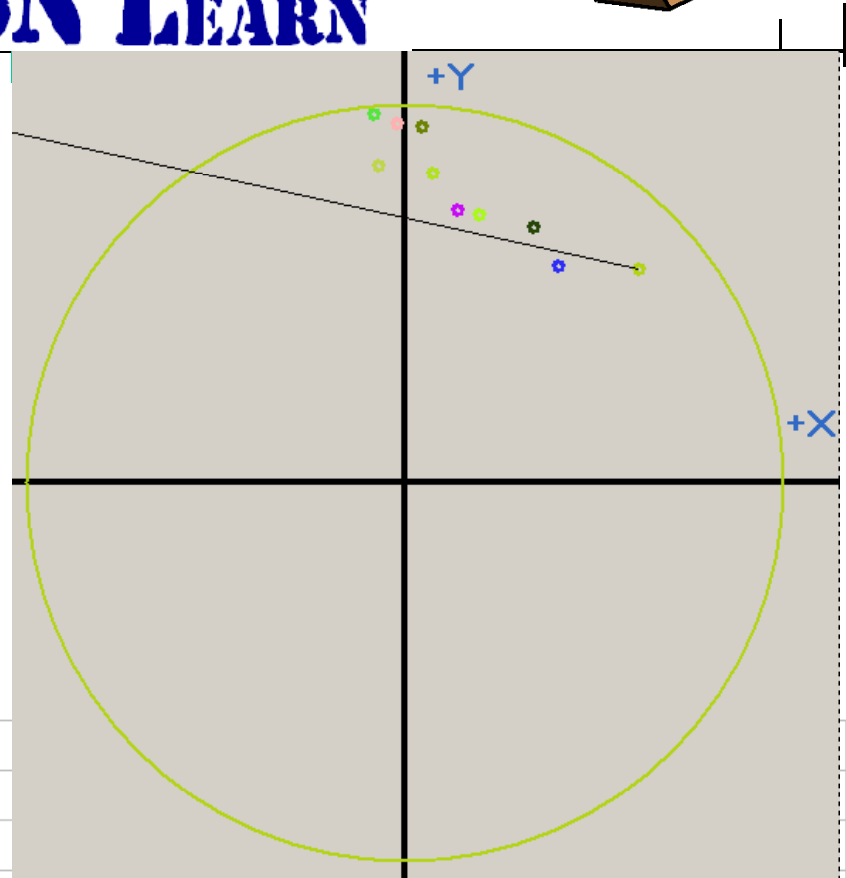

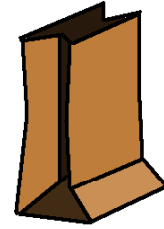
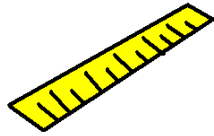

LUNCHEON LEARN

True Position Cylinder

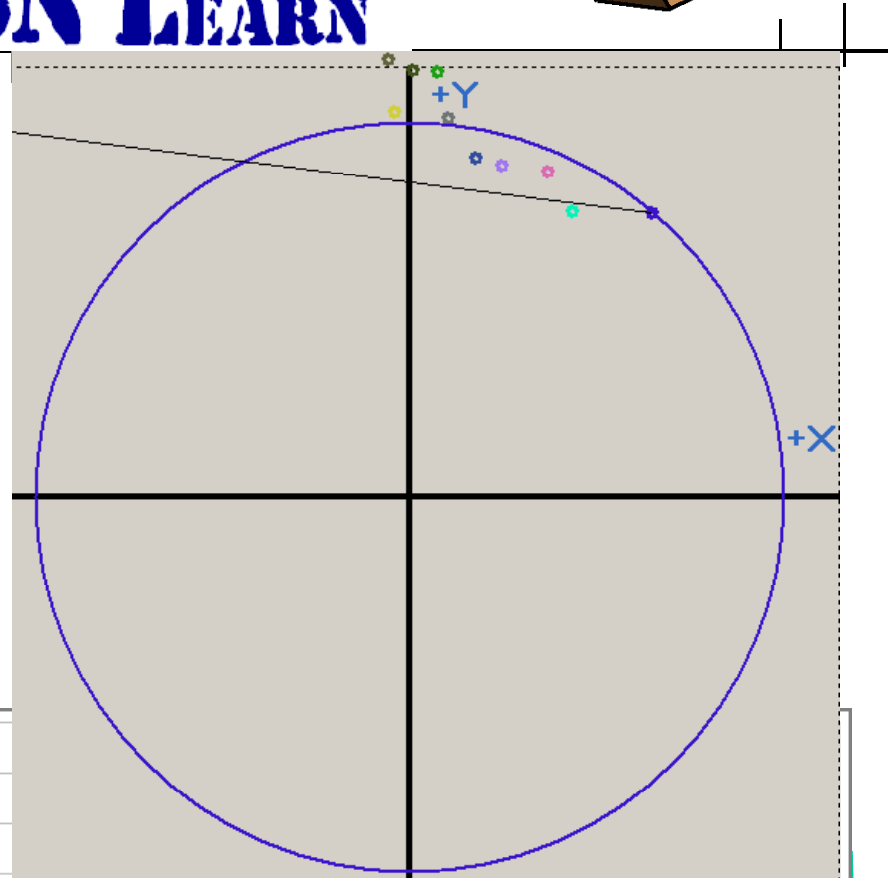

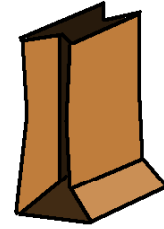
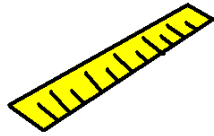

LUNCHEON LEARN

True Position Cylinder Top

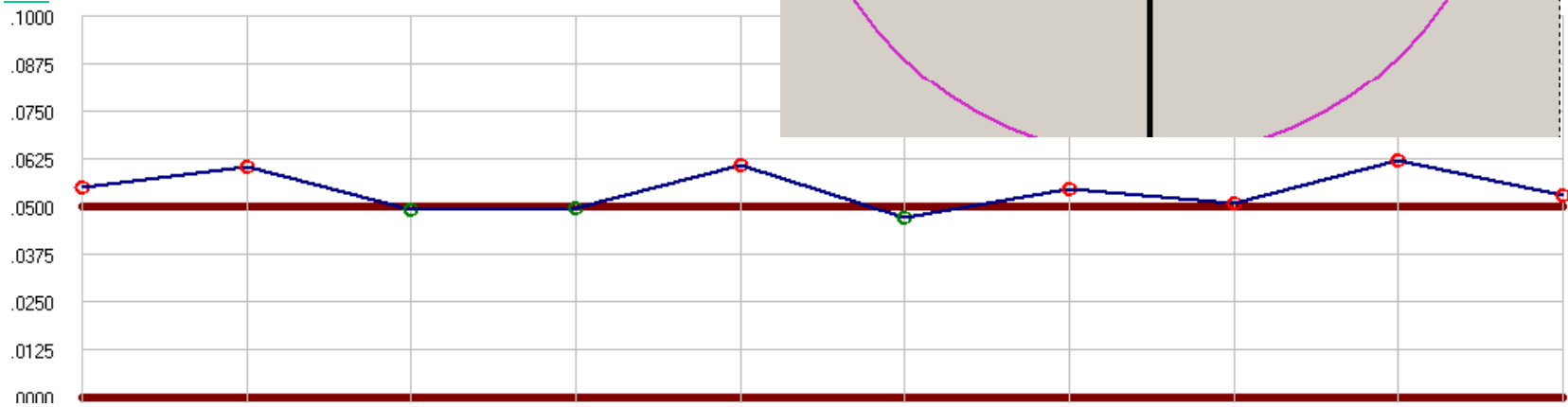
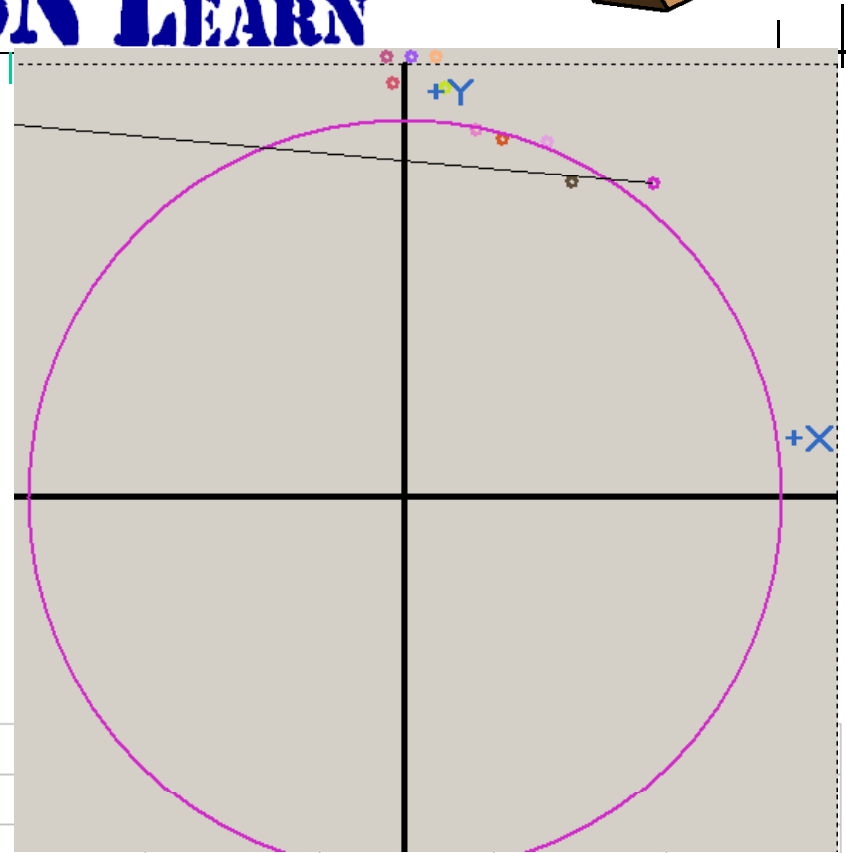

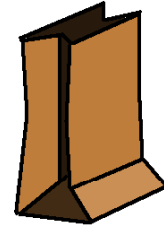
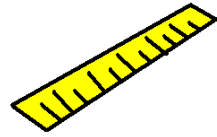

LUNCHEON LEARN

Bad repeatability.

What's Going On?

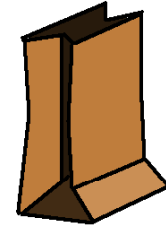
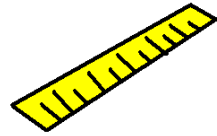

LUNCHEON LEARN

More testing!

Just looking at INTERSECTION
results

Remove/Replace Plug

(Duramax, 0.050mm tol)

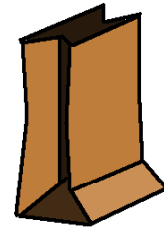
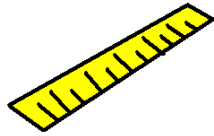

LUNCHEON LEARN

True Position Intersection

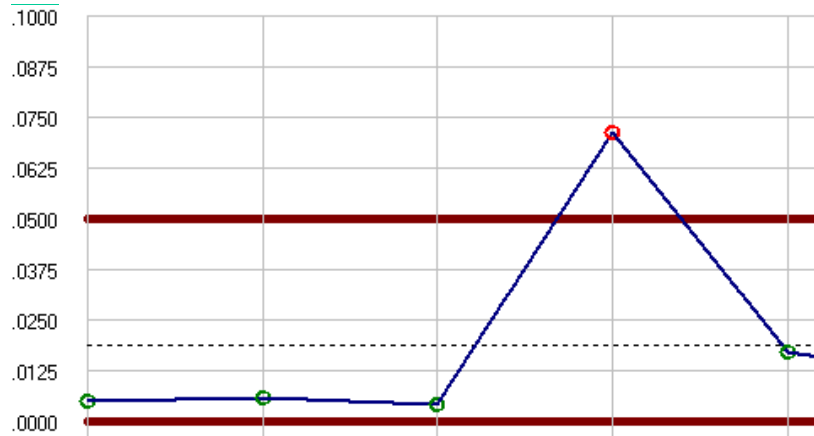
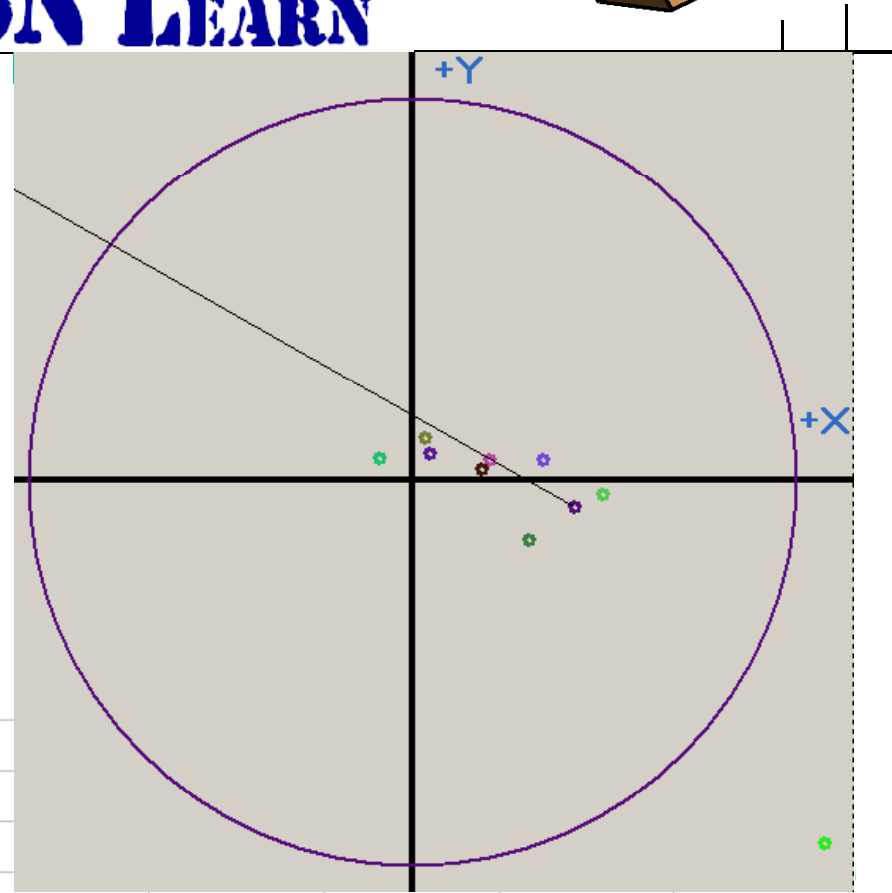

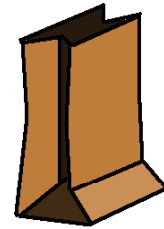
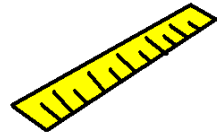

LUNCHEON LEARN

Same stuff.

Let's think about what's going on.

(I hate that...)

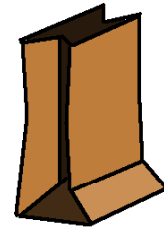
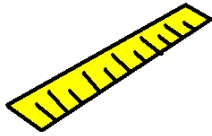

LUNCHEON LEARN

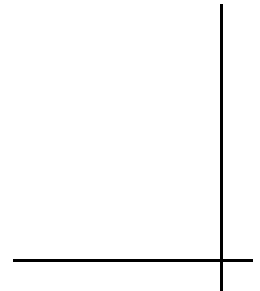
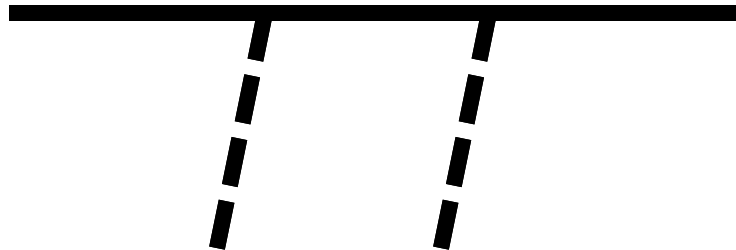
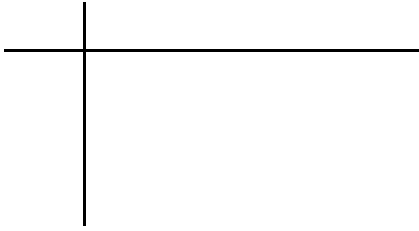

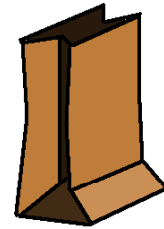
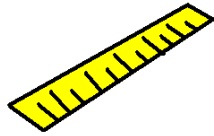

LUNCHEON LEARN

Tighten up a little...

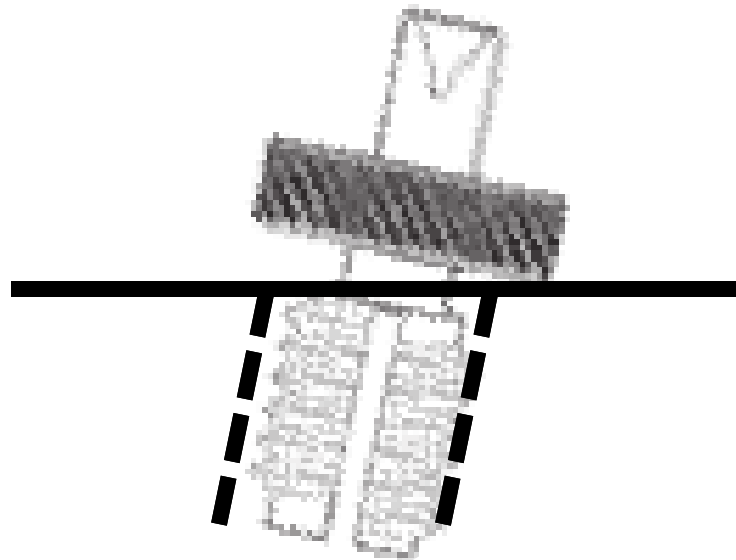

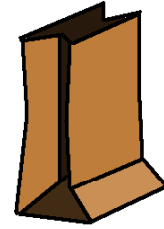
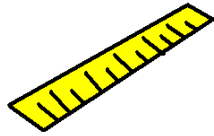

LUNCHEON LEARN



A little more...

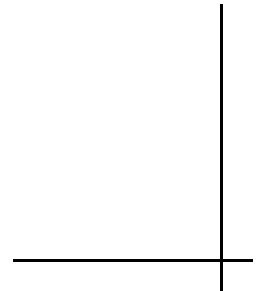
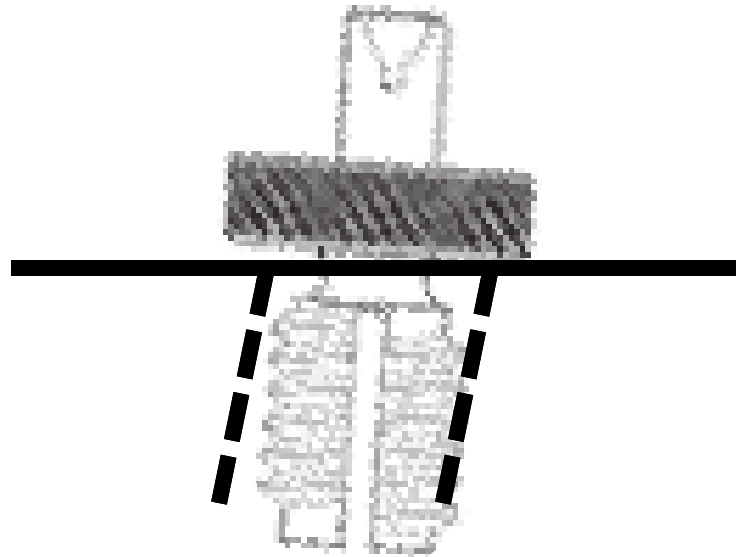

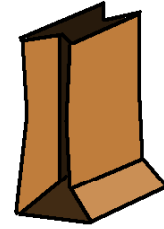
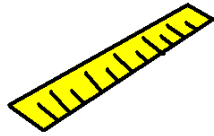

LUNCHEON LEARN

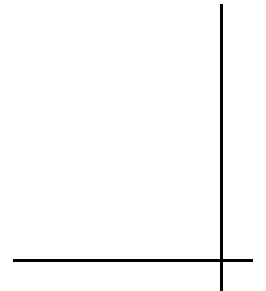
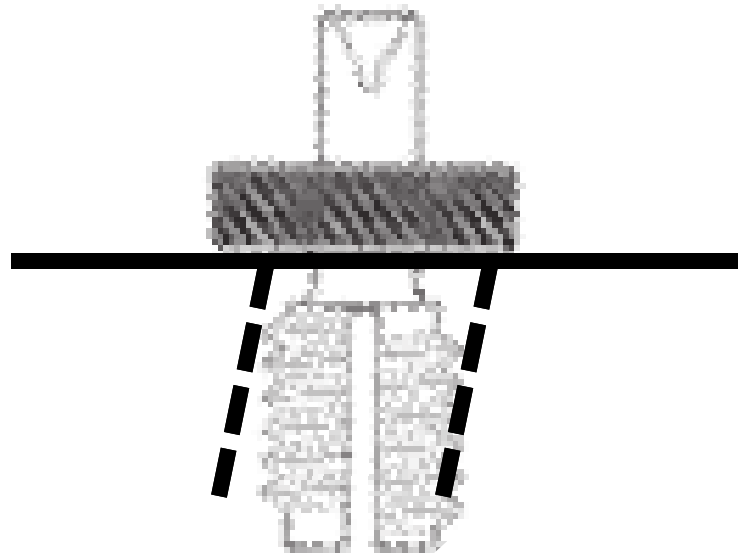
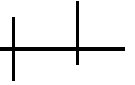
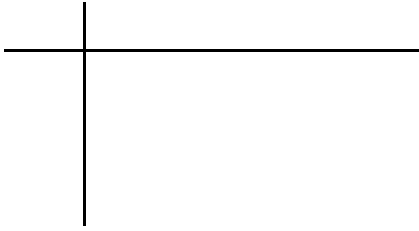

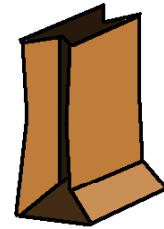
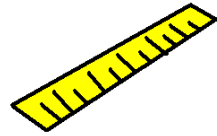

LUNCHEON LEARN

Ahhh...

So, based on how I tighten the
plug, the center will move.

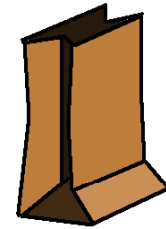
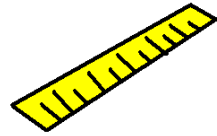

LUNCHEON LEARN

Just looking at INTERSECTION
results
Remove/Replace Plug, but Don't
tighten!

(Duramax, 0.050mm tol)

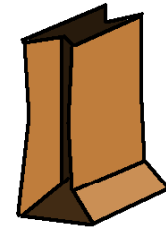
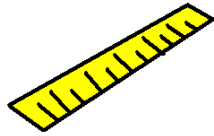

LUNCHEON LEARN

True Position Intersection

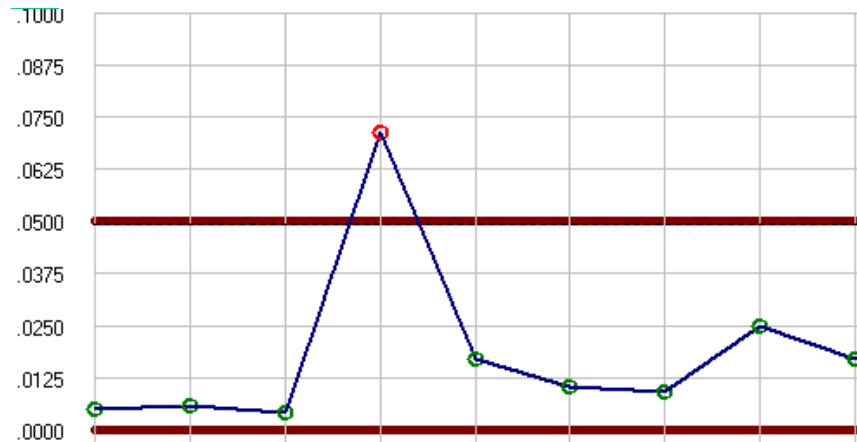
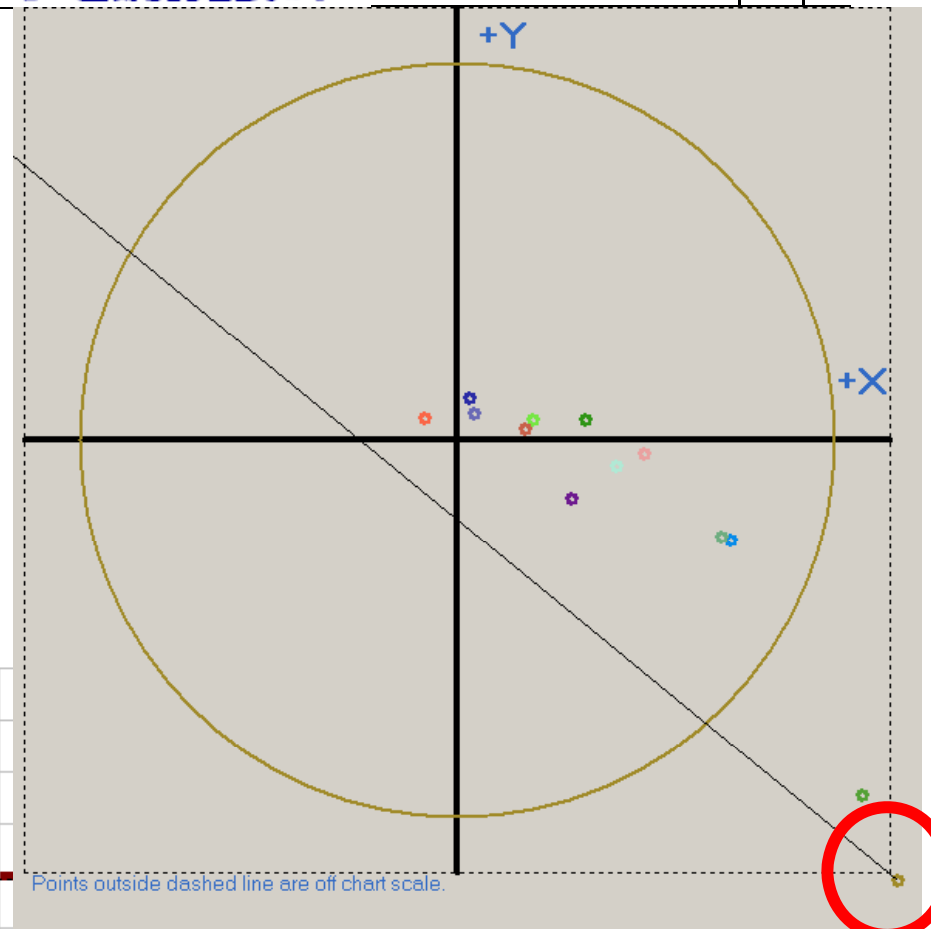

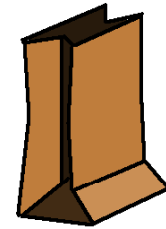
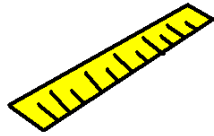

LUNCHEON LEARN

Wow!

Outside of 0.050mm tolerance!

Increase the tol to 0.200mm!

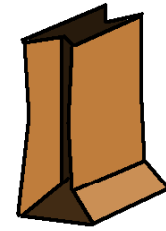
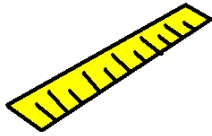

LUNCHEON LEARN

True Position Intersection

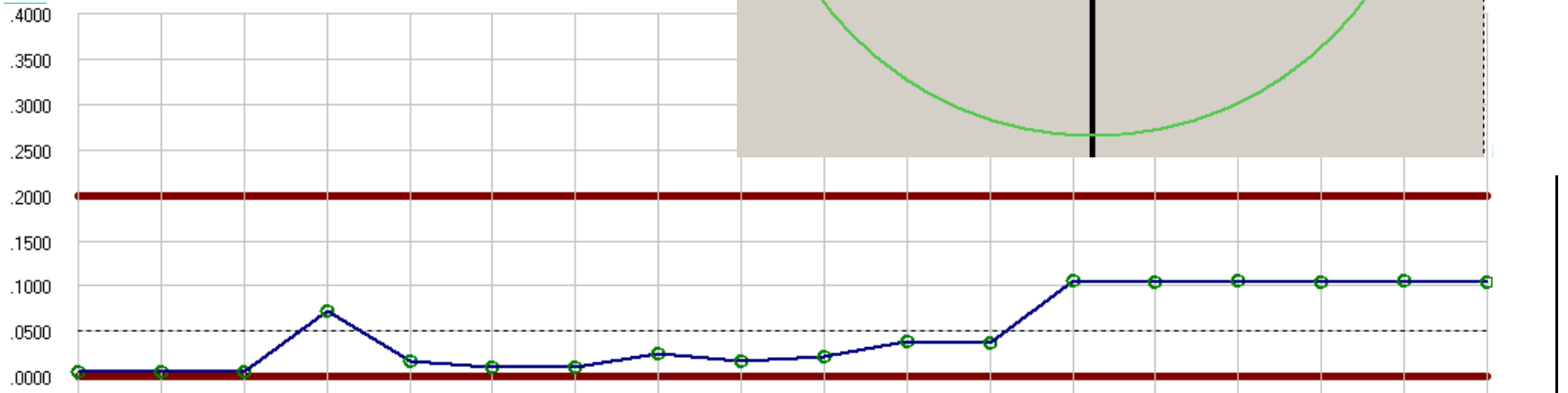
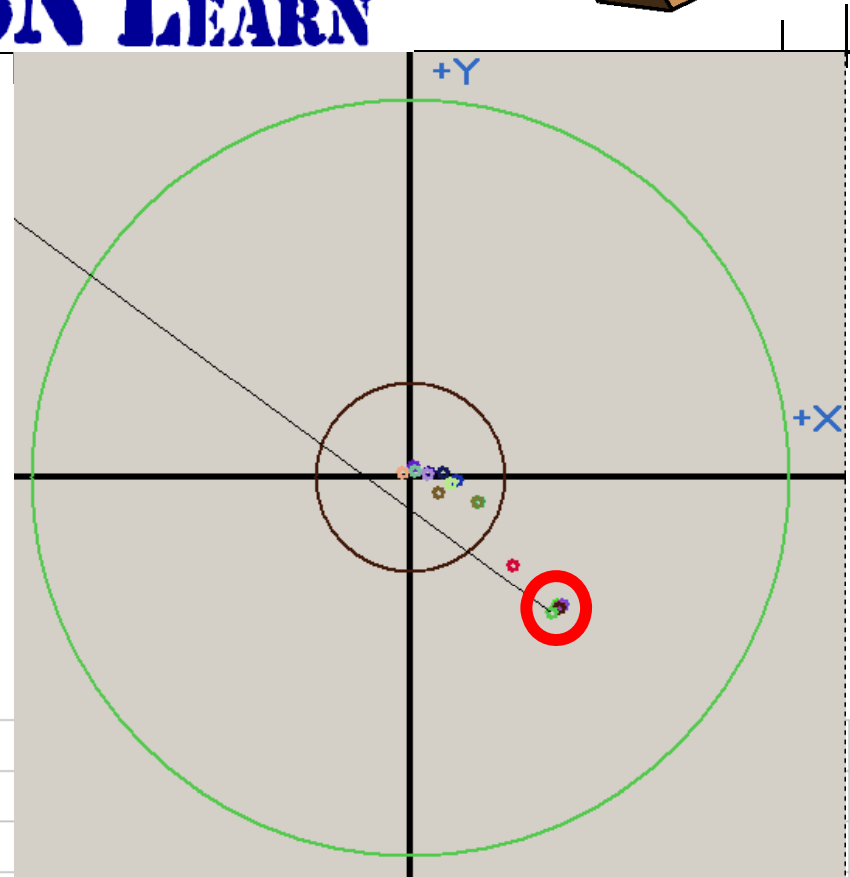

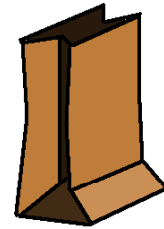
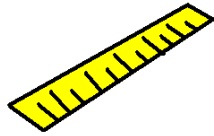

LUNCHEON LEARN

“Tight” flex plug

0.067mm repeatability

“loose” flex plug

0.002 (!) mm repeatability

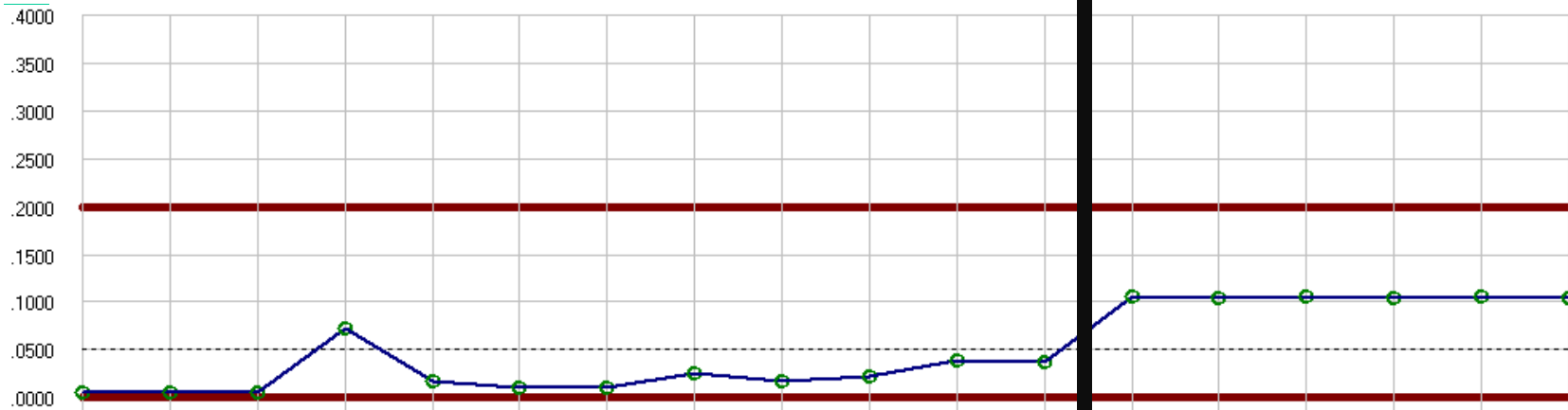

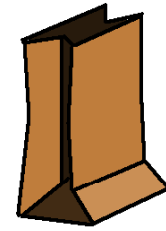
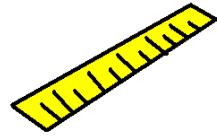

LUNCHEON LEARN

We are in BUSINESS!

Now, back to the original question:
How do you best measure a threaded
hole
(without the plug)?

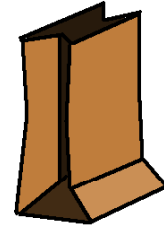
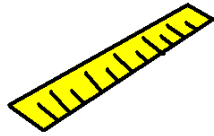

LUNCHEON LEARN

Calculating Gradient/Slope (aka lead or pitch)

$3/8 - 16 \text{ UNC} = 16 \text{ threads/inch}$

Gradient/Slope = $1/16$ or $0.0625''$ or 1.5875mm

$M10 \times 1.5 = 1.5 \text{ mm of lead per rev}$

Gradient/Slope = 1.5mm or $0.0591''$

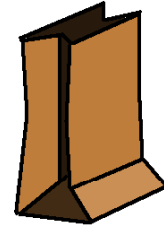
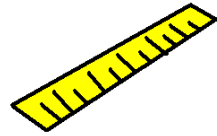

LUNCHEON LEARN

Measurement Strategy #1

A circle.

Concept: Who Cares, Close enough.

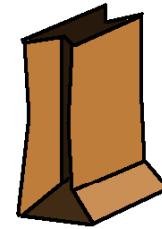
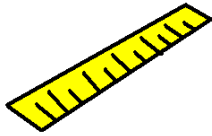

LUNCHEON LEARN

Circle Path

Circle

Presettings Calculate Datum Features

Speed Automatic Calculation 8.0000

Step Width 0.0506

Number of Points 500

Stylus #0 down

Single points

Basic options Special Settings

Start Angle

Angle Range

Tangential probing (Default) Yes

Start height

OK Reset

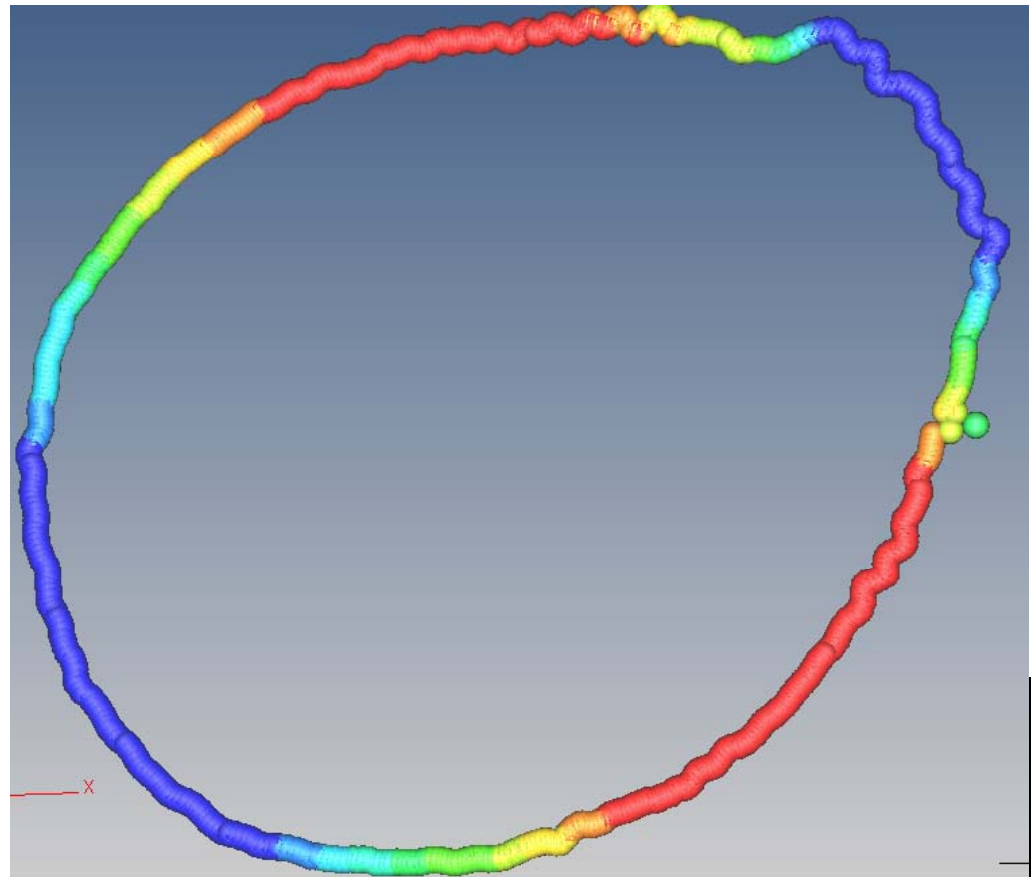

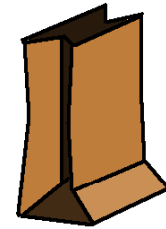
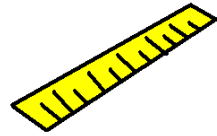

LUNCHEON LEARN

Measurement Strategy #2

Symmetry between Two Circles, $\frac{1}{2}$
Pitch apart

Concept: Average of shifted circle
centers will be real center

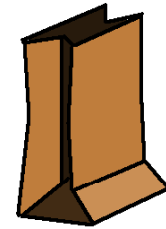
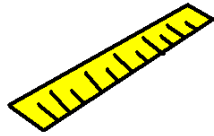

LUNCHEON LEARN

Symmetry

Symmetry1 Comment

Alignment [Base Alignment]

Feature 1
Circle

Feature 2
Circle1

Result Selection
1 2

Tolerance For:	Nominal	Actual
<input type="checkbox"/> X	171.4250	171.3922
<input type="checkbox"/> Y	127.0000	126.9917
<input type="checkbox"/> Z	-3.4861	-3.0832

OK Reset

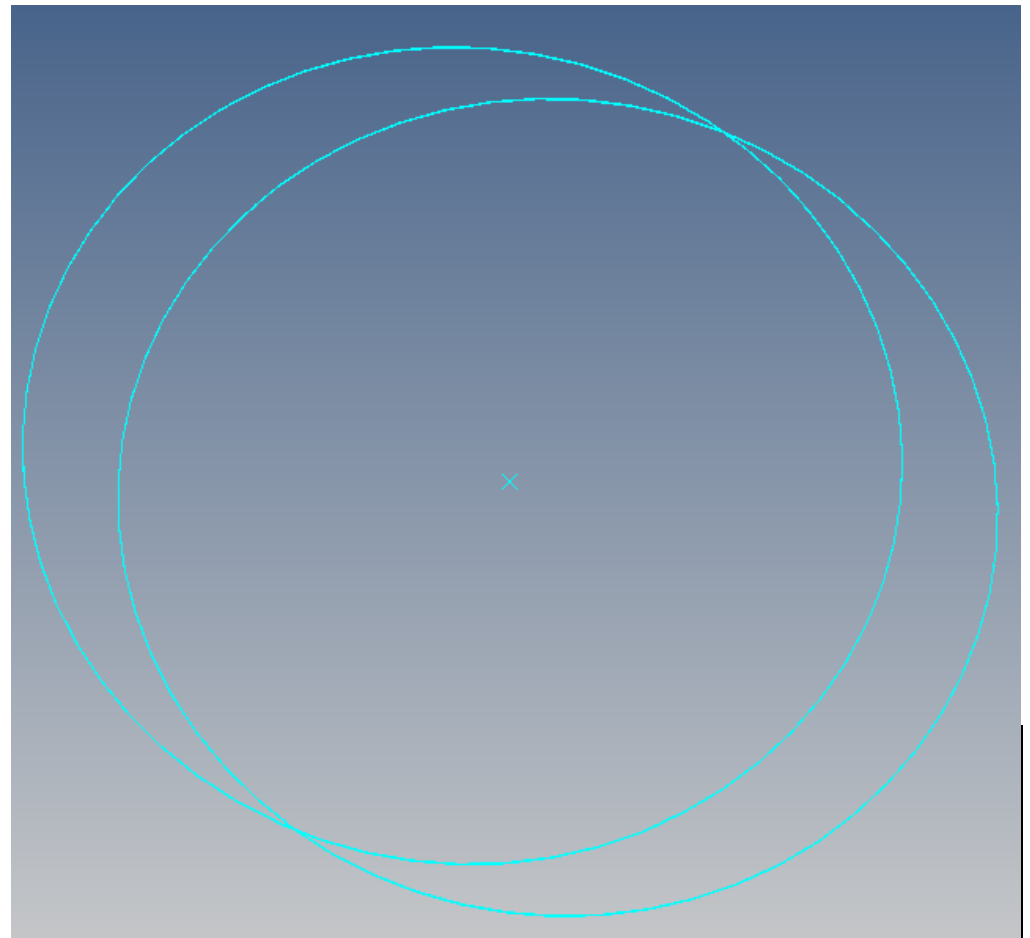

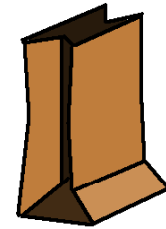
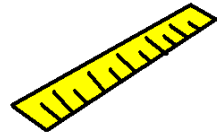

LUNCHEON LEARN

Measurement Strategy #3

One circle, Two Circle paths, $\frac{1}{2}$ Pitch
apart

Concept: Same theory as Symmetry,
but no construction step

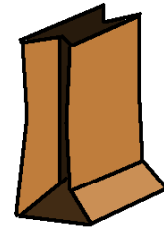
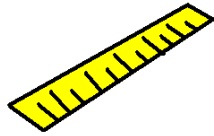

LUNCHEON LEARN

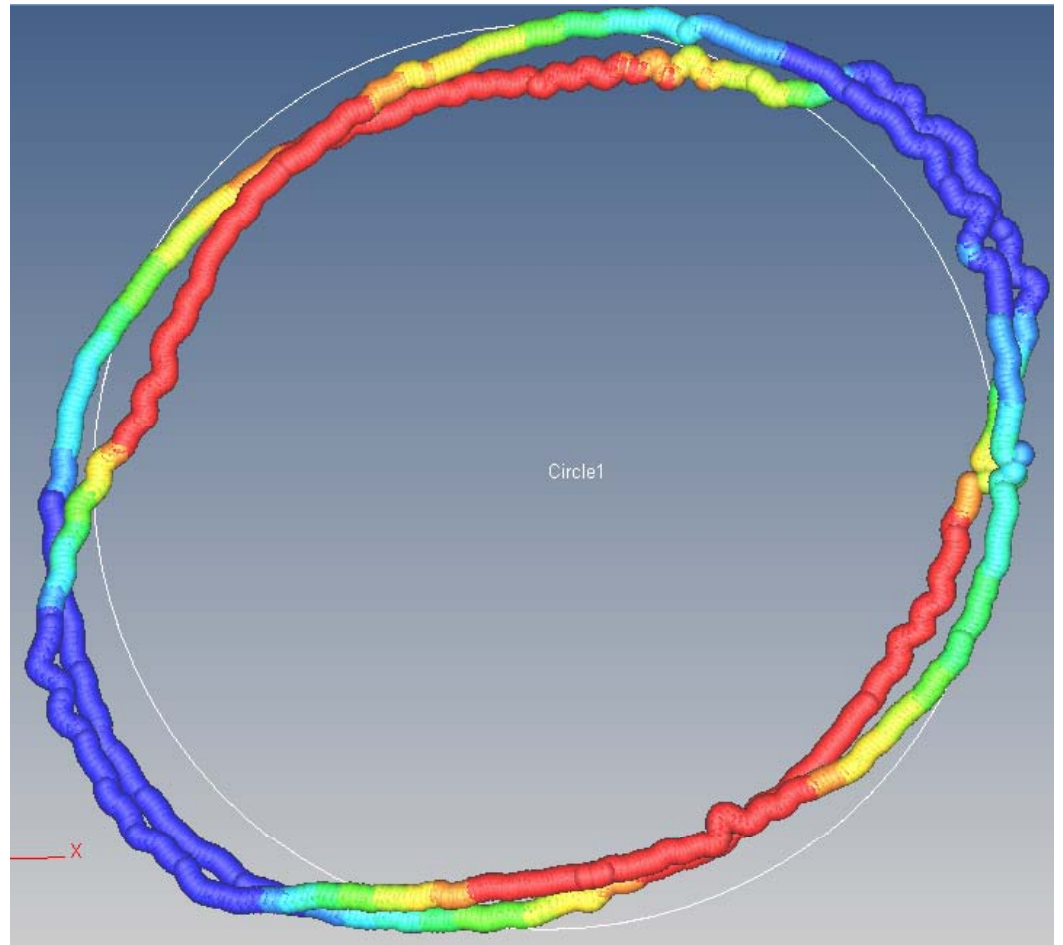
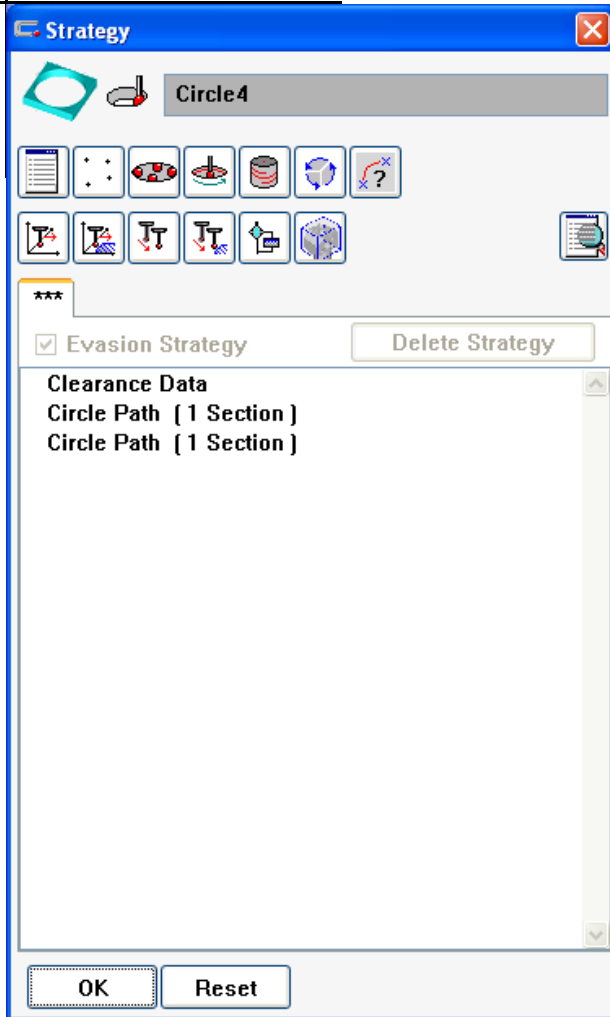

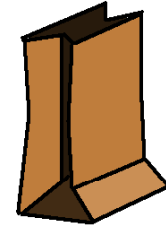
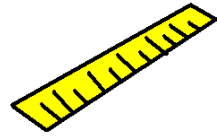

LUNCHEON LEARN

Measurement Strategy #4

Calypso's Circle Macro

Concept: The Thread routine in the software **MUST** be good.

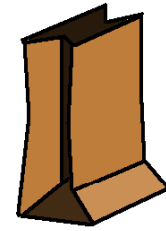
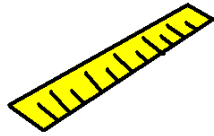

LUNCHEON LEARN

Strategy

Circle Macro

Number of Points: 4

Thread lead: 1.5875 mm

Direction of thread:

- Right-hand thread
- Left-hand thread

OK Cancel

OK Reset

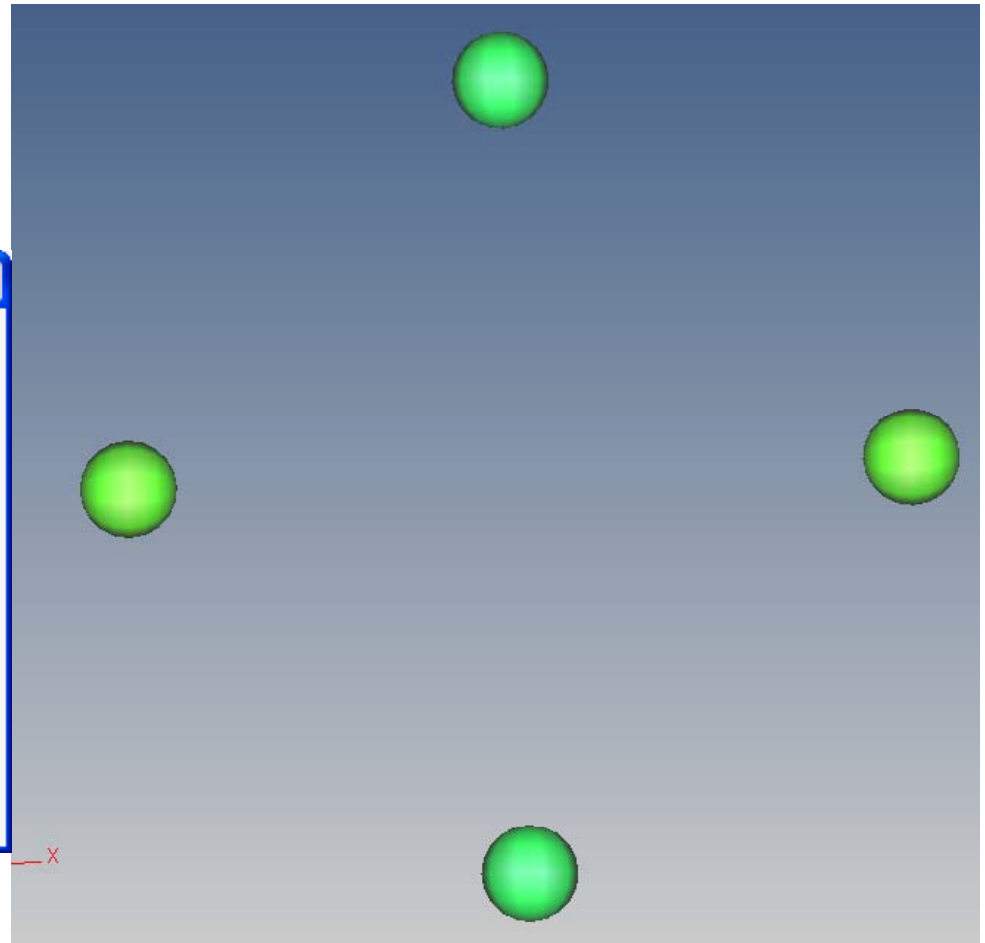

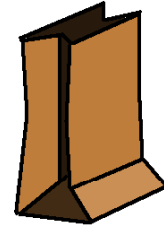
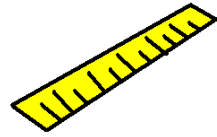

LUNCHEON LEARN

Measurement Strategy #5

circle with helix path on pitch

Concept: Center will be good, Who cares where it is measured, as long as it follows thread pitch.

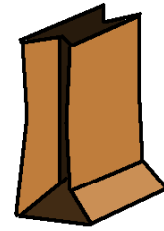
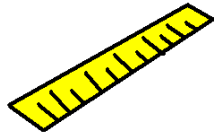

LUNCHEON LEARN

Helix [Close]

Circle Helix

Presettings Calculate Datum Features

Speed: 8.0000

Step Width: 0.0507

Number of Points: 500

Stylus: #0 down

Single points:

Basic options | Special Settings

Start height: 0.0000

Target height: 1.5875

Number of rotations: 1.00

Gradient/Slope: 1.5875

Number of circles: 0

Start Angle: $\uparrow +z$ 0.0000

Rotation direction: Right

OK Reset

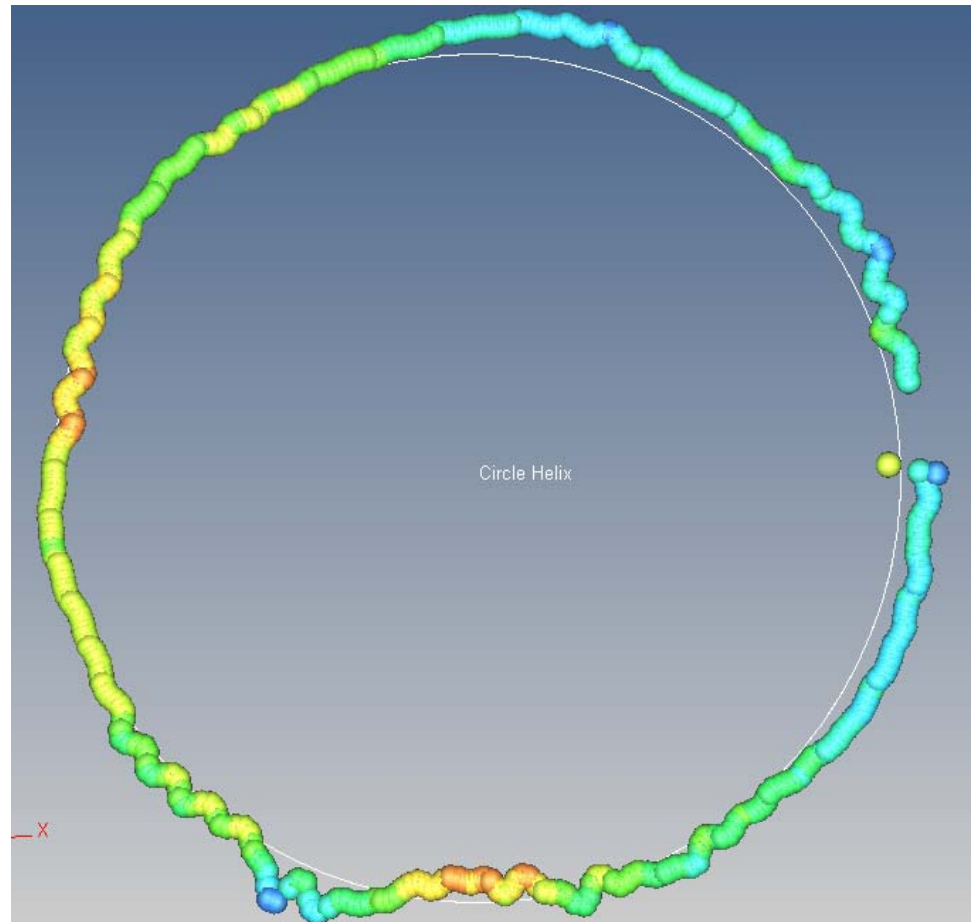

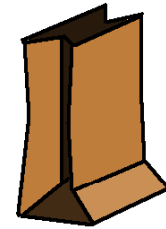
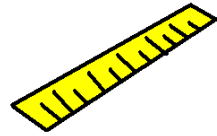

LUNCHEON LEARN

Measurement Strategy #6

Cylinder with 3 pitch helix revolutions

Concept: Measuring a cylinder to get an axis is better than just a circle.

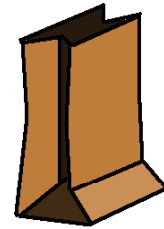
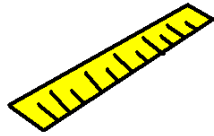

LUNCHEON LEARN

Helix

Cylinder 3 Helix

Presettings Calculate Datum Features

Speed 8.0000

Step Width 0.0505

Number of Points 1504

Stylus #0 down

Single points

Basic options Special settings

Start height 8.0000

Target height 7.7625

Number of rotations 3.00

Gradient/Slope 1.5875

Number of circles 0

Start Angle \uparrow +z 0.0000

Rotation direction Right

OK Reset

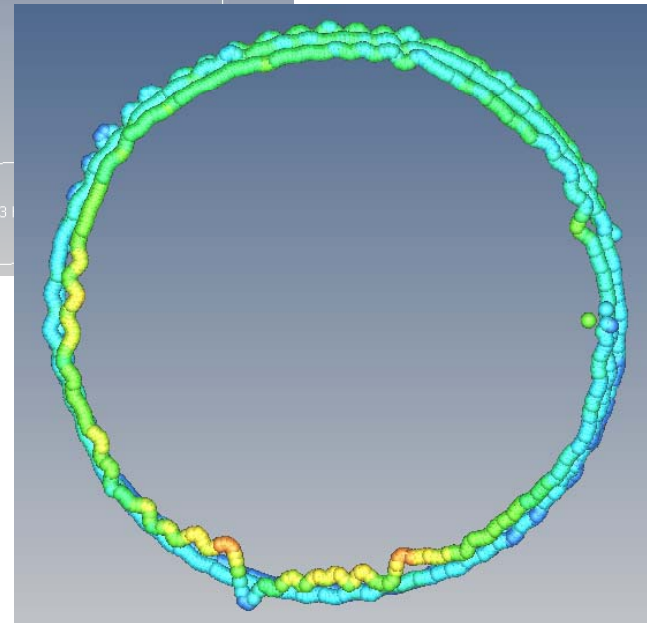
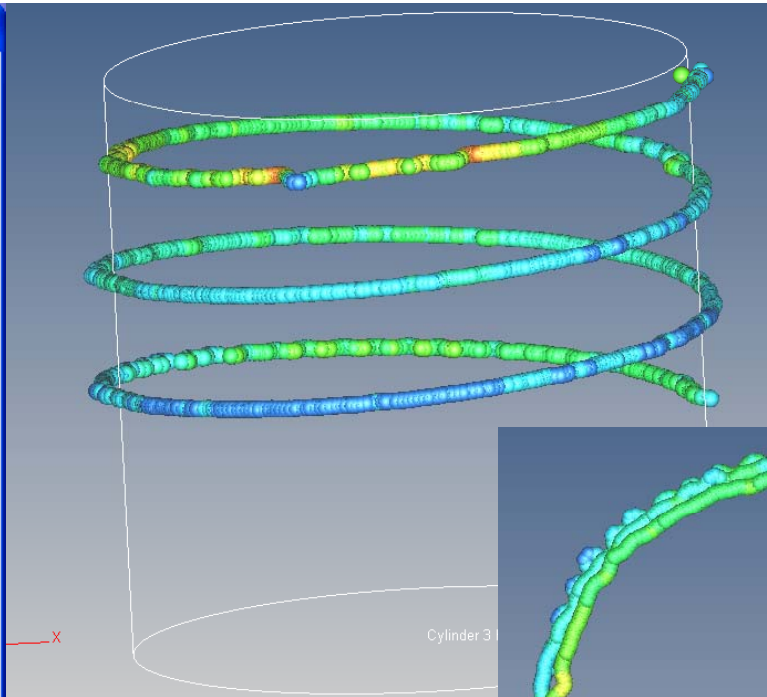

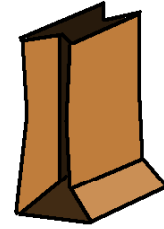
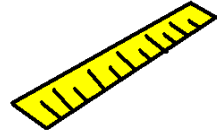

LUNCHEON LEARN

Measurement Strategy #7

Cylinder with 5 pitch helix revolutions

Concept: 5 revs must be better than
3!

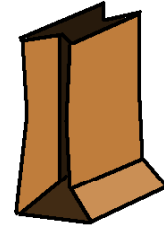
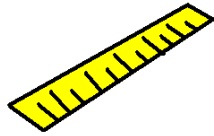

LUNCHEON LEARN

Helix

Cylinder 5 Helix

Presettings Calculate Datum Features

Speed 8.0000

Step Width 0.0507

Number of Points 2498

Stylus #0 down

Single points

Basic options Special Settings

Start height 0.0000

Target height 7.9375

Number of rotations 5.00

Gradient/Slope 1.5875

Number of circles 0

Start Angle 0.0000

Rotation direction Right

OK Reset

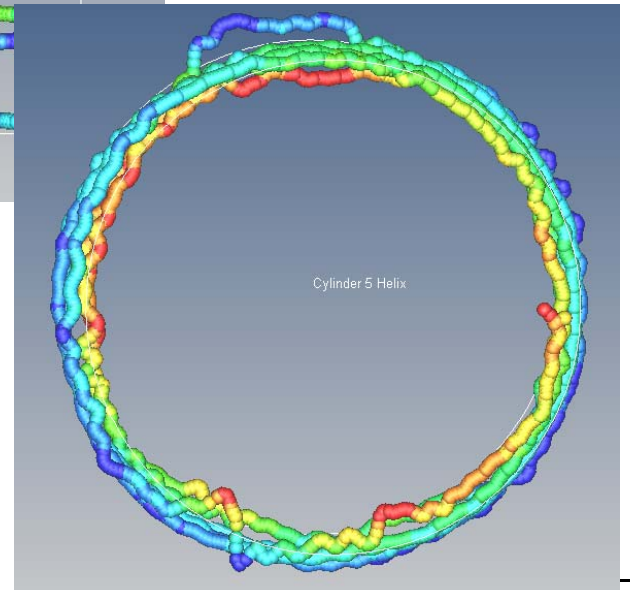
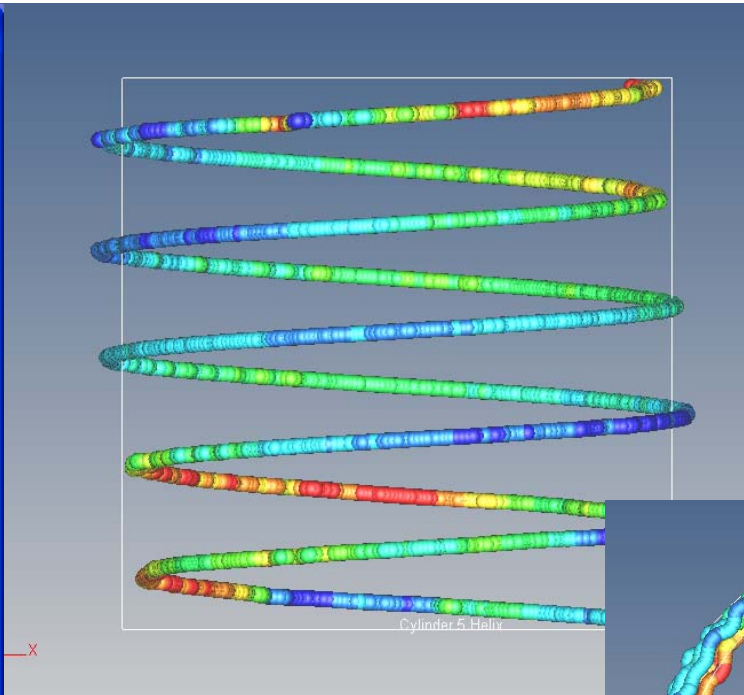

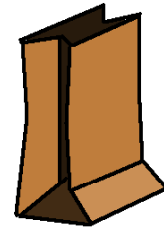
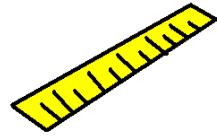

LUNCHEON LEARN

Measurement Strategy #8

Cylinder with double-pitch helix.

Concept: scan a lot on the thread – it will average out to the true center.

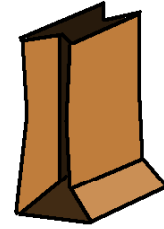
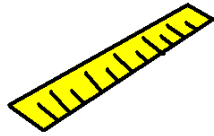

LUNCHEON LEARN

Helix

Cylinder DoublePitch

Presettings Calculate Datum Features

Speed 8.0000

Step Width 0.0507

Number of Points 4987

Stylus #0 down

Single points

Basic options Special Settings

Start height 0.0000

Target height 7.9375

Number of rotations 10.00

Gradient/Slope 0.7937

Number of circles 0

Start Angle $\uparrow +z$ 0.0000

Rotation direction Right

OK Reset

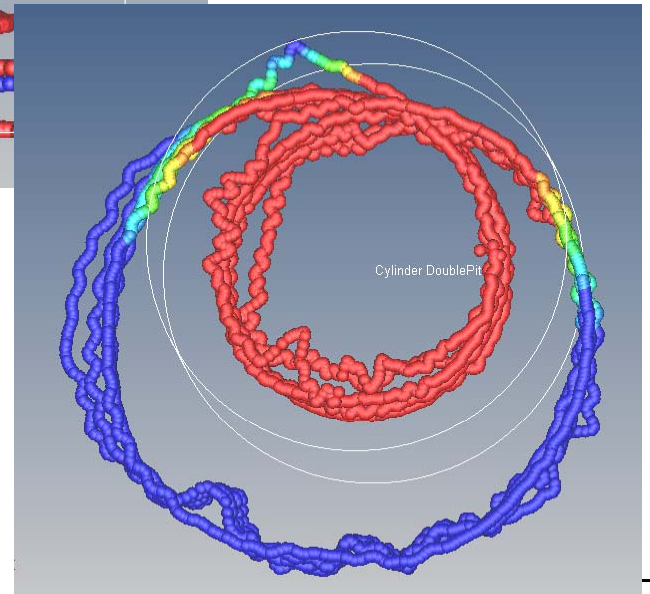
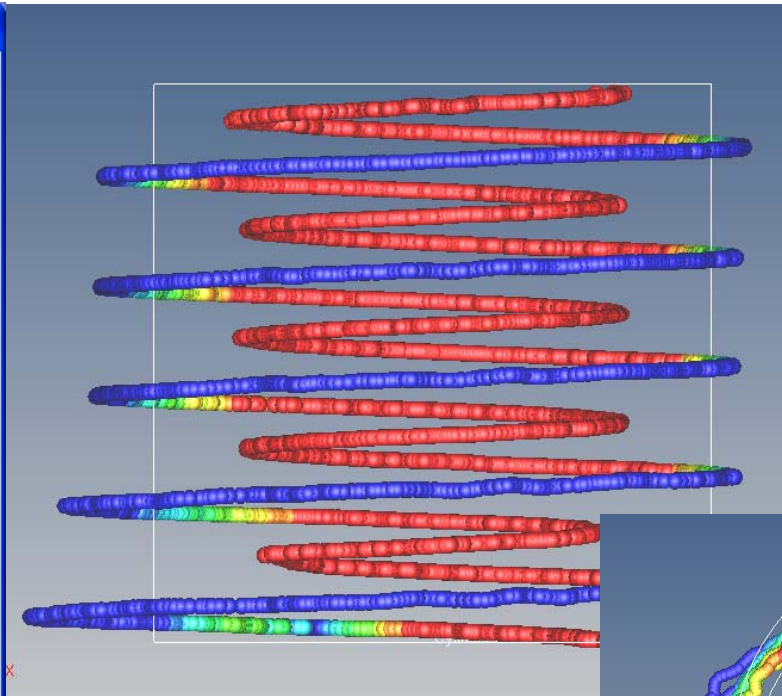

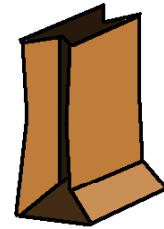
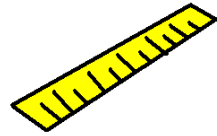

LUNCHEON LEARN

Measurement Strategy #9

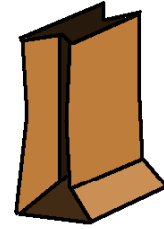
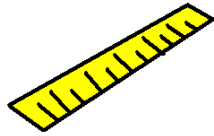

Cylinder with Linear Paths.

Concept: scan a lot on the thread – it will average out to the true center.



LUNCHEON LEARN

Linear paths ✕

  **Cylinder Linear**

Presettings **Calculate** **Datum Features**

Expected Tolerance

Speed

Step Width

Number of Points per Line

Stylus

Single points

Basic options **Special Settings**

Start height

Target height

No. of Lines

Start Angle

Angle Range 

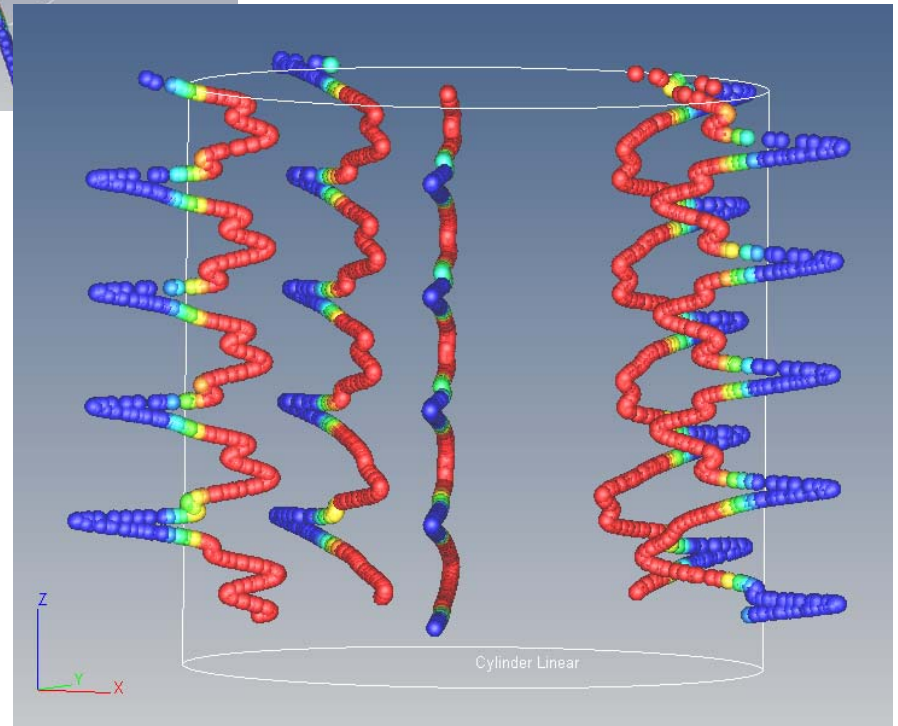
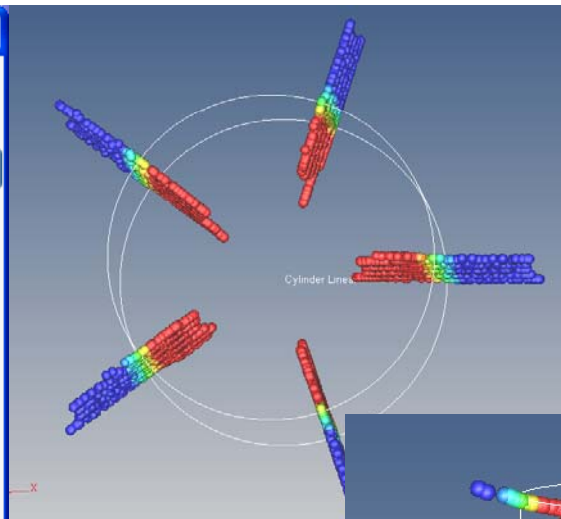

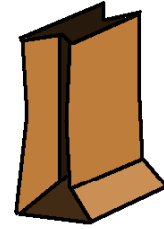
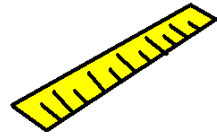

LUNCHEON LEARN

Measurement Strategy #10

Cylinder with reverse Helix.

Concept: scan a lot on the thread – it will average out to the true center.

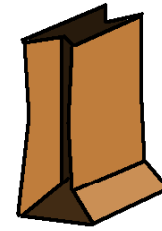
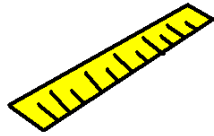

LUNCHEON LEARN

Helix [Close]

Cylinder Rev Helix

Presettings Calculate Datum Features

Speed: 8.0000

Step Width: 0.0506

Number of Points: 2497

Stylus: #0 down

Single points:

Basic options | Special Settings

Start height: 4.0000

Target height: 7.9685

Number of rotations: 5.00

Gradient/Slope: 0.7937

Number of circles: 0

Start Angle: 0.0000

Rotation direction: Right

OK Reset

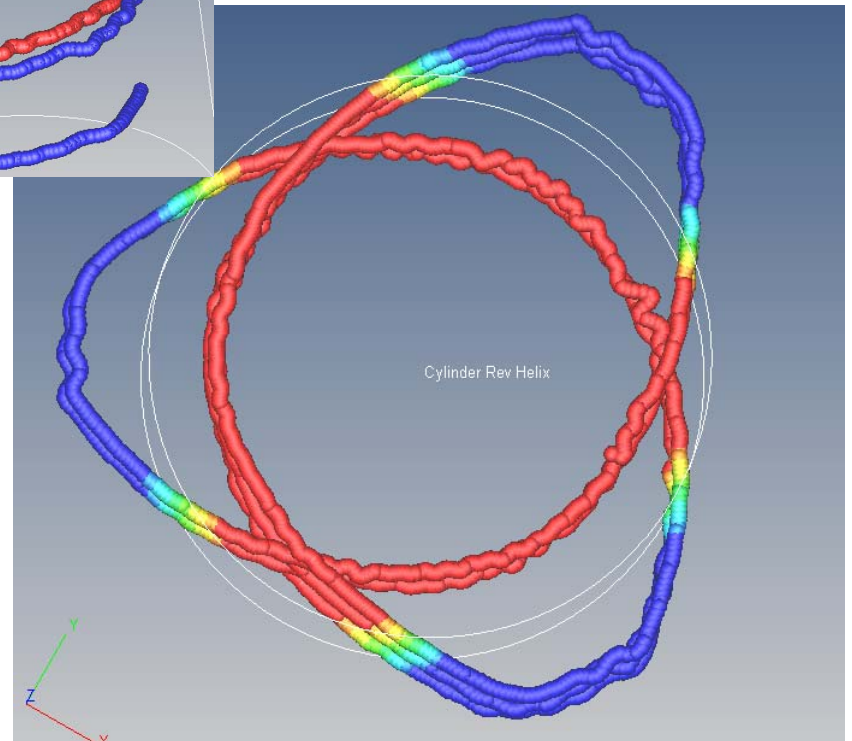
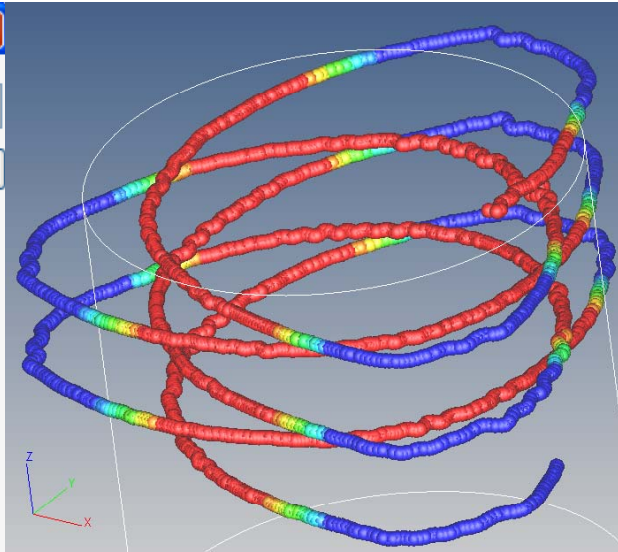

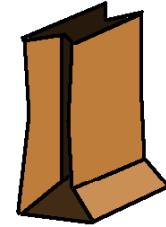
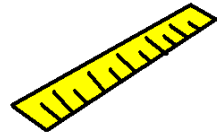

LUNCHEON LEARN

$\frac{1}{4}$ Pitch Helix
Gradient

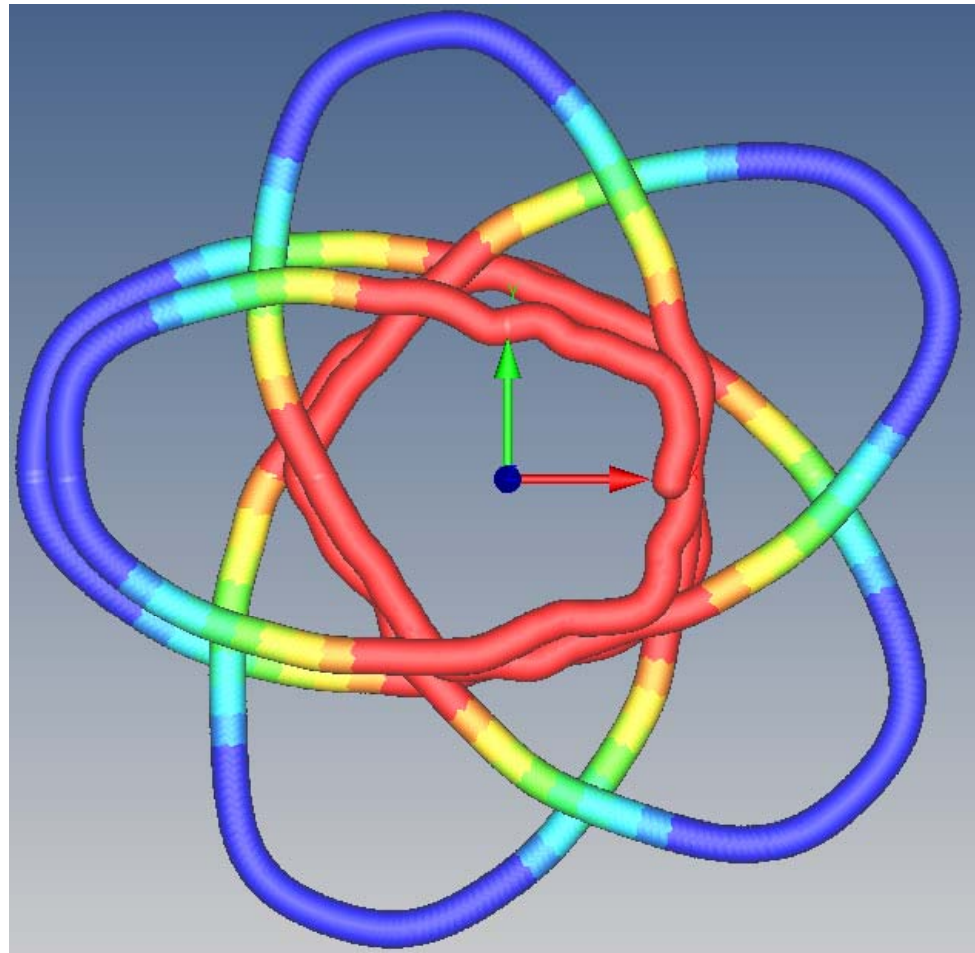

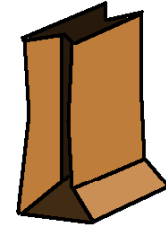
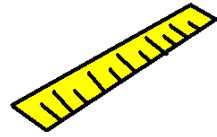

LUNCHEON LEARN

$\frac{1}{2}$ Pitch Helix
Gradient

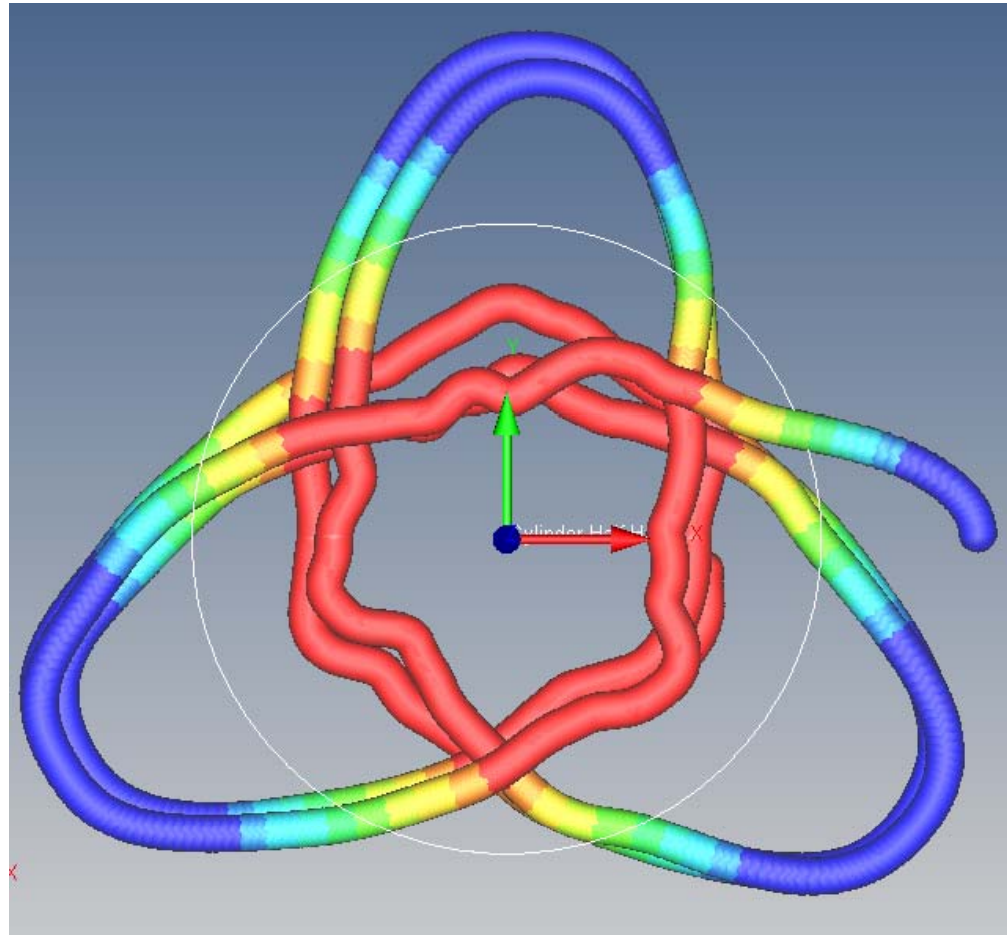

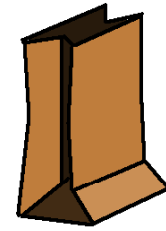
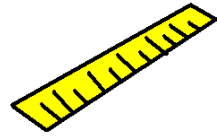

LUNCHEON LEARN

1 Pitch Helix
Gradient

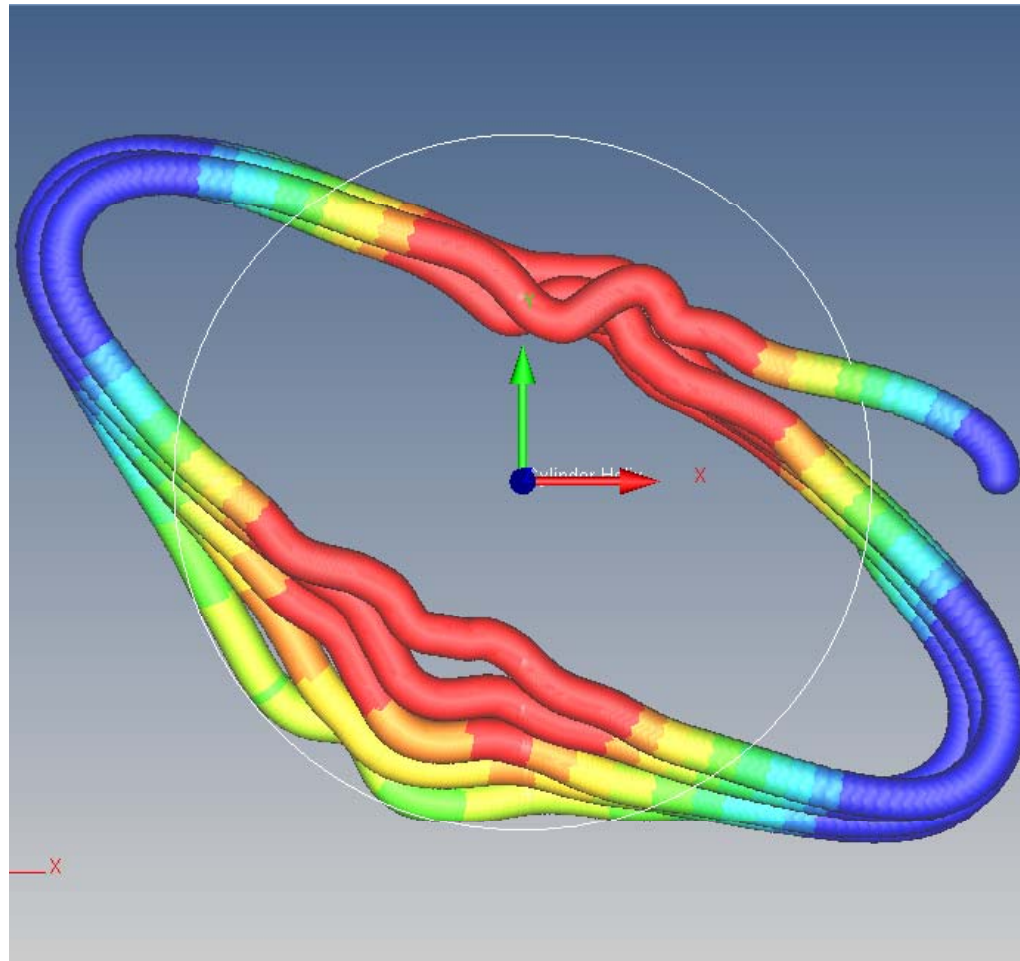

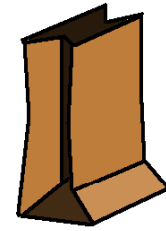
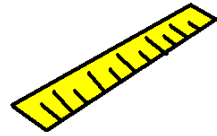

LUNCHEON LEARN

1 1/2 x Pitch
Helix Gradient

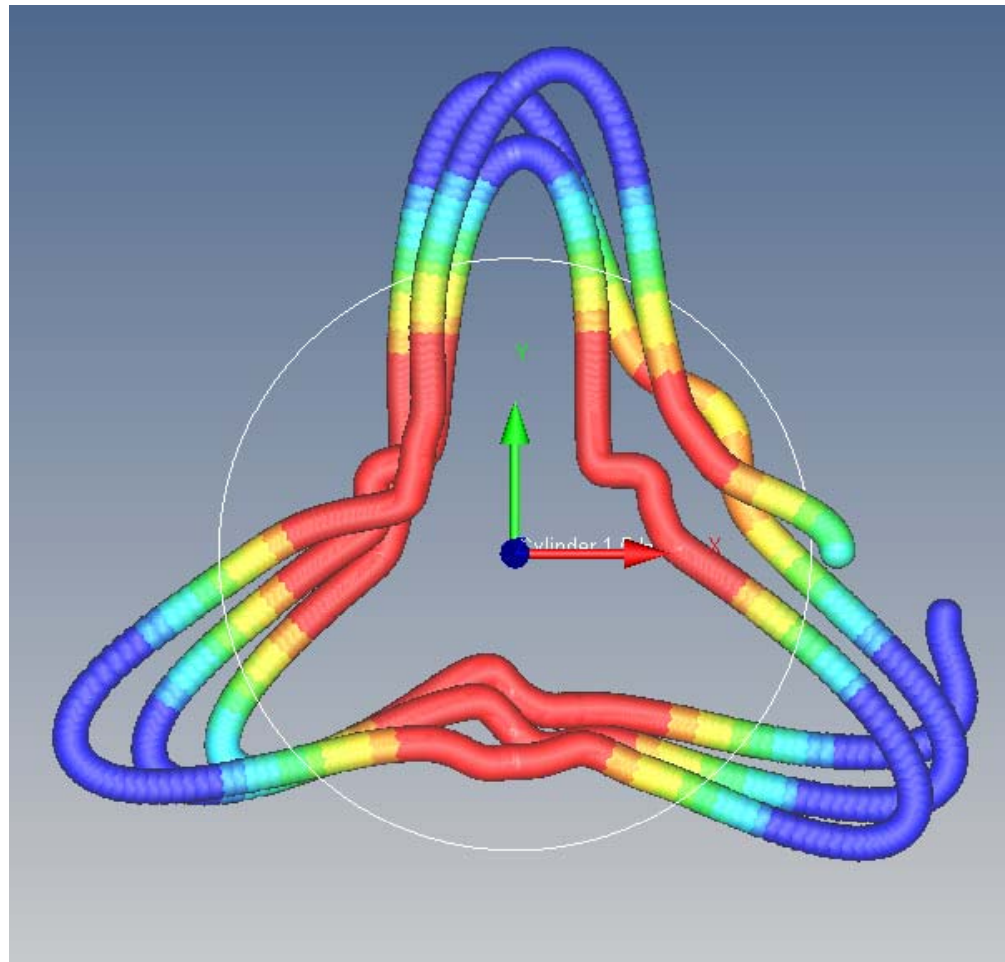

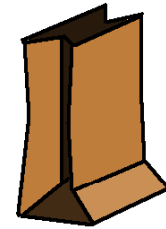
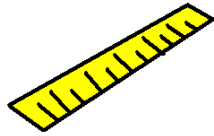

LUNCHEON LEARN

2 x Pitch Helix
Gradient

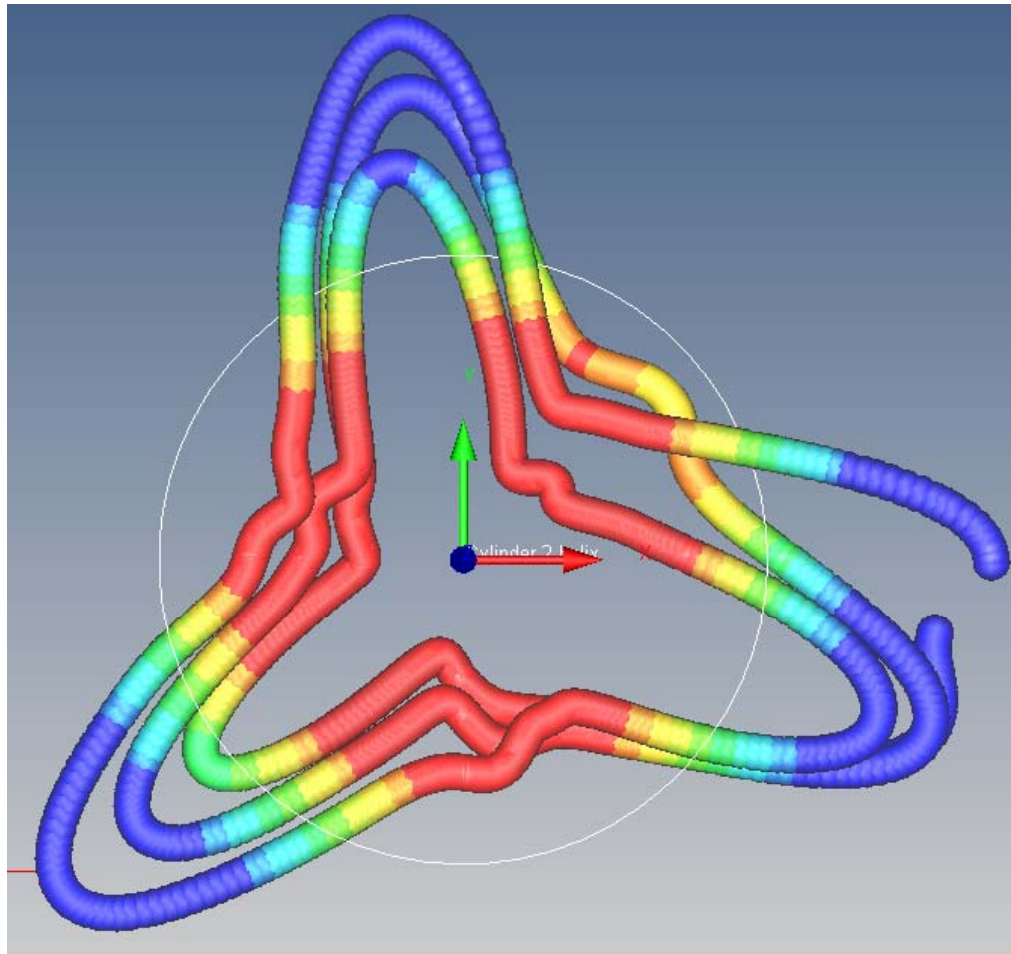

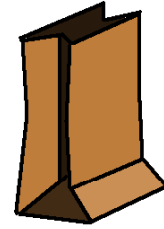
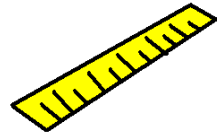

LUNCHEON LEARN

Measurement Strategy #11

Cylinder with self-center Helix.

Concept: stylus will push into the tread, close to pitch diameter.

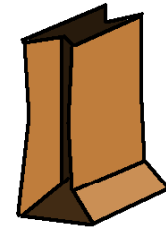
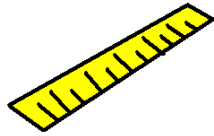

LUNCHEON LEARN

Self Center Probing: Cylinder Self Center

Probe Self Centering

Clamping of the machine axis in

X clamped
 Y clamped
 Z clamped

Measuring force adjustment for rotary table

Probe In Normal Direction
 Own Selection

Fx: 0.0000 mN
Fy: 0.0000 mN
Fz: -200.0000 mN

Coordinates relative to Feature.

Direction of force without rotary table

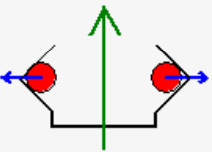

Angle between force direction (blue arrow) and rotation axis (green arrow).

Axis Direction Angle: < >

OK Cancel

OK Reset

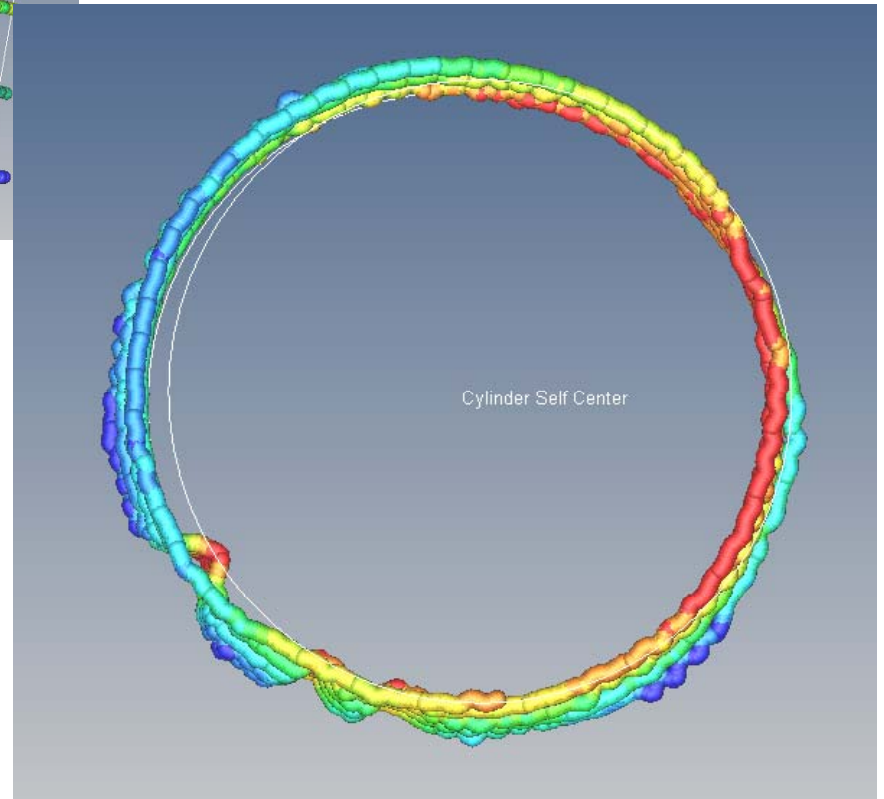
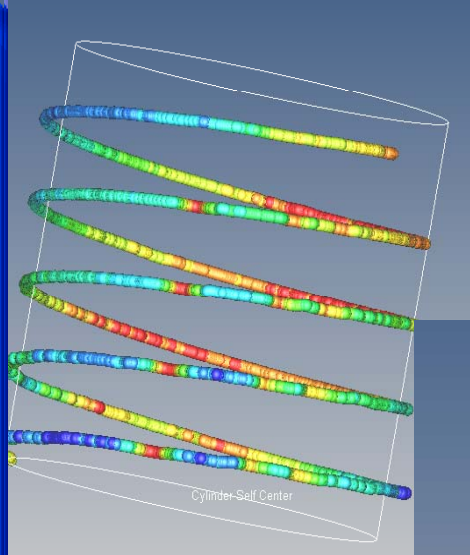

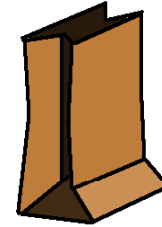
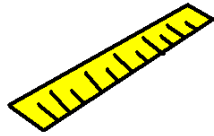

LUNCHEON LEARN

Measurement Plan Editor Features

Time interval after scanning start [sec]

Activate point masking after time interval
Time interval after scanning start [sec]
Time interval before scanning end [sec]
Activate point masking according to the number
Number after scanning start
Number before scanning end

** = from higher setting (Measurement Plan/Group)
!! = Not Available On System

Accept for:
 Measurement Plan selected features

Set To 1

Identifier	Type	Value
Plane1	Plane	** 0.25 (On)
Plane2	Plane	** 0.25 (On)
Plane3	Plane	** 0.25 (On)
Cylinder1	Cylinder	** 0.25 (On)
Intersection1	3-D Poin	** 0.25 (On)
Circle	Circle	** 0.25 (On)
Circle Macro	Circle	** 0.25 (On)
Circle Helix	Circle	** 0.25 (On)
Cylinder 3 Helix	Cylinder	** 0.25 (On)
Cyl 3 Helix at Plane	3-D Poin	** 0.25 (On)
Cylinder 5 Helix	Cylinder	** 0.25 (On)
Cyl 5 Helix at Plane	3-D Poin	** 0.25 (On)
Cylinder DoublePitch	Cylinder	** 0.25 (On)
Cyl Doublepitch at Plane	3-D Poin	** 0.25 (On)
Cylinder Linear	Cylinder	** 0.25 (On)
Cyl Linear at Plane	3-D Poin	** 0.25 (On)
Cylinder Rev Helix	Cylinder	** 0.25 (On)
Cyl Rev Helix at Plane	3-D Poin	** 0.25 (On)
Cylinder Self Center	Cylinder	1 (On)
Cyl Self Center at Plane	3-D Poin	1 (On)

OK Cancel Help

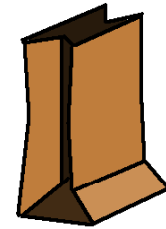
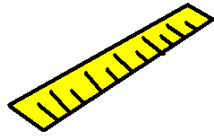

LUNCHEON LEARN

More testing!

remove/replace plug.

5 runs, 5mm stylus

5 runs, 3mm stylus

Plug Average is nominal.

Try 3 different parts.

(Accura, 0.200mm tol)

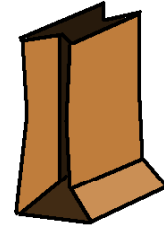
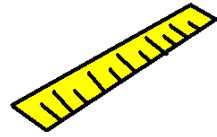

LUNCHEON LEARN

Part 1:



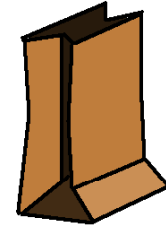
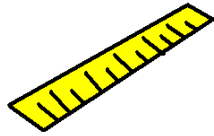

LUNCHEON LEARN

3mm
stylus

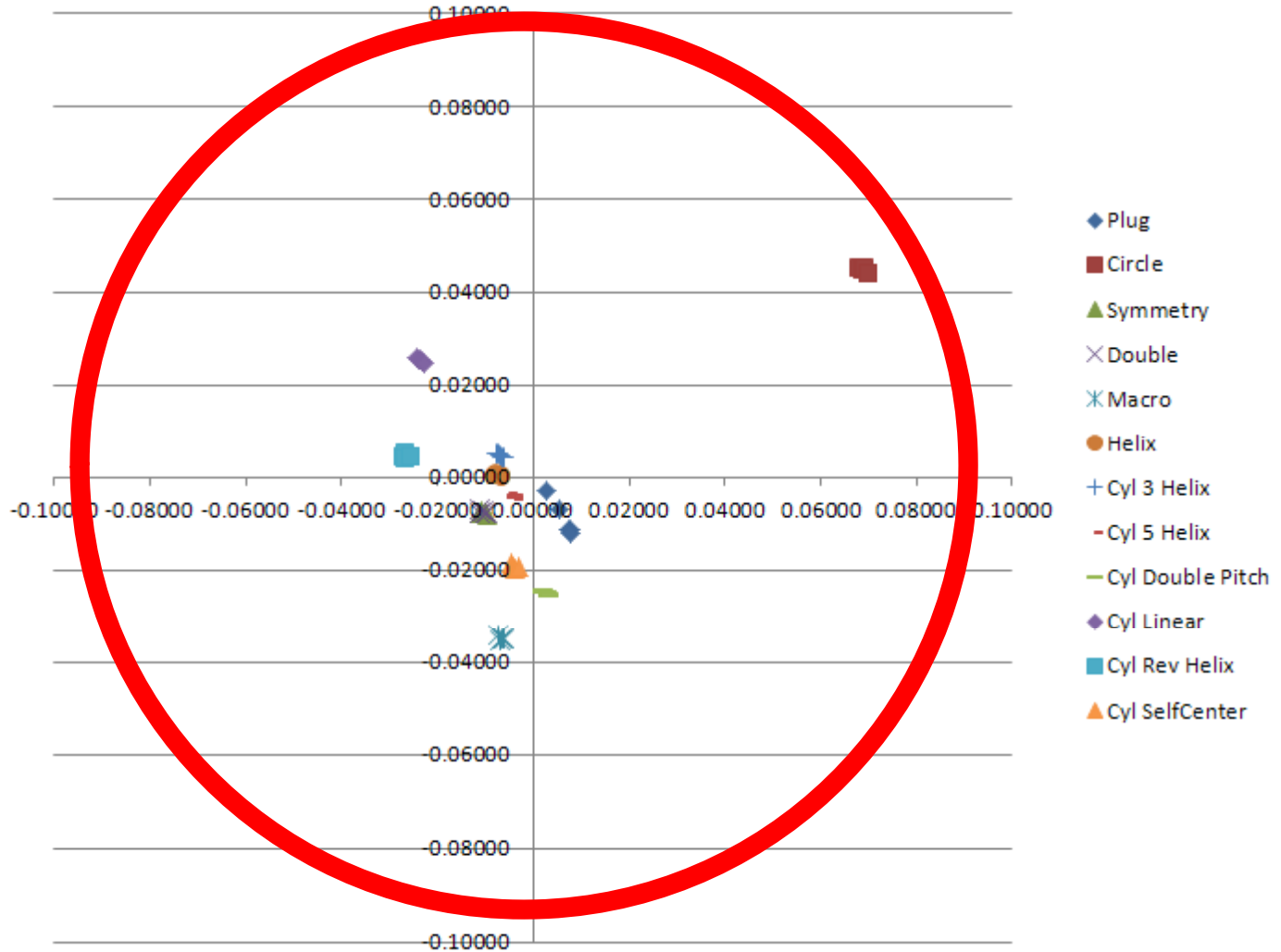

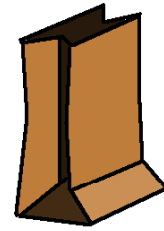
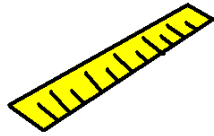

LUNCHEON LEARN

5mm
stylus

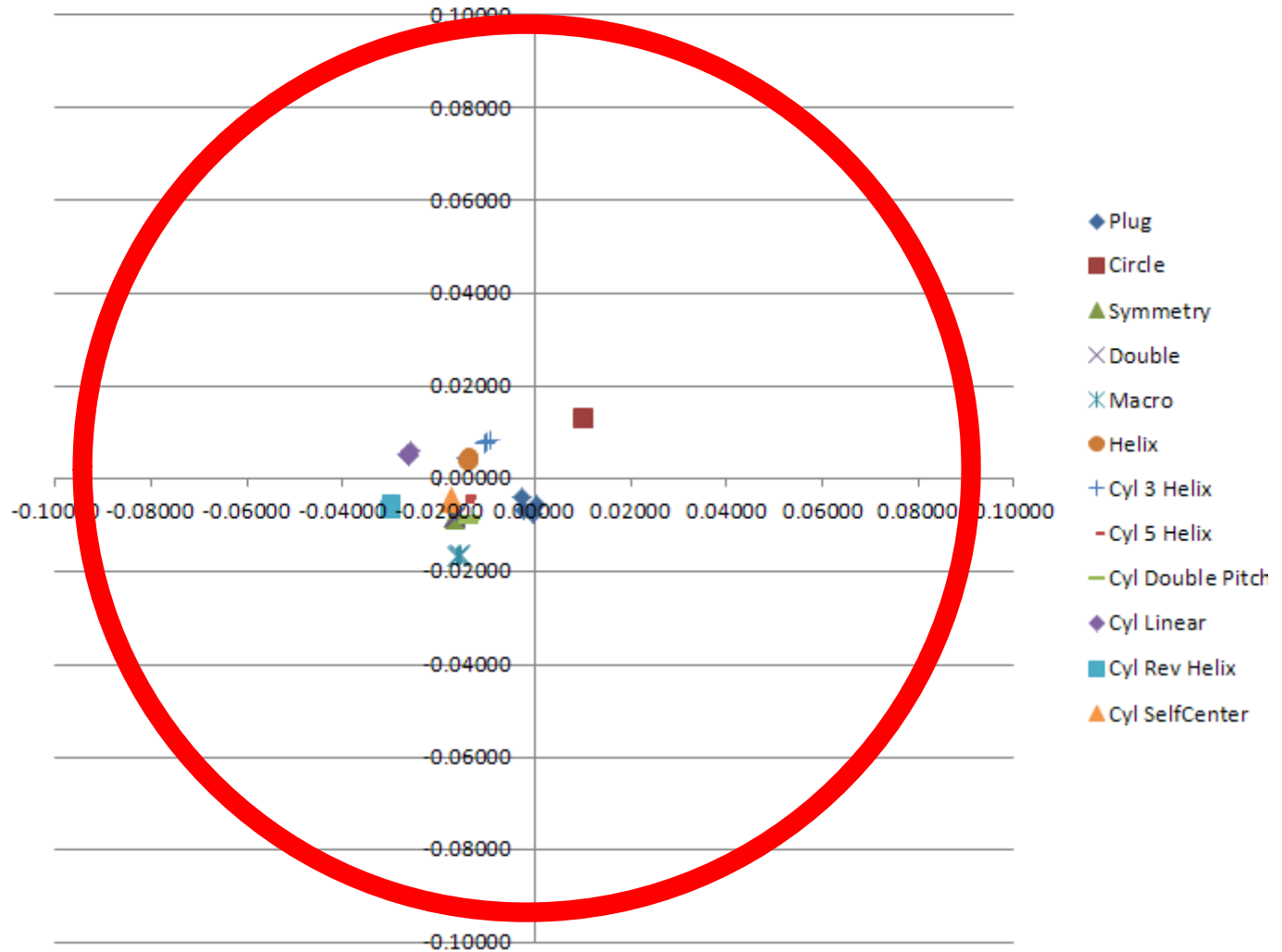

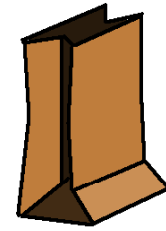
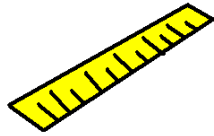

LUNCHEON LEARN

All 10
results

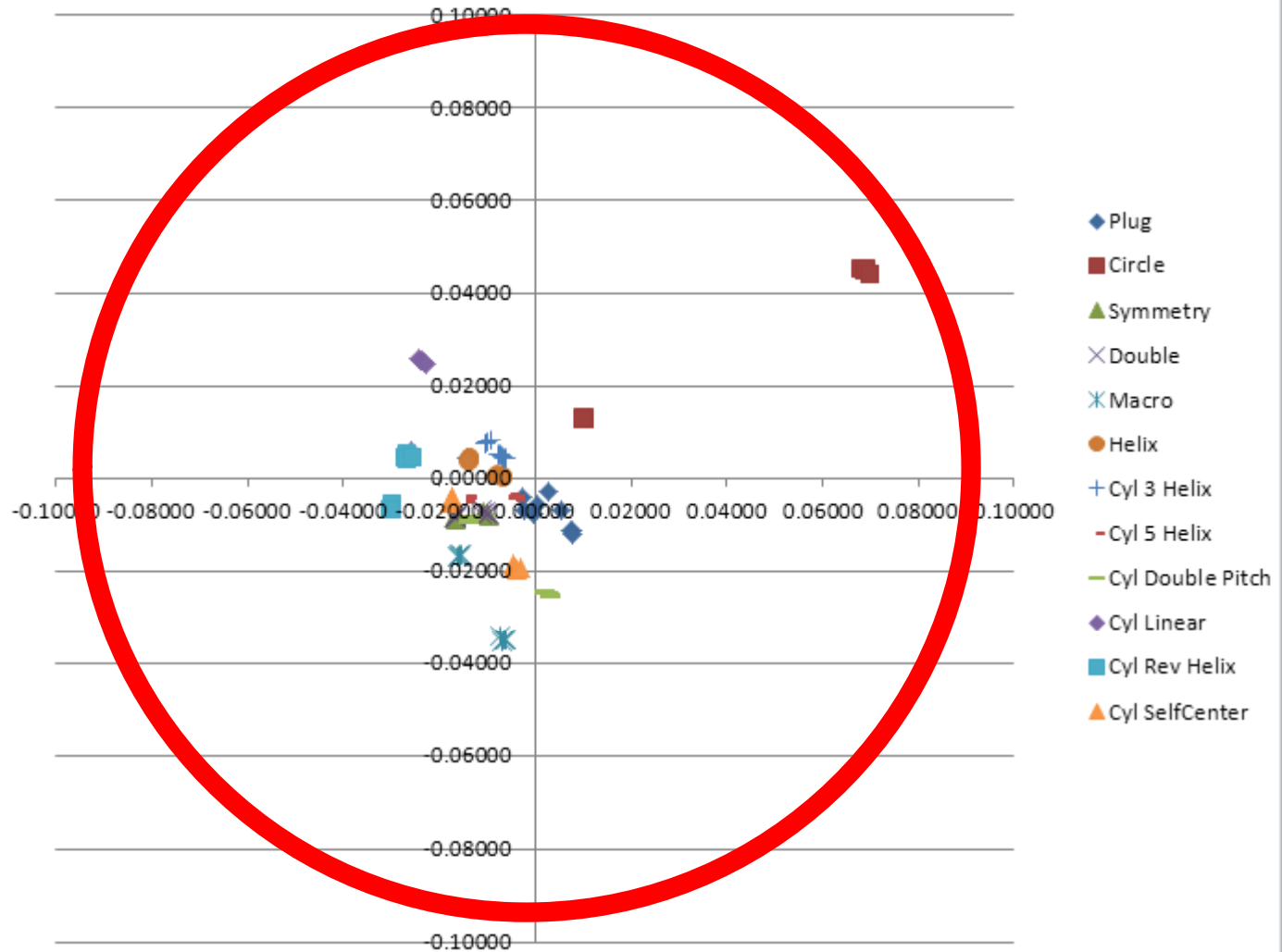

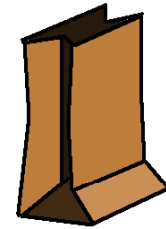
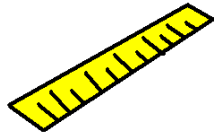

LUNCHEON LEARN

	Nominal	Upper Tol	Range	Average
True Position Pin	0.000	0.200	0.021	0.000
True Position Cyl 5 Helix at Plane	0.000	0.200	0.019	0.021
True Position Cyl Doublepitch at Plane	0.000	0.200	0.020	0.025
True Position Cyl Self Center at Plane	0.000	0.200	0.005	0.026
True Position Circle Helix	0.000	0.200	0.016	0.029
True Position Symmetry	0.000	0.200	0.013	0.030
True Position Double	0.000	0.200	0.013	0.030
True Position Cyl 3 Helix at Plane	0.000	0.200	0.011	0.032
True Position Circle Macro	0.000	0.200	0.026	0.046
True Position Cyl Rev Helix at Plane	0.000	0.200	0.010	0.060
True Position Cyl Linear at Plane	0.000	0.200	0.018	0.068
True Position Circle	0.000	0.200	0.133	0.104

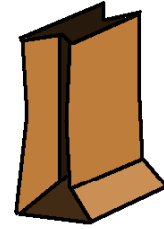
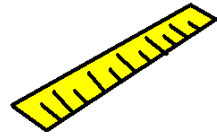

LUNCHEON LEARN

Part 2 :



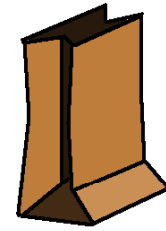
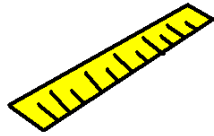

LUNCHEON LEARN

3mm
stylus

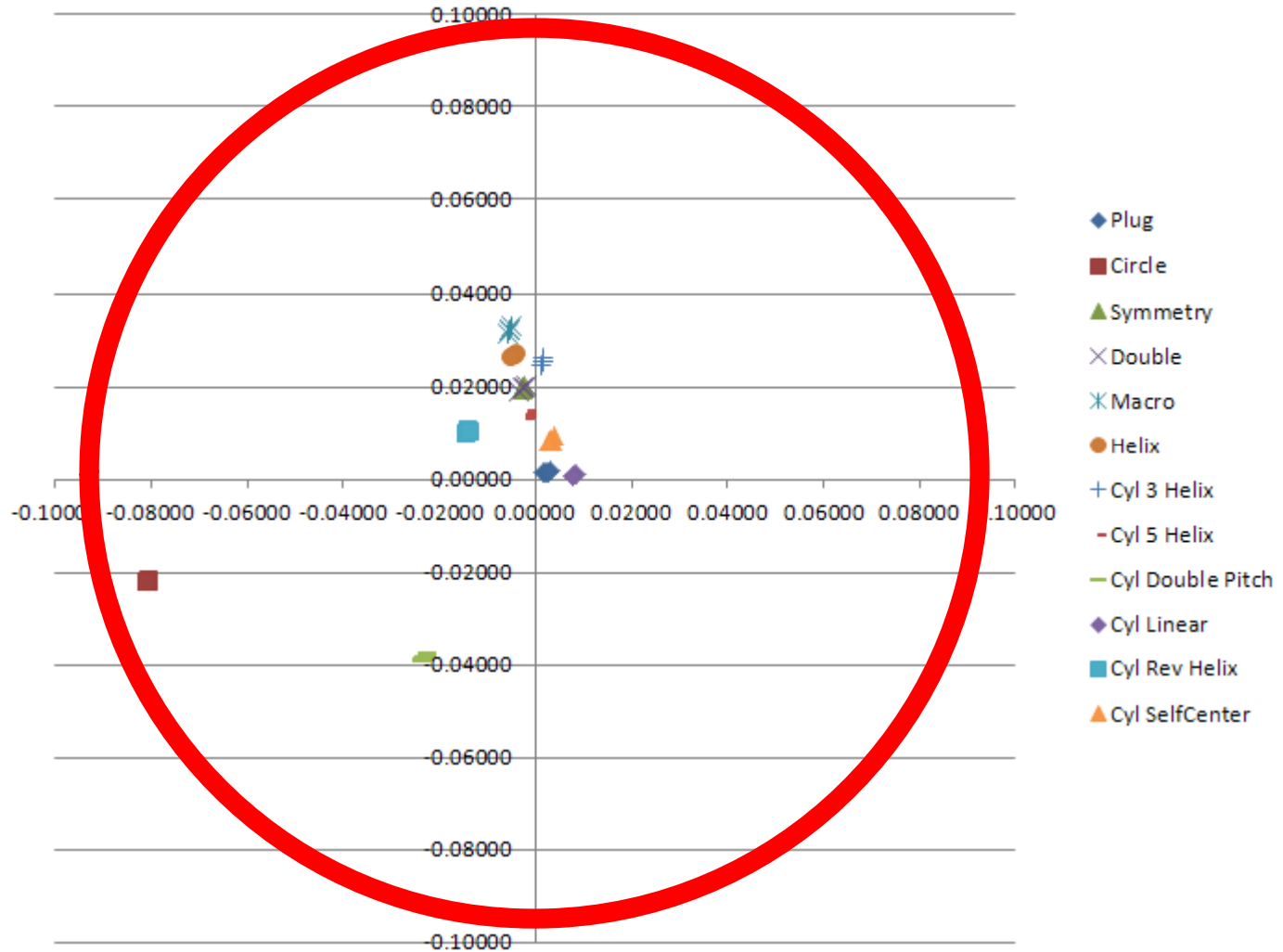

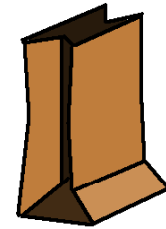
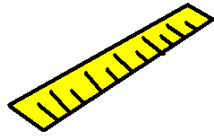

LUNCHEON LEARN

5mm
stylus

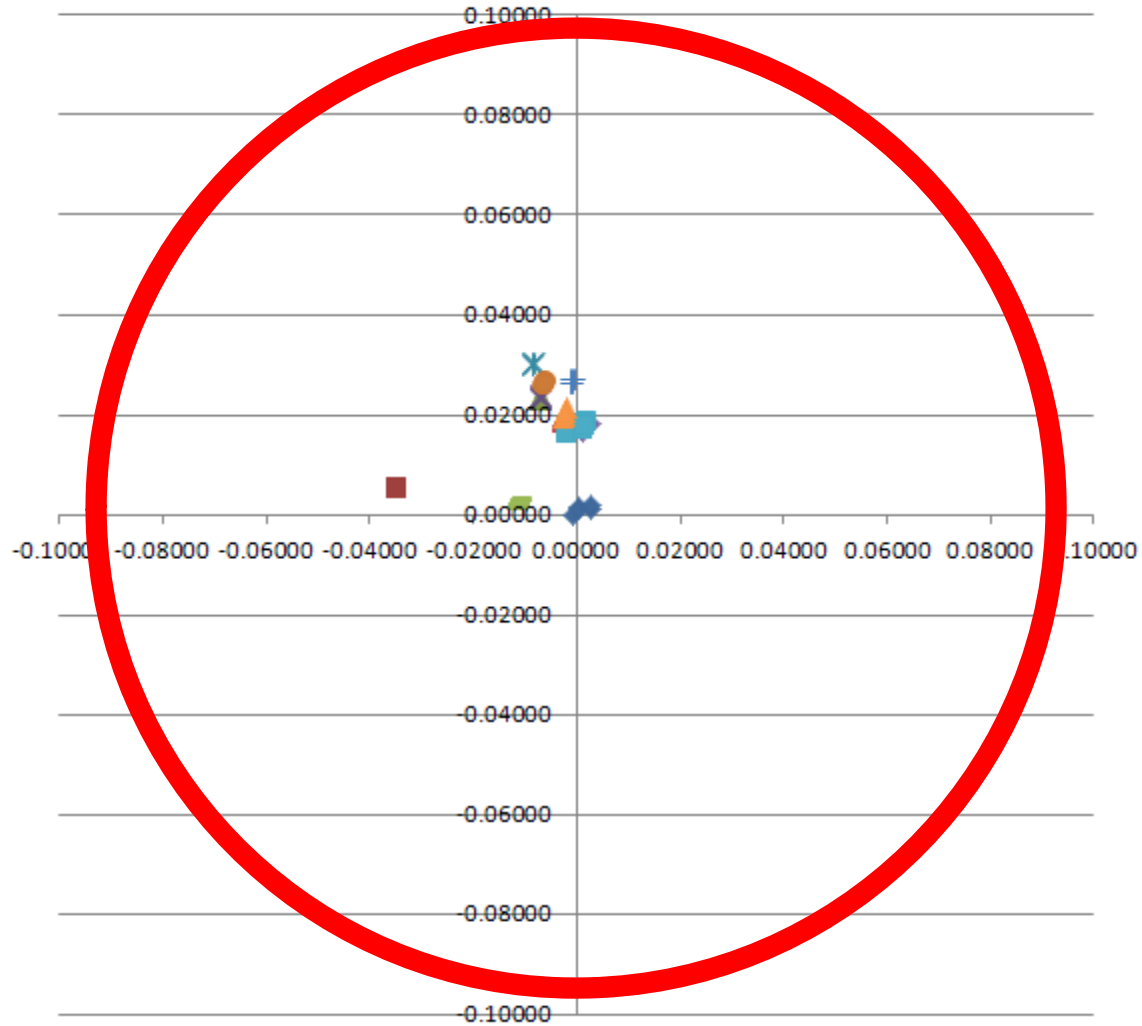

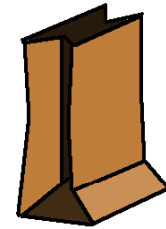
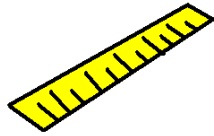

LUNCHEON LEARN

All 10
results

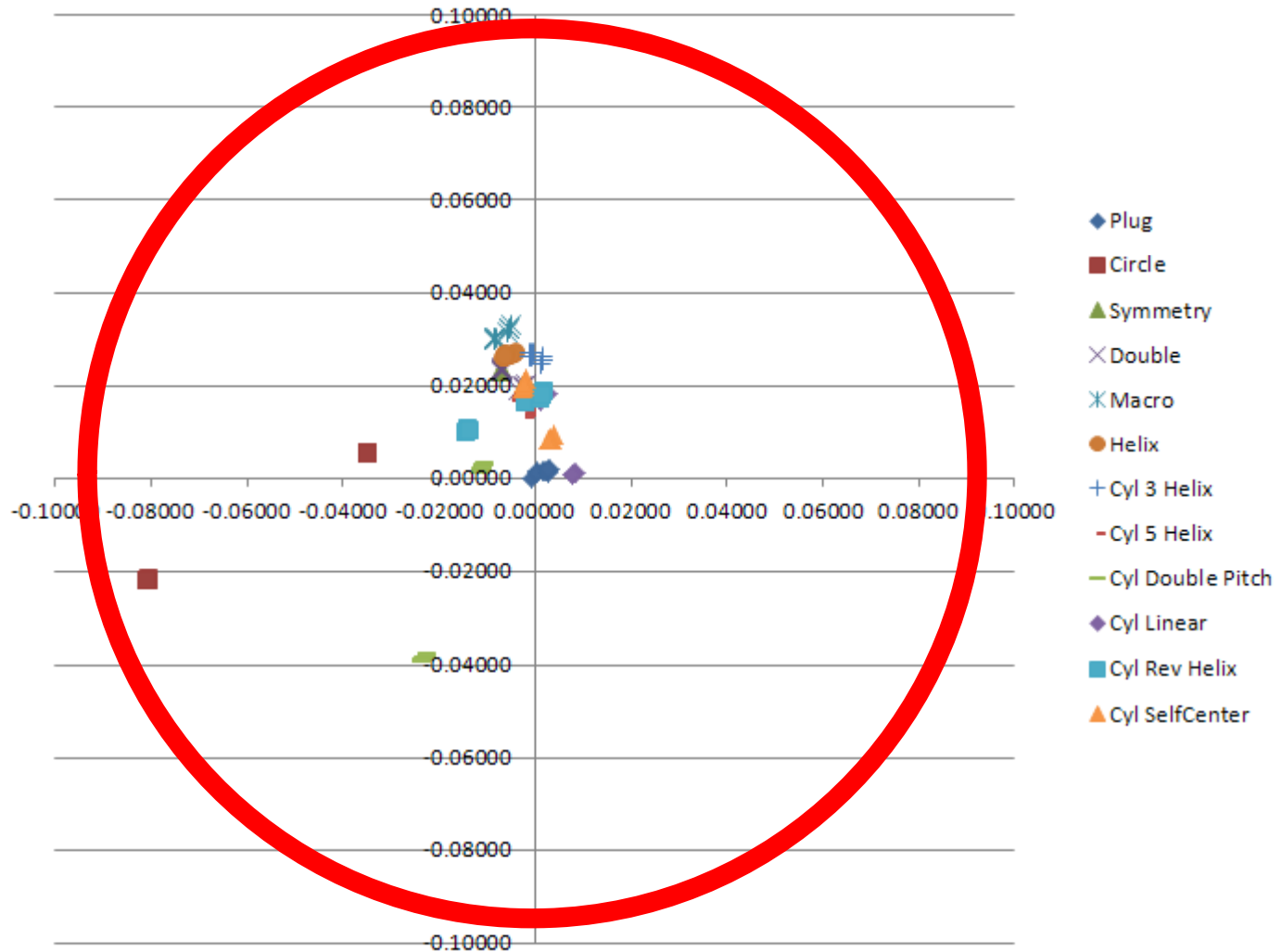

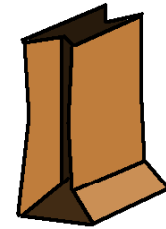
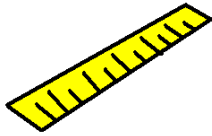

LUNCHEON LEARN

	Nominal	Upper Tol	Range	Average
True Position Pin	0.000	0.200	0.005	0.000
True Position Cyl Linear at Plane	0.000	0.200	0.022	0.017
True Position Cyl Self Center at Plane	0.000	0.200	0.026	0.027
True Position Cyl Rev Helix at Plane	0.000	0.200	0.005	0.030
True Position Cyl 5 Helix at Plane	0.000	0.200	0.010	0.031
True Position Double	0.000	0.200	0.010	0.042
True Position Symmetry	0.000	0.200	0.010	0.043
True Position Cyl 3 Helix at Plane	0.000	0.200	0.005	0.050
True Position Circle Helix	0.000	0.200	0.002	0.052
True Position Cyl Doublepitch at Plane	0.000	0.200	0.069	0.053
True Position Circle Macro	0.000	0.200	0.005	0.062
True Position Circle	0.000	0.200	0.098	0.120

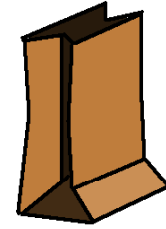
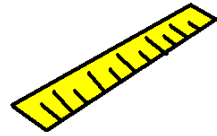

LUNCHEON LEARN

Part 3 :



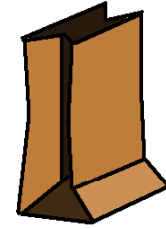
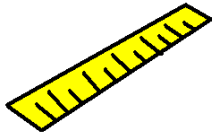

LUNCHEON LEARN

3mm
stylus

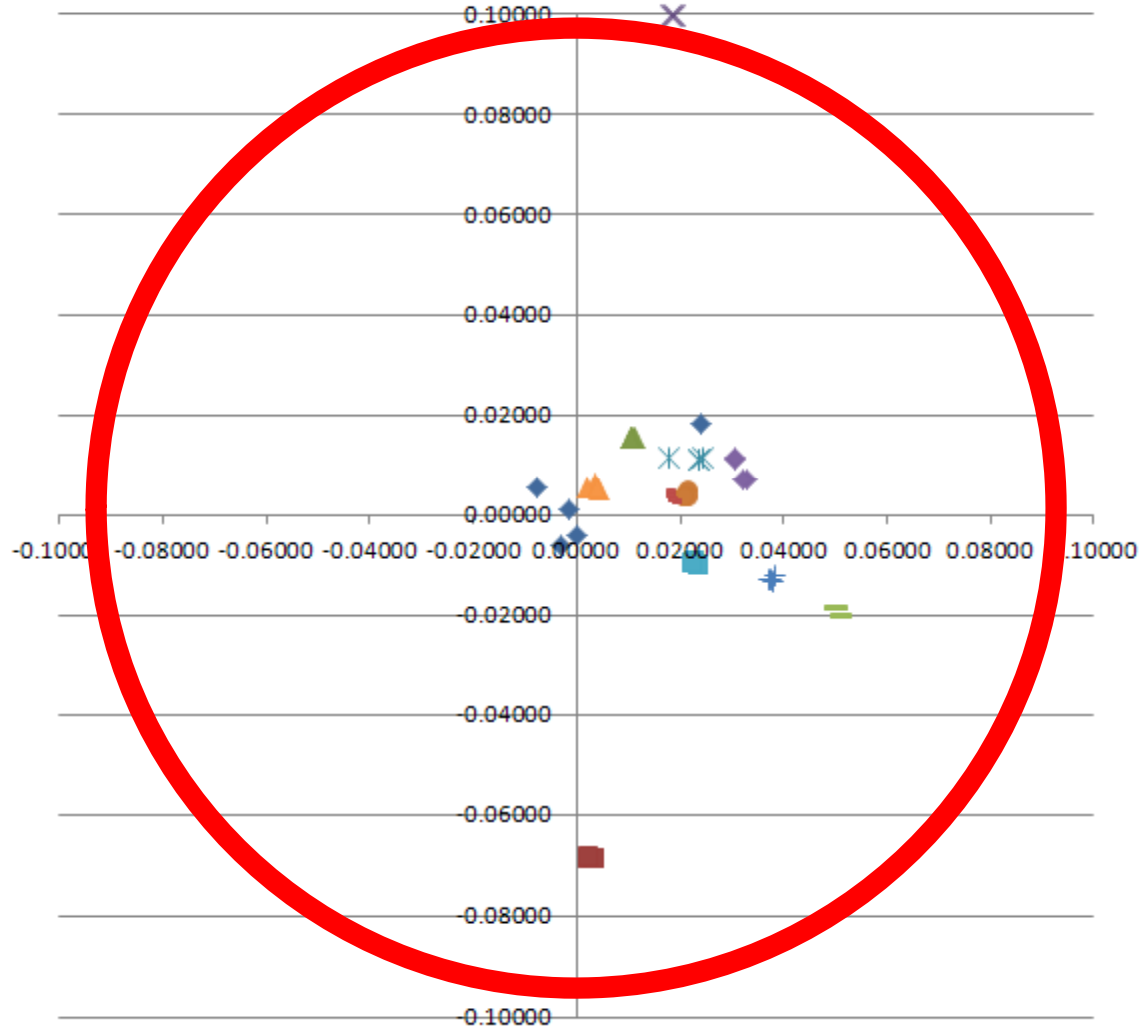

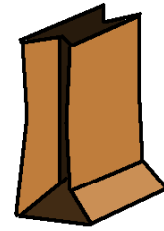
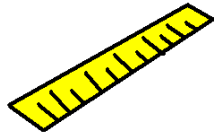

LUNCHEON LEARN

5mm
stylus

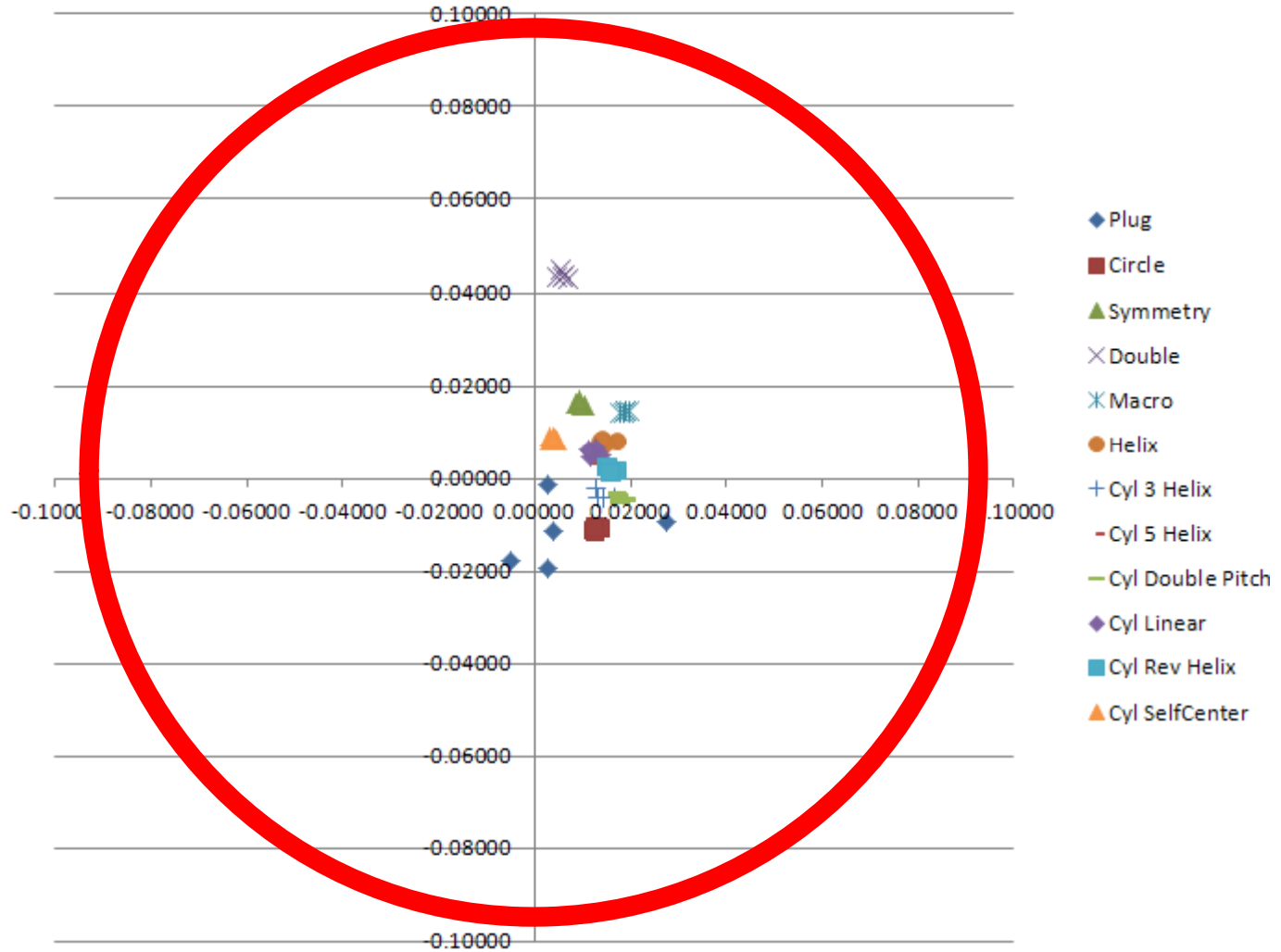

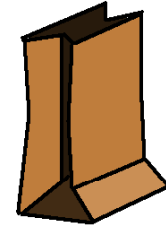
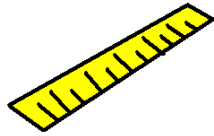

LUNCHEON LEARN

All 10
results

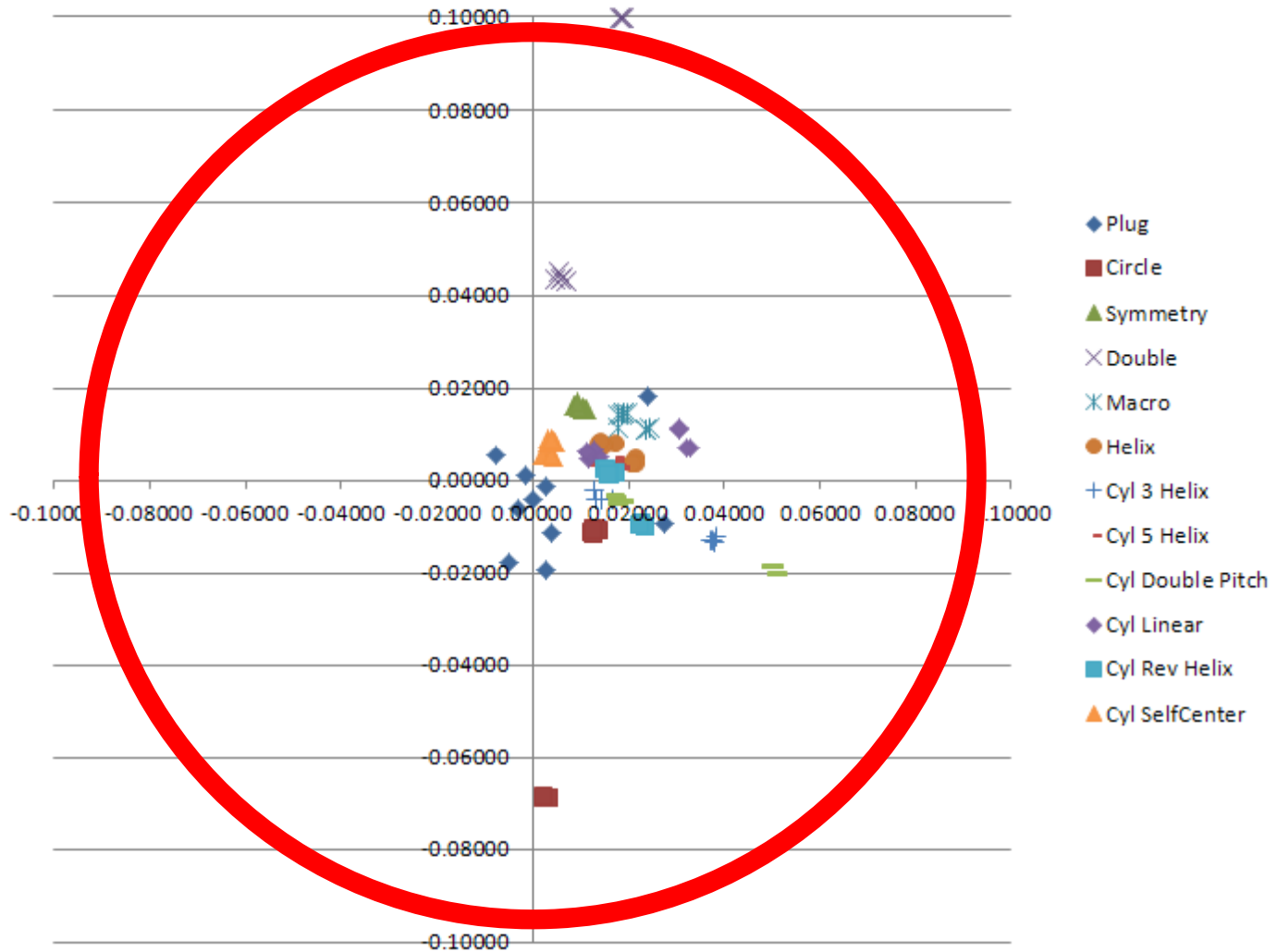

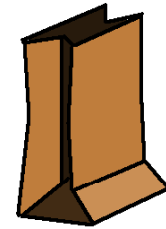
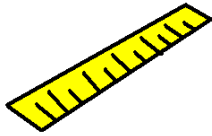

LUNCHEON LEARN

	Nominal	Upper Tol	Range	Average
True Position Pin	0.000	0.200	0.057	0.000
True Position Cyl Self Center at Plane	0.000	0.200	0.008	0.023
True Position Cyl 5 Helix at Plane	0.000	0.200	0.013	0.027
True Position Cyl Rev Helix at Plane	0.000	0.200	0.021	0.031
True Position Circle Helix	0.000	0.200	0.012	0.035
True Position Symmetry	0.000	0.200	0.002	0.042
True Position Cyl Linear at Plane	0.000	0.200	0.042	0.043
True Position Cyl 3 Helix at Plane	0.000	0.200	0.055	0.044
True Position Circle Macro	0.000	0.200	0.012	0.048
True Position Cyl Doublepitch at Plane	0.000	0.200	0.075	0.062
True Position Circle	0.000	0.200	0.105	0.071
True Position Double	0.000	0.200	0.117	0.154

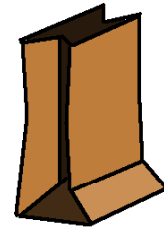
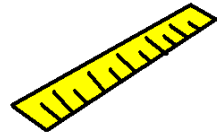

LUNCHEON LEARN

Now, you are thinking to yourself...

“I just sat through 105 slides – what is the conclusion?”

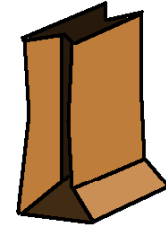
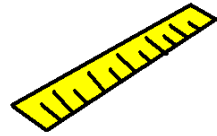

LUNCHEON LEARN

What's Important to You and your company?

- “Accuracy” compared to Flex Plug?
- Repeatability?
- TIME?

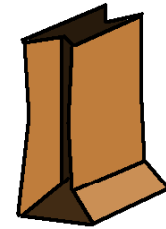
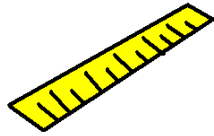

LUNCHEON LEARN

Location Deviation (all Tests)

	Average Avg
True Position Pin	0.000
True Position Cyl Self Center at Plane	0.025
True Position Cyl 5 Helix at Plane	0.026
True Position Symmetry	0.038
True Position Circle Helix	0.039
True Position Cyl Rev Helix at Plane	0.040
True Position Cyl 3 Helix at Plane	0.042
True Position Cyl Linear at Plane	0.042
True Position Cyl Doublepitch at Plane	0.047
True Position Circle Macro	0.052
True Position Double	0.075
True Position Circle	0.099

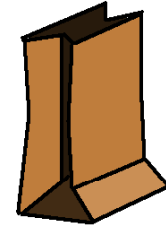
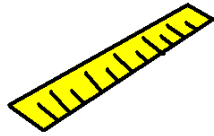

LUNCHEON LEARN

Repeatability (all Tests)

	Range Avg
True Position Symmetry	0.008
True Position Circle Helix	0.010
True Position Cyl Rev Helix at Plane	0.012
True Position Cyl Self Center at Plane	0.013
True Position Cyl 5 Helix at Plane	0.014
True Position Circle Macro	0.014
True Position Cyl 3 Helix at Plane	0.024
True Position Cyl Linear at Plane	0.027
True Position Pin	0.028
True Position Double	0.046
True Position Cyl Doublepitch at Plane	0.055
True Position Circle	0.112

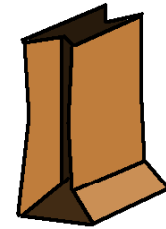
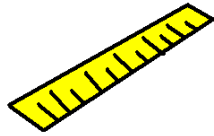

LUNCHEON LEARN

Inspection Time per Hole

	Time (sec)
True Position Circle Helix	4.000
True Position Circle	4.000
True Position Circle Macro	5.000
True Position Cyl 3 Helix at Plane	7.000
True Position Symmetry	9.000
True Position Double	9.000
True Position Cyl 5 Helix at Plane	10.000
True Position Cyl Rev Helix at Plane	10.000
True Position Cyl Self Center at Plane	14.000
True Position Cyl Linear at Plane	17.000
True Position Cyl Doublepitch at Plane	18.000
True Position Pin	30.000

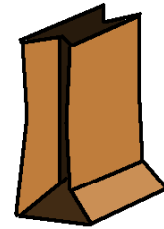
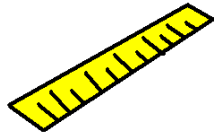

LUNCHEON LEARN

Notes:

Use LSQ fitting to eliminate the effect of “junky” threads

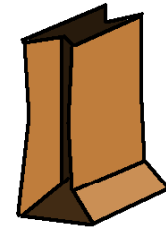
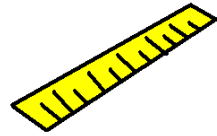

LUNCHEON LEARN

Notes:

Use of the Flex Plug “wore” the thread geometry to some degree – shavings on the plug were evident after use, especially with aluminum parts

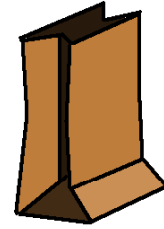
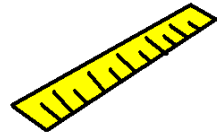

LUNCHEON LEARN

Conclusion:

There is no “Perfect” solution to gaging the location of threaded holes on a CMM.

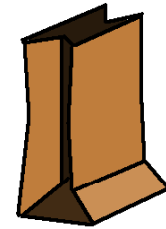
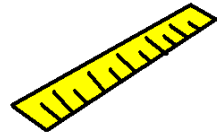

LUNCHEON LEARN

Conclusion:

If you have the time and money and can afford repeatability issues, use the flex plug.

It's the only way to theoretically measure location based on thread face Surfaces

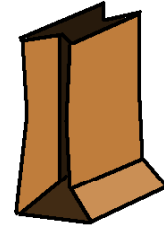
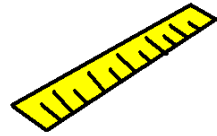

LUNCHEON LEARN

Conclusion:

If you have the time, the best way to match a flex plug is self-center scan a helical cylinder up the thread with at least 5 revolutions.

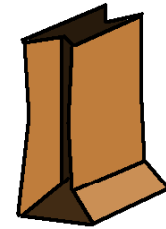
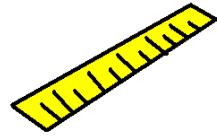

LUNCHEON LEARN

Conclusion:

If cycle time is important, just measure a circle with one revolution with a helix with the gradient of the pitch.

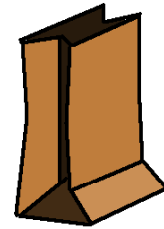
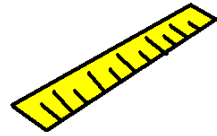

LUNCHEON LEARN

Conclusion:

Use as large a stylus as possible.
Measurements “converged” closer to the target center when a larger tip was used, regardless of measurement method.

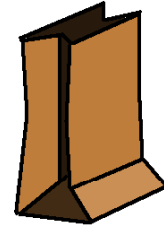
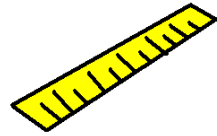

LUNCHEON LEARN

Conclusion:

Repeatability of ANY method on the CMM (with any one stylus size) is always better than repeatability of a flex plug.

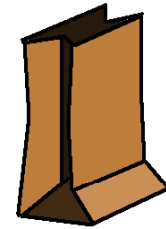
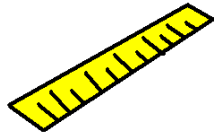

LUNCHEON LEARN

Disclaimer:

The conclusions displayed here are representative of the data gathered in this testing.

Before choosing a method of inspecting threads, it is recommended to test and verify your results on your parts.

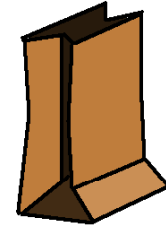
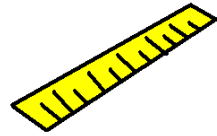

LUNCHEON LEARN

You've got Questions, We have answers.

Measuring Threaded Holes