

A183726

NASA  
Contractor Report 4083

AVSCOM  
Technical Report 87-C-11

# Automated Inspection and Precision Grinding of Spiral Bevel Gears

Harold Frint  
*Sikorsky Aircraft Division*  
*United Technologies Corporation*  
*Stratford, Connecticut*

Prepared for  
Propulsion Directorate  
USAARTA-AVSCOM and  
NASA Lewis Research Center  
under Contract NAS3-25465

DTIC  
SELECTED  
AUG 21 1987  
A

**NASA**  
National Aeronautics  
and Space Administration  
  
Scientific and Technical  
Information Office

1987

This document has been approved  
for public release and sale; its  
distribution is unlimited.



## PREFACE

This report presents the results of a four-phase program to develop an improved inspection method for spiral bevel gears. Phase I covers the definition and development of a final inspection method utilizing a multi-axis coordinate measuring machine. Phase II involves the extension of the method to in-process inspection of spiral bevel gears. A pilot production program was conducted in Phase III and final documentation was performed in Phase IV.

The work outlined herein was performed under U.S. Army Aviation Systems Command Contract NAS3 25465 under the technical monitorship of Daniel Pauze, U.S. Army Propulsion Laboratory, Cleveland, Ohio.

This program was conducted by Sikorsky Aircraft, Division of United Technologies, under the technical direction of Alphonse Lemanski, Program Manager, and J. Mancini, Chief of Design and Development of Transmissions. Principal investigators were Harold Frint, Senior Design Analyst, and Warren Glasow, Senior Manufacturing Research Engineer.

Acknowledgement is made to Theodora Krenzer and James Knope of the Gleason Works, Rochester, New York for their support and especially for the use of the Gleason-developed software package.

## TABLE OF CONTENTS

	<u>Page</u>
SUMMARY	iii
PREFACE	v
INTRODUCTION	1
STATE OF THE ART OF SPIRAL BEVEL GEAR MANUFACTURE	3
DEVELOPMENT OF A FINAL INSPECTION METHOD	10
Bevel Gear Selection	10
Test Gear Specimens	13
Universal Multi-Axis Coordinate Measuring Machine	13
Master Gear Data	18
The Final Inspection Measurement Process	21
Determination of Nominal Values	21
The Measurement Process	22
Measurement Results	23
Discussion of Results	36
Correlation with Taped Patterns	36
Comparison of Nominal Values	37
DEVELOPMENT OF AN IN-PROCESS INSPECTION TECHNIQUE	42
G-Age Corrective Process	42
Sensitivity Study	42
Fabrication of Test Gear Specimens	42
The Measurement Process	44
Results of Corrective Regrinds	44
Discussion of Results	49
Establishment of Tolerance Limits	49
PILOT PRODUCTION AND TEST PROGRAM	51
Fabrication of Pilot Production Test Gears	51
Inspection Results Configuration 1	51
Inspection Results Configuration 2	51
Inspection Results Configuration 3	51
H-60 Main Test Facility	55
Acceptance Test Program	55
Test Results	55
Discussion of Results	57
ECONOMIC COST ANALYSIS	60
Basis for Economic Analysis	60
Income/Expense Statement	60
Results	60
CONCLUSIONS	64
APPENDIX I      PROCESS SPECIFICATION	65

## INTRODUCTION

Proper and reliable service from a pair of spiral bevel gears can be obtained only when they are manufactured accurately and mounted into precision-machined gearbox housings that position and maintain the driving and driven gear members in a specified three-dimensional relationship throughout their useful life. Gears produced on existing gear generating and grinding equipment will run smoothly and carry the design load without distress if tooth spacing is maintained, the teeth are machined concentric with the rotating axis, and the tooth profile contour is controlled so that maximum tooth pair conjugacy is achieved when operating under full load conditions.

Since it is impractical to design and fabricate gear teeth and gear mounts that are free from deflections when operating under load, most high-power gears are designed with tooth profile modifications along the tooth face and in the profile direction to compensate for load-induced deformations and to prevent load concentration at the ends or tips of the teeth resulting in excessive wear, scoring, or even tooth breakage.

The elemental inspection of tooth profiles that is commonly performed on spur and helical gears is not practical for spiral bevel gears because the shape and size of a bevel gear tooth varies over its face width instead of being constant as in the case of a spur gear. Spiral bevel gears are currently inspected on a specifically-designed Gleason test machine, shown in Figure 1, which provides a rotating test of the gear pair simulating no-load operation under actual gearbox mounting conditions. Tooth contact patterns under these rotating conditions can be observed by painting the teeth with a marking compound and running the gears with their mating master control gears for a few seconds in the gear tester with a light brake load. Because of the compound curvatures inherent in the spiral bevel gear tooth form and the profile modifications designed into the tooth, these gears typically exhibit a localized composite tooth contact which, ideally, should spread out under full load, filling the working area of the tooth with some easing off at the end areas of contact. The size, shape, and position of this tooth bearing pattern is a gross indication of the tooth topology both up and down the tooth profile and lengthwise along the tooth face.

The task of the design and profile development phase of spiral bevel gear manufacture is to obtain a localized test machine pattern of a size, shape, and location that will produce the desired full load contact pattern when run in the gearbox. The task of the gear production phase is the consistent duplication of this tooth shape during a production run and from one production run to another.

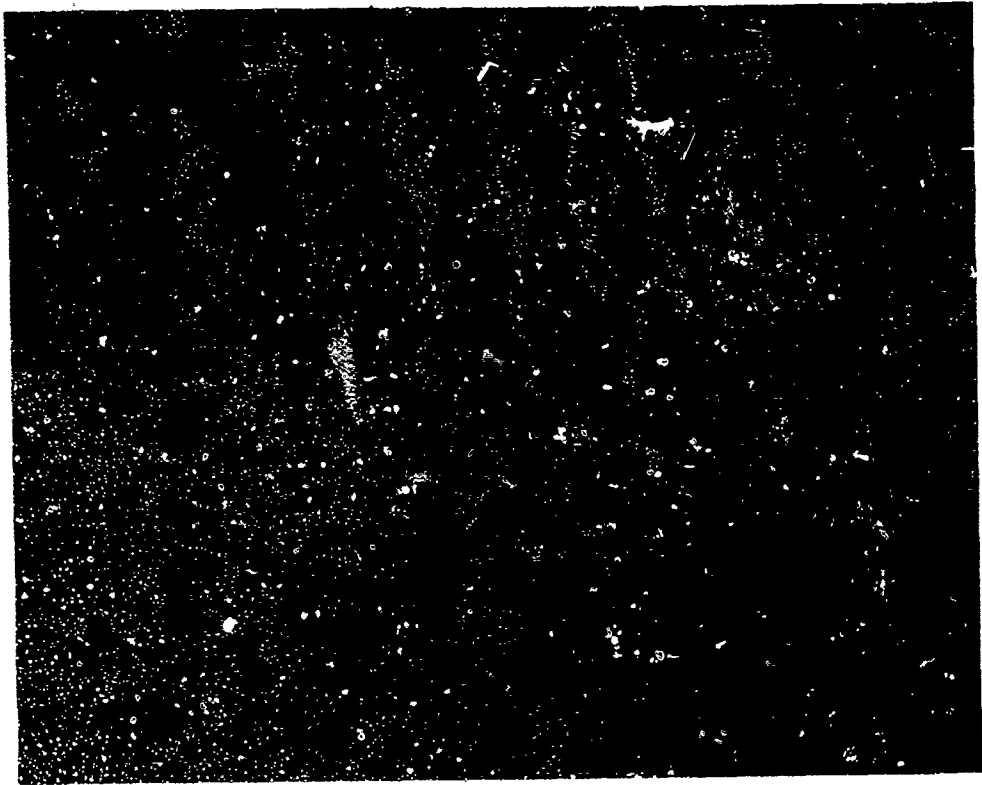

Figure 1. Gleason Test Machine

## STATE OF THE ART OF SPIRAL BEVEL GEAR MANUFACTURE

This current method of manufacturing primary drive spiral bevel gears requires an experienced and qualified organization. It is often expressed that the development of a spiral bevel gear is more of an art than a science. This expression is based on the requirement for skilled bevel gear machine operators who must use their background experience to evaluate the position, shape and contour of the gear tooth contact pattern produced by the rolling test in the test machine. The machine operator's judgment is relied upon to determine what grinding machine setting or combination of settings is best used to correct an undesirable feature in the test pattern.

The Gleason gear grinding process is a culmination of motions and tool paths that generate the bevel gear tooth form into a continually varying noninvolute curve. Basically, the Gleason gear grinder, shown in Figure 2, has a cradle that supports the formed grinding wheel shown and a radial oscillating motion while the wheel moves in and out of the gear tooth space. This cradle motion is controlled by a generating cam that can be adjusted through the cradle angle setting to modify the ratio of motion at one end of the oscillating arc in relation to the other end. The gear to be ground is mounted on a work holding fixture precisely centered to the work spindle that is in constant rotational motion in a controlled ratio to the cradle. The grinding wheel is mounted concentric to the cradle axis (see Figure 3) in a fixed relative position to the cradle center dependent upon the wheel radius, the spiral angle, and hand of spiral. The grinding wheel, in effect, acts as a single tooth of an imaginary mating generating gear. The wheel is dressed automatically at prescribed stages in the grinding sequence to maintain surface finish and profile accuracy. The geometry and nomenclature of a spiral bevel gear set is shown in Figure 4.

Gleason gear grinding machine setting changes involve first, second, and third order changes. First order changes affect heel and toe position as well as top and flank position. These changes are used in the final positioning of the tooth contact pattern. Second order changes include bias (diagonal movement) changes, profile changes and wheel diameter changes. Third order changes include wheel dresser changes and heel and toe length changes. There are approximately fourteen machine settings that are used by the machine operator in first order changes that affect the shape and position of the gear tooth pattern. Second and third order changes require a calculation of values, using formulas provided by the Gleason Works, by a gear engineer who is consulted prior to making second or third order changes.

When a new bevel gear set is to be produced in quantity, it is first necessary to "develop" the pair -- that is, to determine the desired location and shape of the tooth contact in the Gleason test machine that will provide a satisfactory full and uniform load contact pattern when run in the production gearbox at the power and speed expected in service. This is currently accomplished by a trial and error process. The gear teeth are first semi-finish cut to size on a Gleason bevel gear generator (See Figure 5). The gear member of the pair is then set up in a Gleason bevel gear grinder (Figure 2) to the calculated but unconfirmed machine settings provided by a Gleason gear summary.

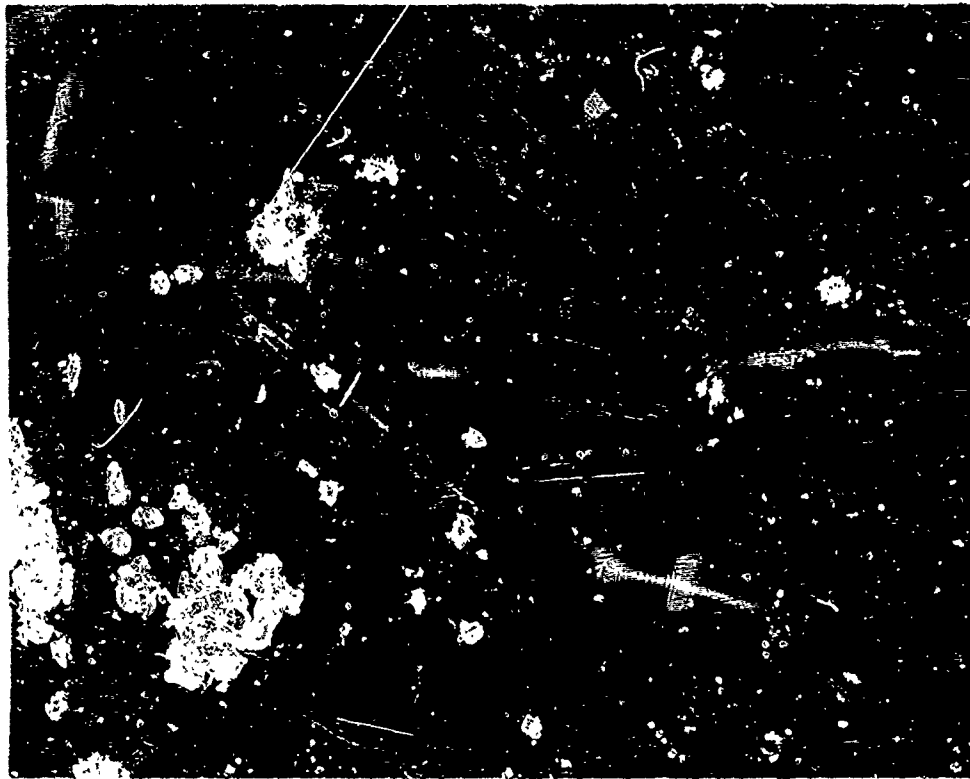

Figure 2. Gleason Bevel Gear Grinder

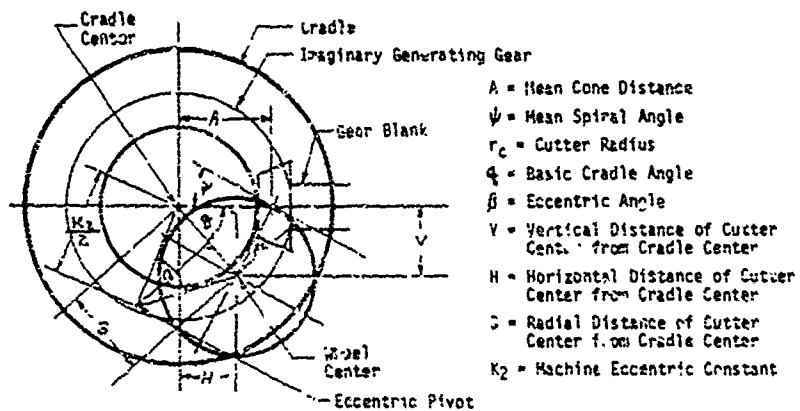

Figure 3. Grinding Machine Geometry



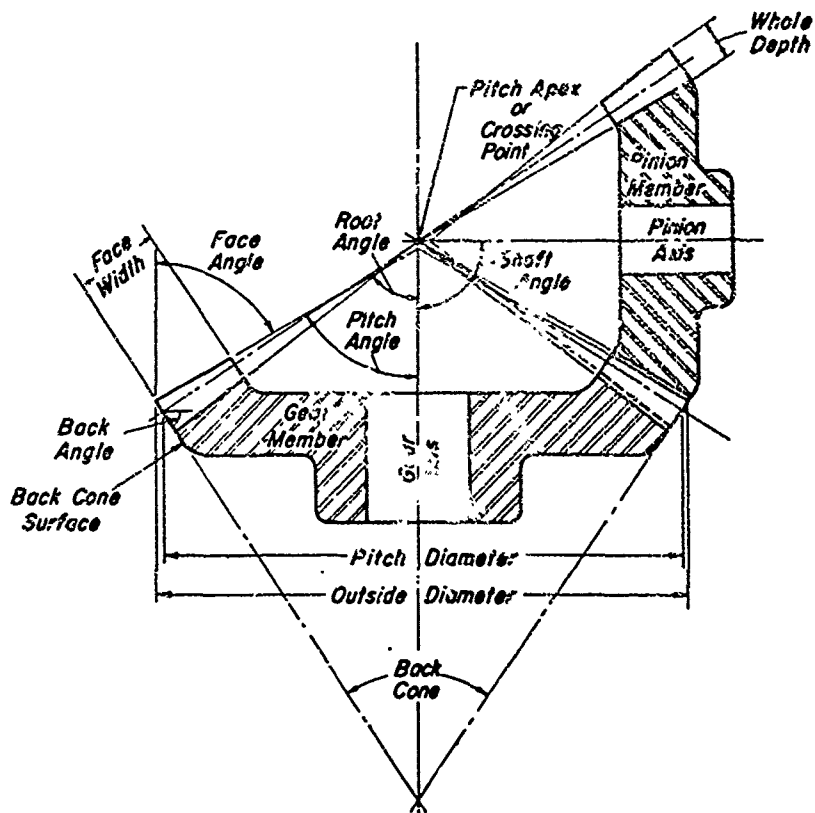

Figure 4. Bevel Gear Nomenclature

This summary consists of approximately thirty machine settings for each side of the tooth. The gear member is ground "spread blade" (both concave and convex sides ground at the same time). The pinion member is set up and ground in the grinding machine to the unconfirmed pinion settings indicated on the summary. The pinion is usually ground "single side" so that a separate set up is required for both the concave and the convex side.

After the gears are ground, they are installed in a Gleason universal test machine (Figure 1) that is set up using precision gage blocks or set up gages to the theoretical gear mounting distance. Using precision work holding equipment, the gear and pinion are mounted in the same relative position to each other as they will be in when run in the actual transmission gearbox. The test machine also allows calibrated adjustments along the gear cone axis, along the pinion cone axis, and in the vertical offset direction.

The gear and pinion are rolled together in the test machine at a pre-determined light brake load (approximately 100 in-lbs of torque) applied



Figure 5. Gleason Bevel Gear Generator

through the pinion spindle. Prior to running, the gear and pinion teeth are painted with a gear marking compound (similar to jeweler's rouge) that produces a rolling contact pattern on the gear and pinion flanks due to the surface contact between the mating teeth and wearing away of the marking compound. Typical contact patterns are shown in Figure 6.

The gears ground to the undeveloped summary settings are then installed in a test gearbox and run under a spectrum of load and speed. The observed composite gear contact patterns are a final indication of the acceptability of the manufactured tooth profile shape.

If the tooth profile contact does not meet the desired shape location and percentage of contact required by the application, the gears are disassembled for regrinding. The usual practice is to regrind, or develop, only the pinion member because it takes less machining time (due to fewer teeth), and because of the Gleason system convention for single side grinding of the pinion. At this point a gear engineer conducts an analyses of the dynamic load pattern, evaluates the Gleason test machine no-load contact patterns, and makes a judgment as to what changes are required on the pinion tooth to improve the dynamic load pattern. To assist the gear engineer in determining what move or

### MASTER PATTERN TAPE RECORD











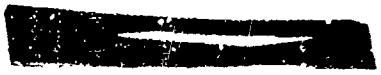
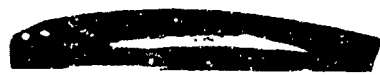

APR 16 1980 MASTER GEAR T - _____ S/N = _____ MASTER GEAR B/L _____ CENTRAL BEARING - DRIVE 	ACTUAL TOTAL B/L _____ MASTER PINION 1 - _____ S/N _____ MASTER PINION B/L _____ 
CENTRAL BEARING - COAST 	
V ONLY TOE  V = <u>+ .005</u>	 ACTUAL V = <u>+ .004</u>
V ONLY HEEL  V = <u>- .019</u> H = _____	 ACTUAL V = <u>- .019</u> ACTUAL H = _____
V & H TOE CHECK  V = <u>+ .005</u> H = <u>- .014</u>	 ACTUAL V = <u>+ .005</u> ACTUAL H = <u>- .014</u>
V & H HEEL CHECK  V = <u>- .025</u> H = <u>+ .008</u>	 ACTUAL V = <u>- .025</u> ACTUAL H = <u>+ .008</u>
PROFILE  V = <u>.000</u> H = <u>+ .005</u> ACTUAL V = <u>.000</u> ACTUAL H = <u>+ .005</u>	PROFILE  V = <u>.000</u> H = <u>- .025</u> ACTUAL V = <u>.001</u> ACTUAL H = <u>- .025</u>

Figure 6. Typical Gear Contact Pattern

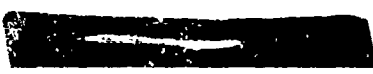
correction to the Gleason grinding machine set up is most appropriate, the pinion cone axis and the vertical offset in the test machine is adjusted to change the pattern size and location. These adjustments provide an indication to the gear engineer as to what grinding machine setting will be most effective in changing the pattern. In most cases it takes a combination of two or more moves to correct a pattern, and more than one combination may produce similar results, but always, one combination is more appropriate.

The pinion is reground to the new adjusted settings and the testing process repeated. The number of iterations necessary to obtain a satisfactory gear profile depends upon the skill and experience of the test machine operator or the gear engineers. This judgment process is probably the weakest link in gear tooth pattern development, even with experienced machine operators.

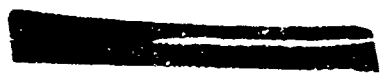
Once the development is complete, several sets of control gears are made that duplicate the newly developed pair as precisely as possible. These master control gears are used to inspect the production gears. They are run in the Gleason test machine against each mating gear subsequently produced by the final machine settings to visually inspect the contact patterns against those obtained for the developed master gear pair in order to assure maintenance of uniform quality.

The production process control for spiral bevel gears is, in effect, a miniature development process except that the changes required to keep a drifting contact pattern situation under control are more subtle and involve the visual comparison of a production gear pattern with the established master gear pattern and the necessary corrective changes to keep the two in agreement.

The quality control process described above has certain inherent disadvantages. First the acceptance or rejection of a production gear is based upon a visual comparison of tooth contact patterns. Not only the size of the pattern, but its shape and location, are significant. Acceptance limits for these features are difficult to define quantitatively, therefore the accept/reject decision becomes a subjective one and is subject to the human frailties of the operator. Second, the size, shape and location requirements of the tooth contact pattern are peculiar to each gear mesh and gearbox mounting and no particular area, shape, or position can be considered universally ideal. Third, since the tooth contact is localized and tested under a very light load, it is necessary to determine not only that satisfactory contact patterns are obtained when the gears are mounted in their equivalent running position in the gear tester but to what extent this pattern is changed by axial and radial movements of the pinion axis, with respect to the gear axis, that would move the pattern to the limits of the tooth contact zone. This is known throughout the industry as the V and H check. By comparing patterns at these extreme V and H settings, a cursory check on lengthwise and profile curvatures is maintained. It should be noted that, in some cases, it is impossible to extend the contact to the extreme corners of the tooth by this method.

It is apparent from the above discussion that there is a definite need for a more definitive and objective way of determining whether a bevel gear profile is acceptable and what specific changes are necessary in the grinding machine settings to most efficiently bring an errant pattern situation under control

before it gets too far out of hand. It is important to control the tooth profile on highly loaded gears to within rather narrow limits. A tooth profile with excessive profile error will result in concentrations of load that could cause scuffing, pitting, or even tooth breakage.

The automated inspection and precision grinding procedures developed in this program, utilizing an automated multi-axis coordinate measuring machine, will satisfy this need for quantitative evaluation of a spiral bevel gear tooth profile in physical and measurable geometric terms without resorting to subjective visual comparisons of tooth contact patterns.

## DEVELOPMENT OF A FINAL INSPECTION METHOD

### Bevel Gear Selection

The production spiral bevel gear set selected for study in this program is one of the primary drive gears of the BLACK HAWK helicopter shown in Figure 7. The BLACK HAWK is the Army's advanced twin engine tactical transport helicopter manufactured by Sikorsky to perform the missions of assault, resupply, medical evacuation, command and control, and tactical positioning of reserves. Two GE-T700 turboshaft engines deliver 1,560 horsepower each to the BLACK HAWK drive system. The main transmission, shown in Figure 8, consists of a main module, two interchangeable input modules, and two interchangeable accessory modules. The main transmission transmits 2,828 maximum continuous horsepower with an input speed of 20,900 RPM.



Figure 7. BLACK HAWK Utility Helicopter

The main module gear set selected for evaluation is shown highlighted in Figure 9 and in close up in Figure 10. This primary drive spiral bevel set has a speed reduction ratio of 4.76 and rotates at an input speed of 5,748 RPM. It transmits 1,414 horsepower each on a continuous basis and has a single engine capacity of 1,560 HP.

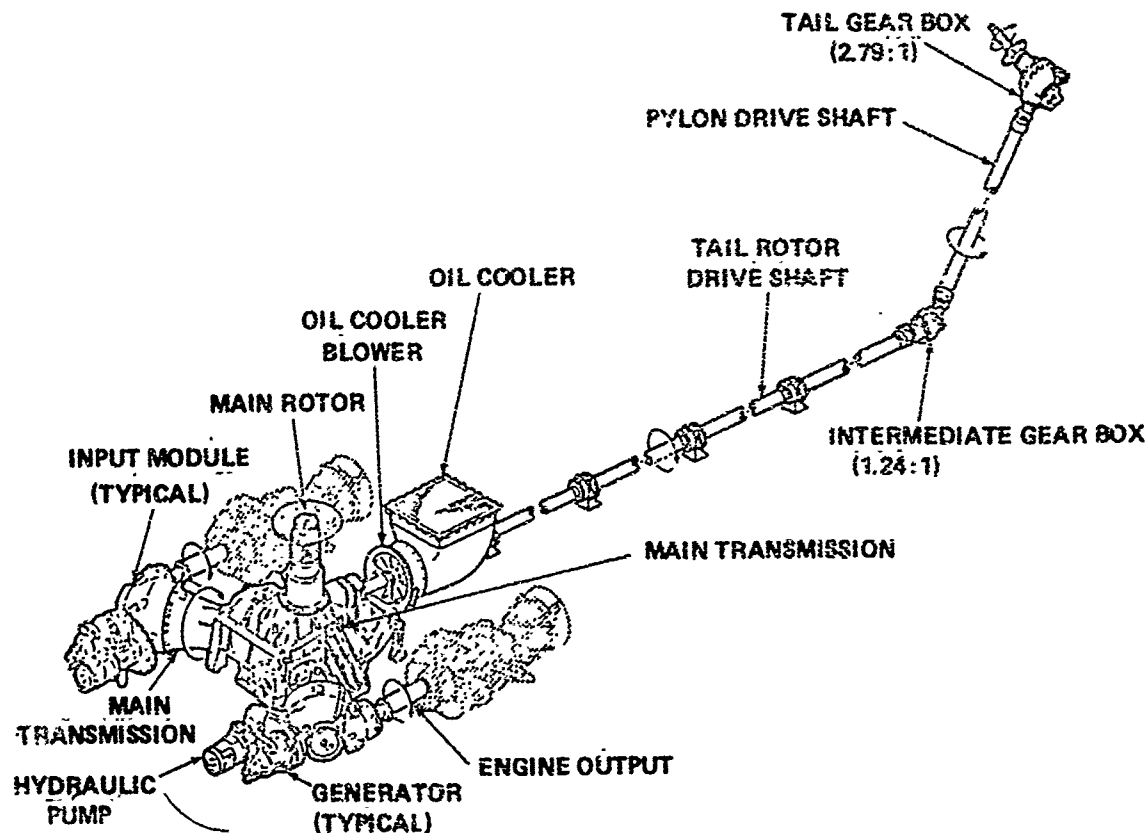

Figure 8. BLACK HAWK Drive Train

This gear set was chosen for this study because of its sensitivity to small changes in grinding machine setting which led, at one time, to excessive rejection rates due to the presence of hard contact lines and scoring when operated in the gearbox during ATP (Acceptance Test Plan) testing. The solution to this problem was:

- Tighter tolerance limits for the evaluation of the contact pattern in the Gleason test machine.
- Restriction of grinding machine setting changes used to adjust pattern.
- Improving shimming practices during installation.

The lessons learned during the investigation and correction of these problems were:

- All master gears are not the same. Variations do exist in master gears that are not apparent when checking a production gear.

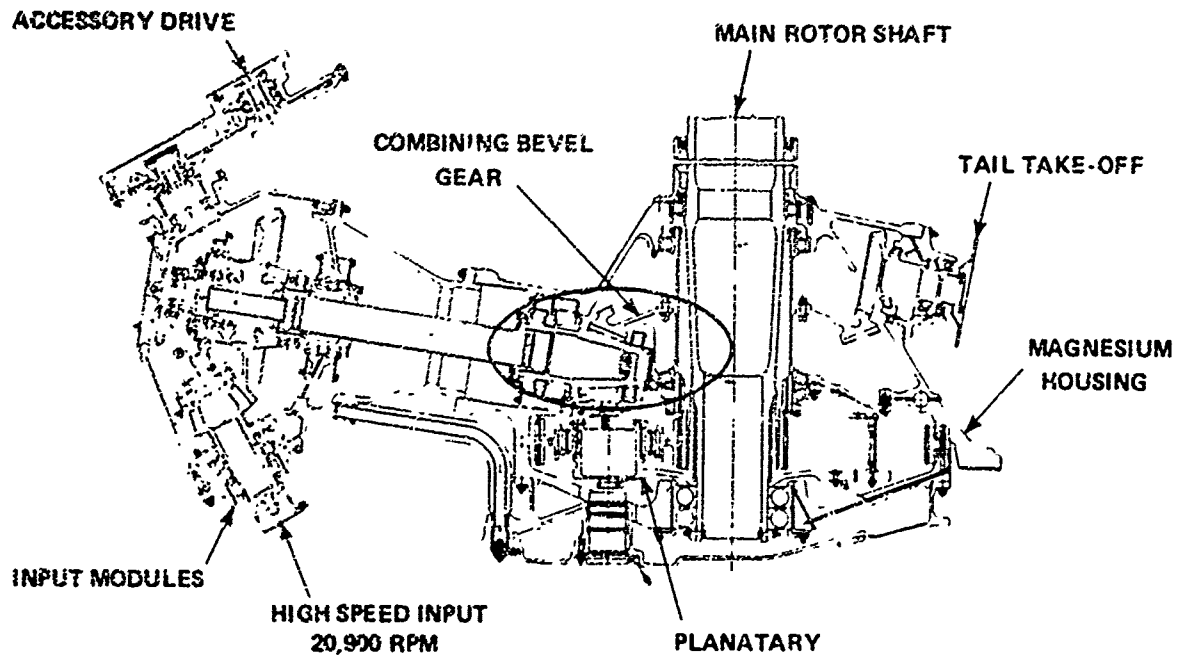

Figure 9. BLACK HAWK Main Gearbox



Figure 10. Selected Bevel Gear Set



- Rolling contact patterns are affected by
  - wear of master gear profile.
  - marking compound application.
  - the braking load used during the rolling test.
- Highly stressed bevel gears can be extremely sensitive to pattern variations.

### Test Gear Specimens

The gear test specimens for this program are shown in Figures 11 and 12. These specimens duplicate the actual production gear set shown in Figure 10 in the essential details with respect to gear tooth geometry and fixturing dimensions. Non-essential details such as splines, threads, case hardnesses, etc., have been eliminated. The basic design features of this gear set are shown below.

	<u>Pinion</u>		<u>Gear</u>
No. of Teeth	17		81
Dia. Pitch		4.108	
Pressure Angle		20°	
Shaft Angle		81.85°	
Spiral Angle		25°	
Face Width		2.56	
RPM	5748		1206
HP		1516	

To accomplish the tasks in the time allotted in the program schedule, fabrication of the gear test specimens needed for the sensitivity study of Phase II was initiated in this phase. Machining of the test gear blanks was taken up to the point of final grinding of the gear teeth. Final grinding of the gear teeth with deviations from the baseline settings was accomplished in the Phase II development of an in-process inspection technique.

### Universal Multi-Axis Coordinate Measuring Machine

When checking the topology of a three dimensionally curved surface, such as a spiral bevel gear tooth flank, using computer-controlled multi-axis measuring machines, the following requirements must be met:

- The nominal or reference surface must be expressible either as a mathematical model or as a matrix of discrete coordinate values representing the desired surface.
- The actual surface must be measurable with precision accuracy in a reasonable period of time.
- Quantitative comparison of the actual and nominal tooth surfaces is possible.



SPIRAL BEVEL GEAR DATA	
NUMBER OF TEETH	61
FACE ANGLE	20°40'
SPINDLE ANGLE	25°45'
FACE WIDTH	2.560
DIAGONAL PITCH	4.200
PITCH DIAMETER	19.249
ADDENDUM	.329
DEDEMENTUM	.133
PITCH ANGLE	70°27'
ADDENDUM ANGLE	60°00'
DEDEMENTUM ANGLE	74°02'
FACE ANGLE OF BLANK	21°06'
ROOT ANGLE	60°45'
OUTSIDE DIAMETER	19.323
PITCH CONE RADIUS TO CENTER	2.315
MOUNTING DISTANCE	4.762
DIRECTION OF ROTATION	CCW
CIRCULAR TOOTH THICKNESS	2.10
DRILLING POSITIONAL TOLERANCE	0.005
ROUND OF SPINDLE	0.030
SECTION SYMBOL	169.7200

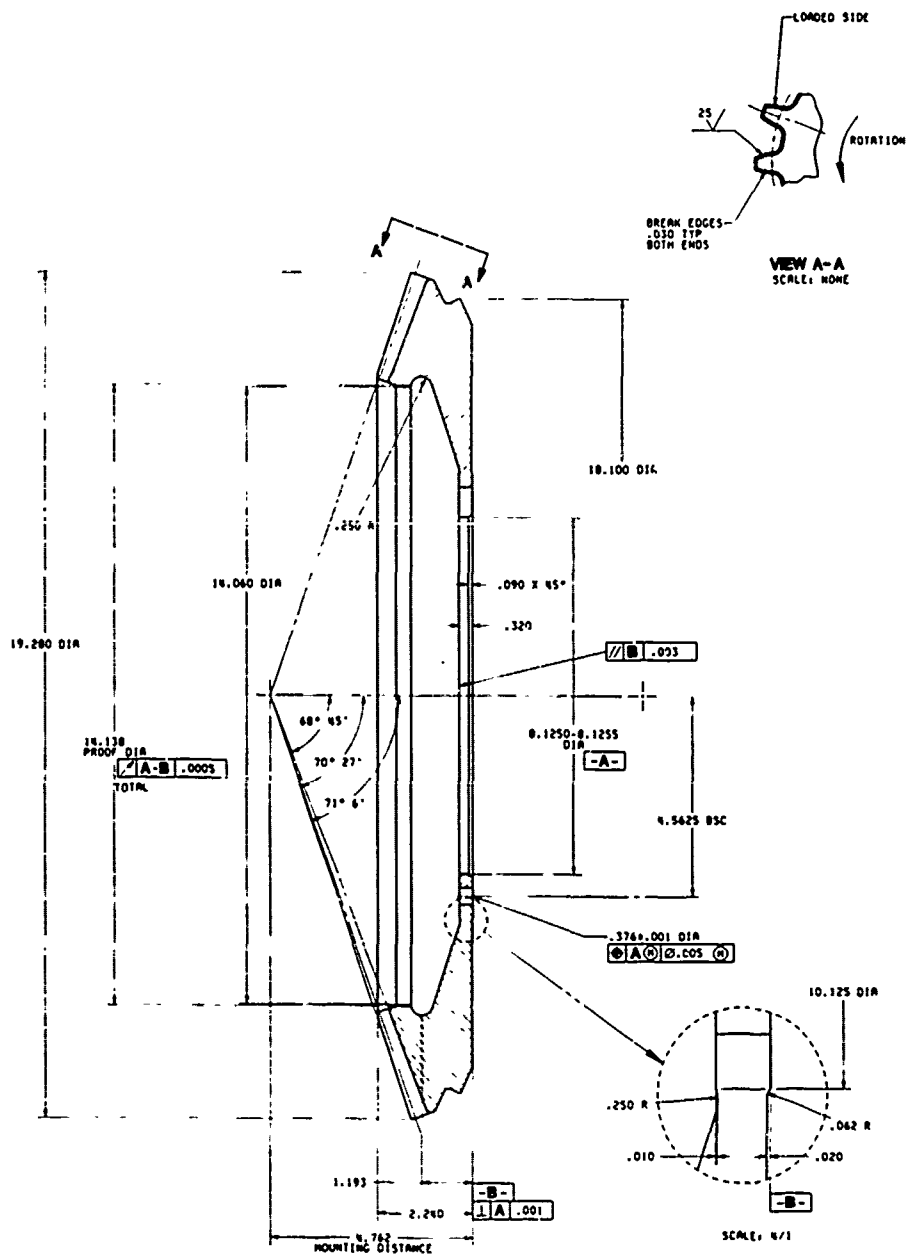

Figure 12. Gear Test Specimen

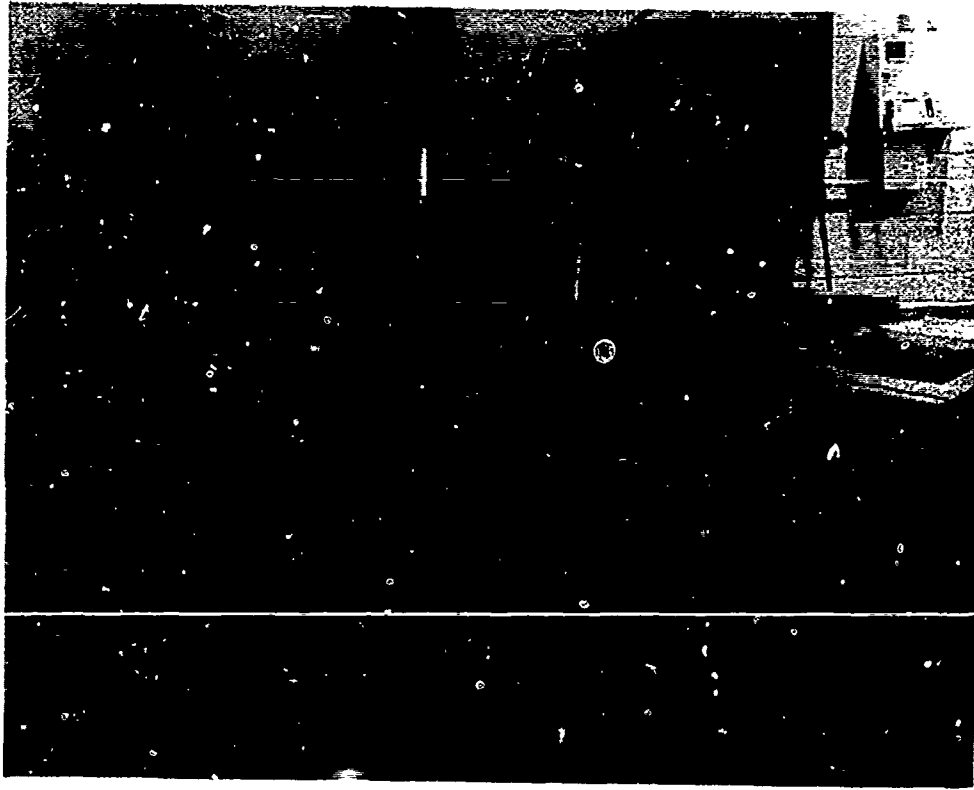

Figure 13. Zeiss UMM 500 Measuring Machine

orthogonal directions. This machine, in conjunction with a sophisticated 3D software package, provides a distinct and quantitative means of measuring and mapping three dimensional surface contours. In order to accommodate the complex surface of the spiral bevel gear tooth, a precision indexing table, shown in Figure 14, was added as the 4th axis in gear measuring programs. The computer program packet for gear measurement permits the determination of the face profile coordinates of spiral bevel teeth at an almost unlimited number of probe points on the tooth surface and a point by point comparison with stored nominal reference values.

The UMM-500 was delivered with the model HP 9825 desk computer. The software package purchased with the measuring machine included the UMESS program; which is a universal measuring program applied to the dimensional measurement of planes, spheres, cylinders, and cones; and the RAM2 which is a special purpose spiral bevel gear measurement program with misalignment compensation on the rotary table.

Prior to the initiation of Phase II, it was discovered that the Gleason Works was using a HP 9836 computer system with their Zeiss machine, and the software that they had developed, and were supplying to Sikorsky, for use in Phase II was not compatible with the installed Sikorsky system. This discovery

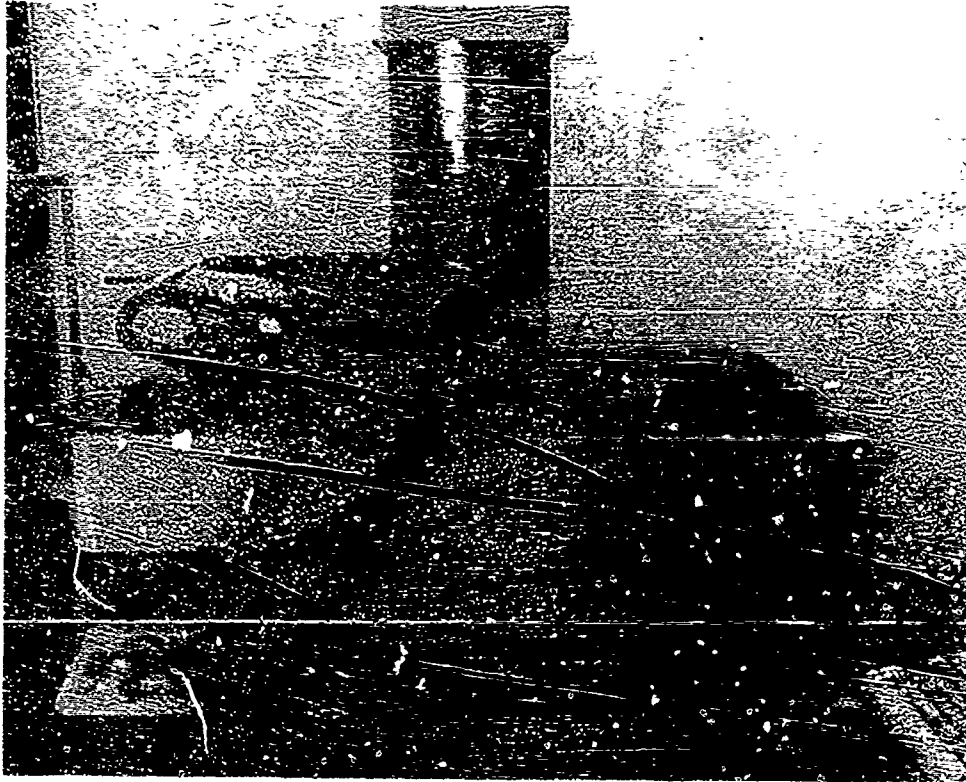

Figure 14. Gear Member on Indexing Table

necessitated a retrofit of the HP 9825 computer system to convert it to the HP 9836 system. In this new system, the COMET program replaces the UMESS program. The Gleason-developed program originally called the G-MET program performs the spiral bevel gear measurements previously handled by the RAM2 program, and additionally contains the corrective feature which calculates the necessary grinding machine setting changes required to correct the profile.

The final automatic measuring and data processing system developed, consists of several instruments (Figure 13), which are controlled by a central computer. The system shown includes Hewlett Packard 9836 Desk Top Computer, Zeiss UMM500 Universal Measuring Machine, Hewlett Packard 9865A Cassette Memory, Hewlett Packard 9862A X-Y Plotter and Impact Line Printer. During measurement, information is constantly being transferred between the central processor and the various peripherals (measuring machine and plotter) working continuously. Both of these devices are permitted only very short, process-dependent operating pauses, in particular a 1-second stabilization period for the measuring machine after contact. During the pause after probing, the computer prepares the information required for the next measuring point (coordinate transformations, choice of contacting direction and determination of the probe approach path) and processes the measurement values of the previous point, initiating plotting and printing procedures.

This Zeiss UMM500 measurement system has an even broader capability that further enhances its use in the manufacture and inspection of spiral bevel gears. In addition to measuring the surface topology of the tooth surface, it can also measure:

- Tooth to tooth spacing errors (pitch variations)
- Accumulated spacing errors (index variations)
- Chordal tooth thicknesses
- Face angle
- Root angle
- Back and front angles
- Whole depth
- Face width
- Root and fillet radii

All of the above values can be programmed to be automatically measured and recorded on a hard copy print out.

#### Master Gear Data

As was previously discussed, the tooth profile of the master control gear represents the desired tooth contour produced by the final-developed bevel gear grinding machine settings and is the reference gear to which all production gears are ultimately compared. In the Sikorsky production system, there are three levels of master control gears. T015s are Reference Master Control gears which are used only to check the Inspection Control Master Gears (T84s). The T84s are used in turn only to check the Working Control Master Gears (T199s) which are used for the in-process and final inspection of production gears. The master control gears used in this study are the highest level or T015s.

Before proceeding to the coordinate measurement process, the master control gears for the selected gear set were set up in the Gleason test machine, run together, and contact patterns recorded for the following set ups:

- Standard center position
- Toe position
- Heel position

The taped patterns were taken at four tooth positions (approximately evenly spaced) on the pinion and at eight tooth positions on the gear. The results of these measurements are shown in Figures 15 and 16.

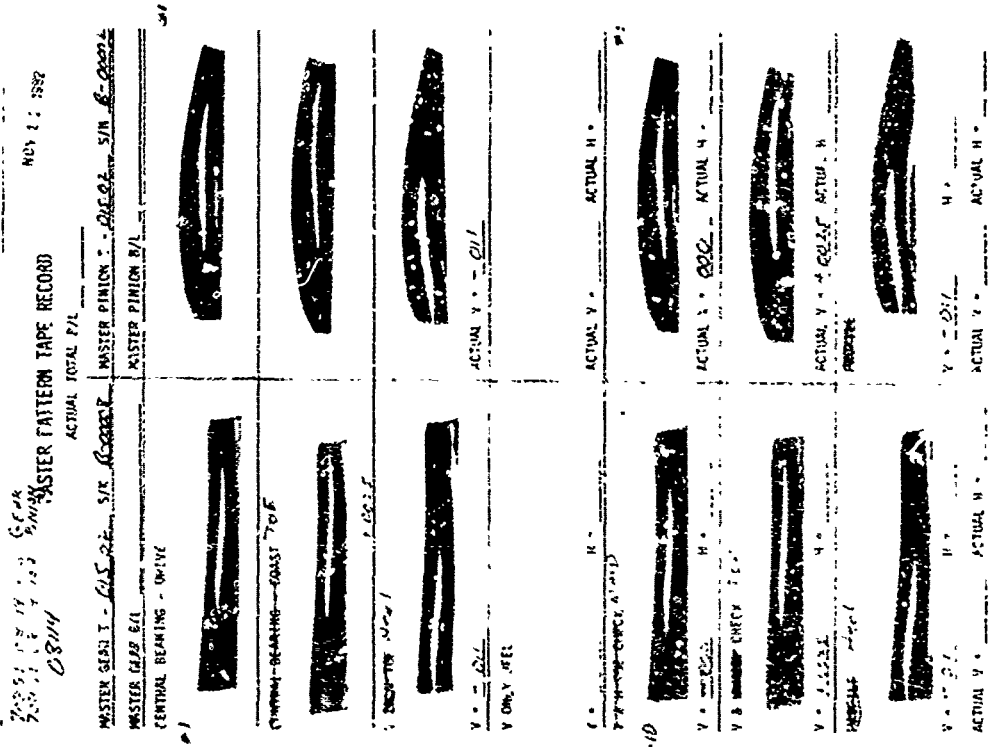
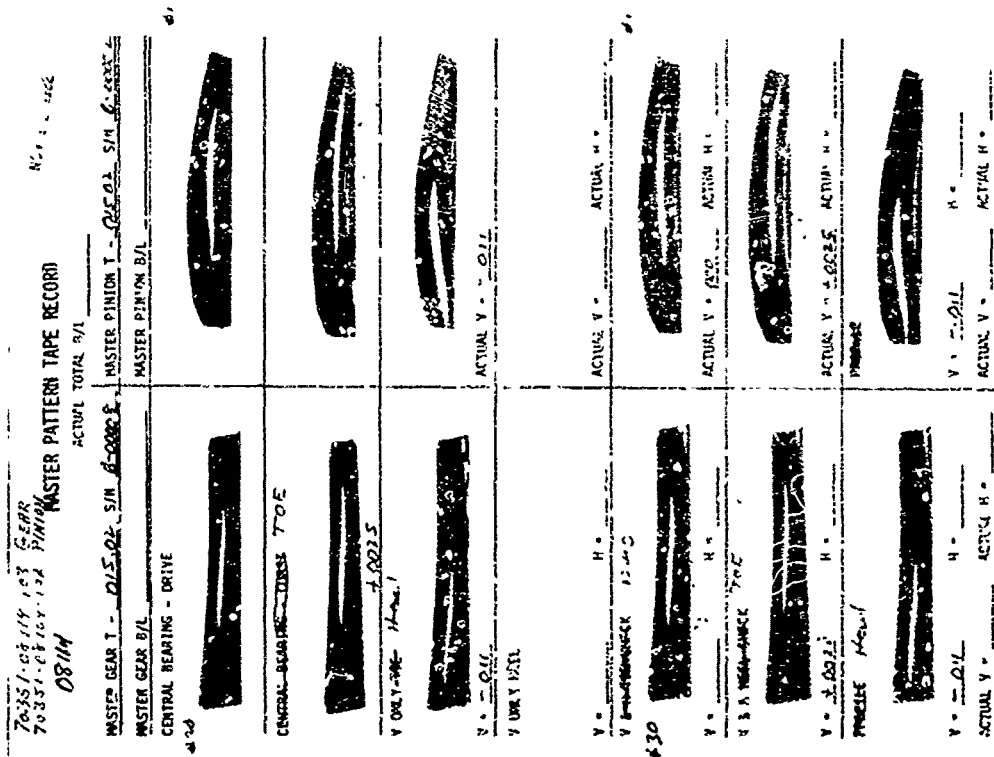

Figure 15. Master Gear Patterns - Pinion

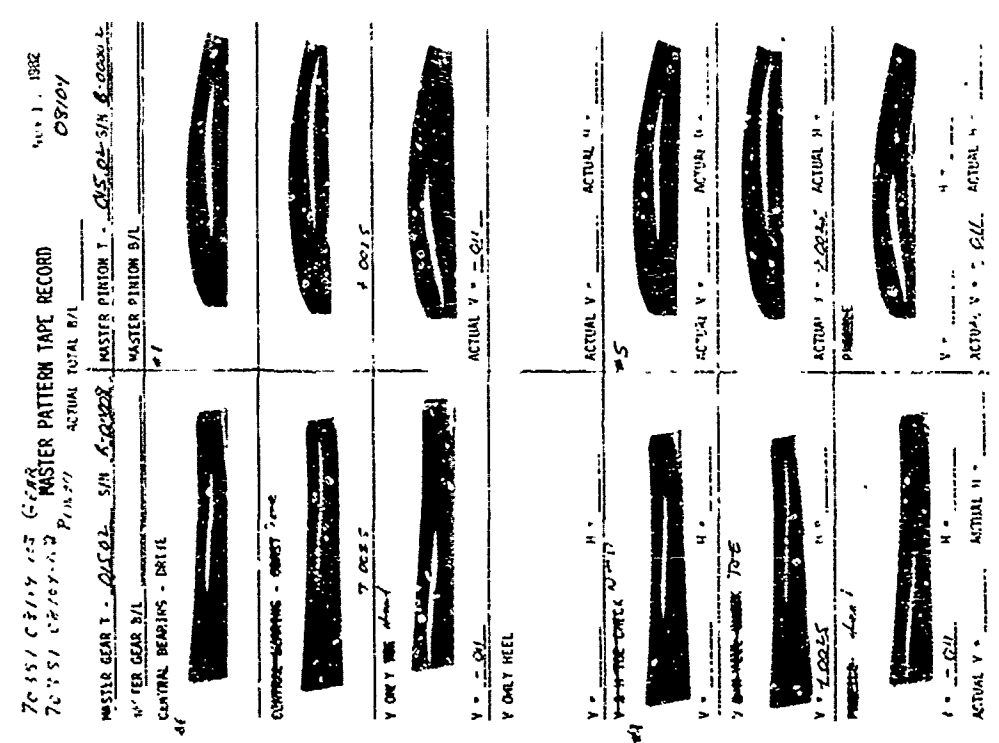
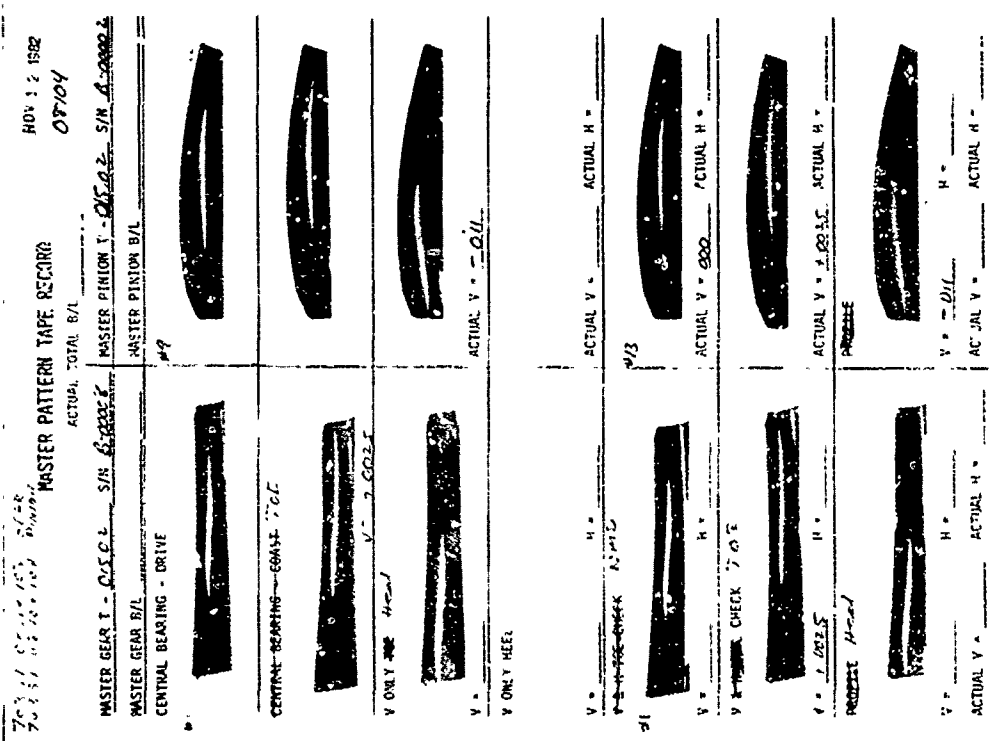

Figure 16. Master Gear Patterns - Gear



## The Final Inspection Measurement Process

The object of any gear measurement system is the comparison of the actual manufactured spiral bevel gear surface topology with an idealized surface, in this case represented by a "hard" master control gear. The computer-controlled measuring machine uses the coordinates of this nominal or reference surface as a guide for probing and comparing the actual gear surface.

### Determination of Nominal Values

The simplest method for determining the nominal points on a gear tooth flank is digitization of the Reference Master Control Gear. The measuring machine is made to probe actual points on the flank of a master gear tooth, as described below, for storage on a magnetic cassette tape. This tape, in effect, becomes the unvarying "soft" master in this improved inspection method. Specialized software permits rapid generation of an evenly distributed point network over the tooth profile after manual probing of the corner points and defining the network density. Care was taken to exclude the edge breaks or corner rounding when establishing the corner points. The vector of the surface normal at each network point is determined mathematically from several automatically probed points in the near vicinity of the specified point. (See Figure 16.) These normalized values are stored on the tape along with the coordinate values. A network of 45 points (a 9 by 5 matrix) was chosen for this study because it was felt that this size grid would provide an adequate map of the tooth surface without resorting to interpolation. Finer or coarser grids are, of course, possible.

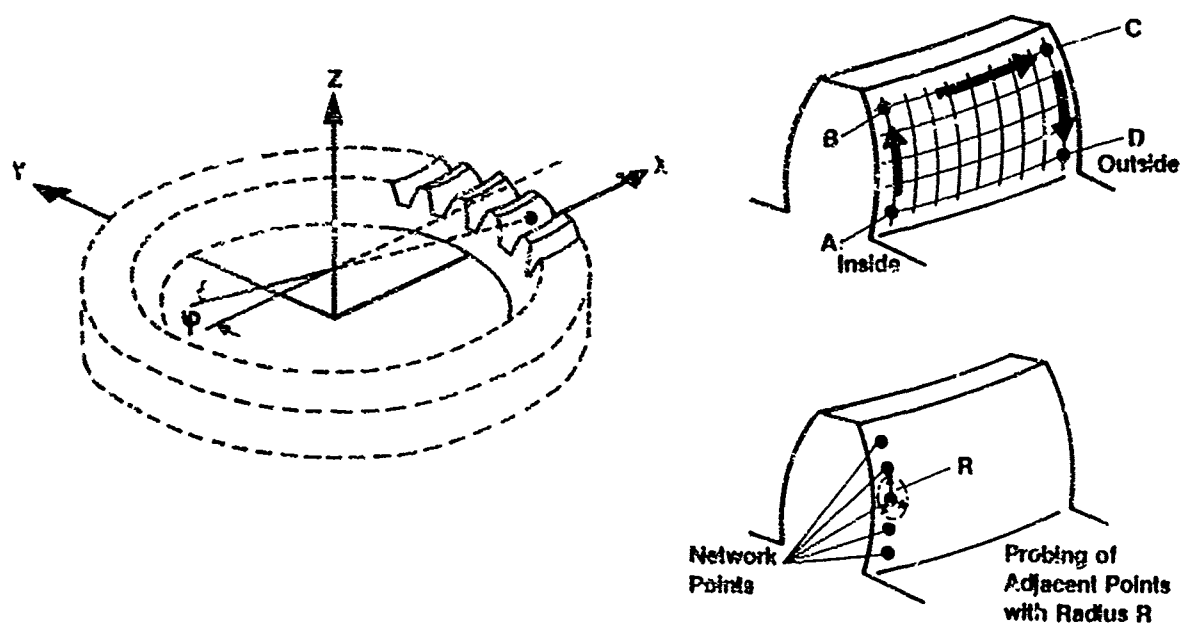

Figure 17. Generation of Network Points

Even though spiral bevel gears possess a high degree of geometric complexity, it is feasible to expect that the nominal surface can be also generated numerically by computer simulation of the manufacturing process. This, in fact, was accomplished by the Gleason Works who provided assistance to Sikorsky Aircraft in this effort. Gleason provided the software, that converts final grinding machine settings, as reflected on a Gleason Grinding Summary, into profile coordinate points which are stored into the UMM500 computer as nominal values. This method permits more freedom in the choice of the form and density of the point network and provides a more theoretical baseline than the measured master gear values, which themselves are subject to manufacturing errors. An evaluation of both methods was made in this program by direct comparison of the nominal values, for a 45 point network, calculated by digitization of the T015 master gear on the UMM500 and by mathematical simulation of the tooth surface accomplished by the Gleason G-Age Program.

### The Measurement Process

The final inspection process consisted of setting up the gear in the Zeiss machine and automatically probing the surface at the 45 network point locations. To accomplish this, the gear was mounted on the coordinate measuring machine indexing table with its axis parallel to the Z axis of the machine (see Figures 14 and 18), care being taken not to deform it while clamping. Part alignment was achieved by bringing the probe into contact at a series of points on a reference diameter to establish the location of the Z axis of the gear in relation to the machine axis. The reference coordinate system for the nominal data for the bevel gear was then located along the gear axis. Any desired zero point can be selected along this axis. In order to determine the angle of rotation of the gear's polar coordinate system relative to the machine's coordinate system, a known point on the tooth flank was contacted and the deviation of this point from nominal set to zero.

When measuring, the compound curved surfaces of spiral bevel gears, the "continuous probing" mode of the Zeiss system was found to be particularly beneficial. The machine followed the contour of the part in a predetermined direction in the same manner as the follower head on a 3-D copy mill. The automatic positioning control that is actuated at probe contact scanned the free axis of the machine until the inductive measuring system in the probe head was brought to its null point. The moment this condition is achieved all three machine coordinates are automatically transmitted to the computer, therefore, the probe can be locked in the X axis and be made to traverse to predetermined locations in the Y axis, while automatically following contour changes of the part in the Z axis, and the machine will remain at a preselected X-Y location until the probe has been nulled in the Z direction and the position information transmitted to the computer. It then proceeds to the next X-Y location.

The tooth flanks were measured in CNC mode. Nominal points on the network were loaded from the magnetic tape cassette into core memory and transformed into machine coordinates. The computer kept track of the momentary position of the probe and determined the path to the next point. The measured deviations from the nominal surface were determined along the projected surface normals.

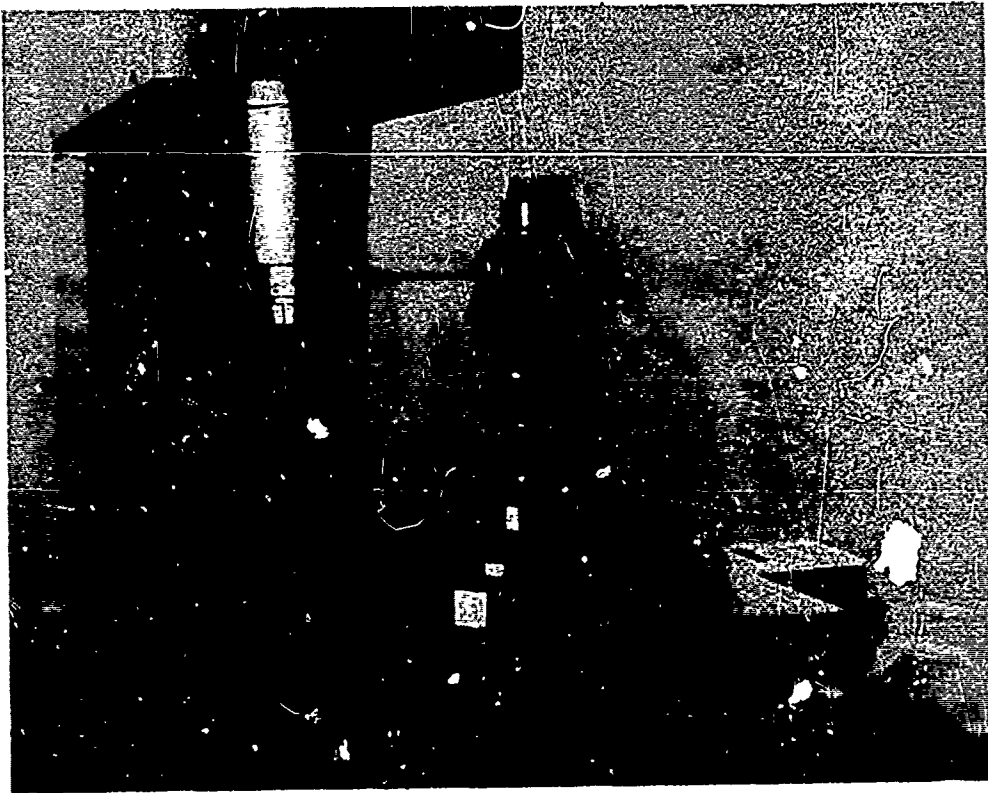

Figure 18. Pinion Set Up in UMM 500

### Measurement Results

In this study a particular tooth on the master pinion was designated as the reference master tooth. The coordinates on the drive side of this particular tooth were measured at the 45 network locations covering the entire working profile of the tooth. These coordinates became the nominal values for the master pinion and were stored in the computer as the reference coordinates. A similar procedure was used to determine the nominal values for the master gear. Using the same set up in the coordinate measuring machine, the tooth profiles of additional teeth on the master pinion and gear were measured and compared with the nominal values. Note, the same teeth on the master pinion and gear for which taped patterns previously recorded in the Gleason gear tester were used in this measurement process.

The results of these measurements are shown in the three-dimensional graphical plots in Figures 19 and 20, and in Tabular form in Tables 1 and 2 for pinion and gear respectively. The digital print out locates each grid point by column and row number. For each grid point, the X, Y and Z coordinate values are listed as well as the x, y, and z deviations from the stored nominal values. The last column in the print out is the deviation in the surface normal dimension and is the value plotted in Figures 19 and 20. The tabulated values are in mm.

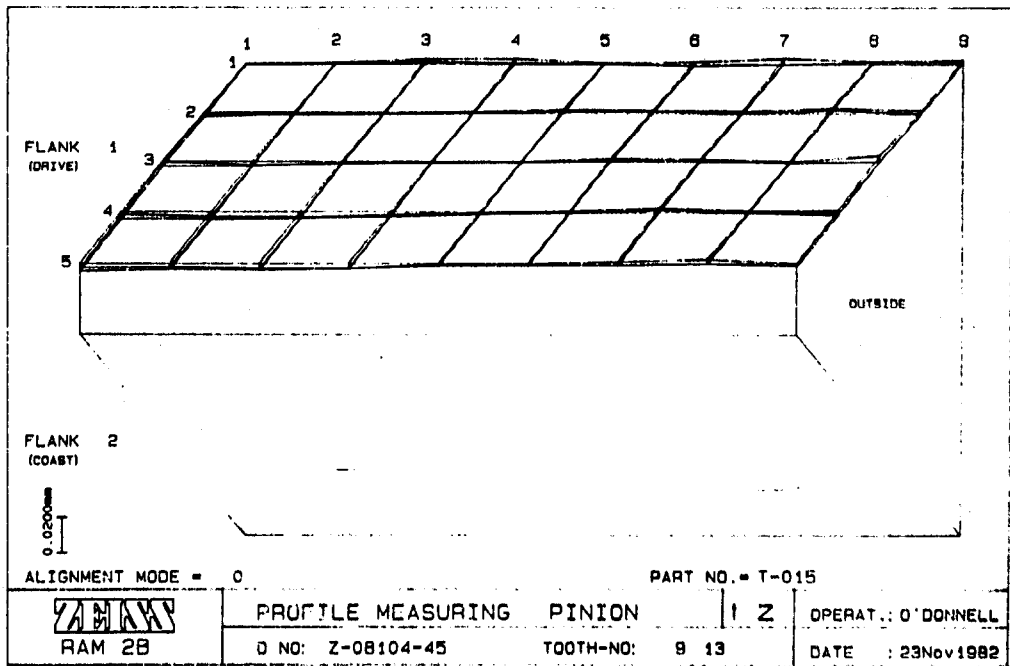
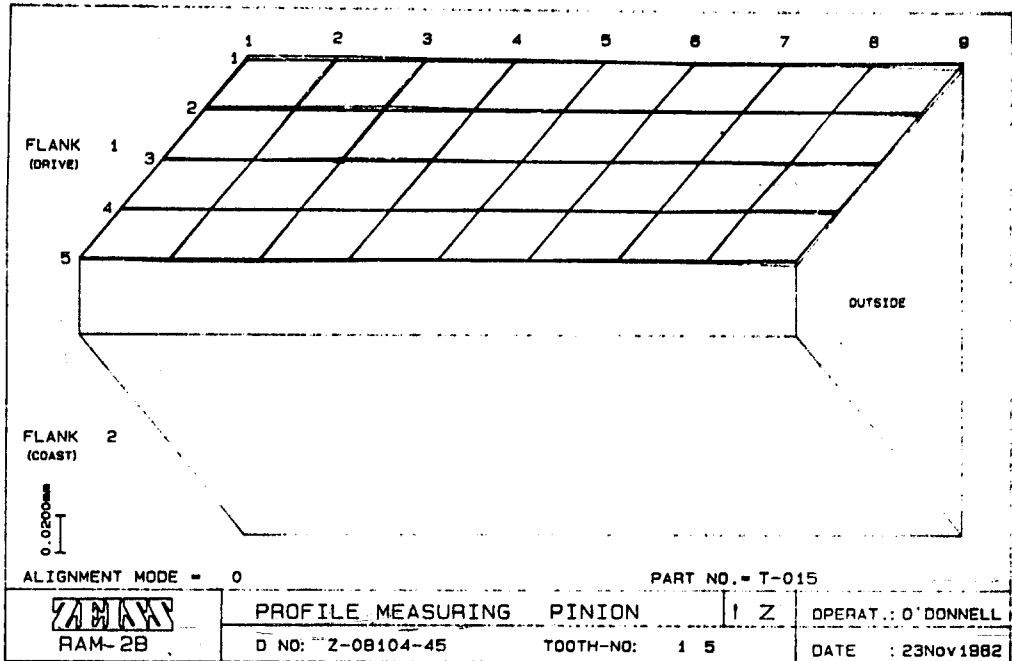

Figure 19. Zeiss Measurements of Master Pinion

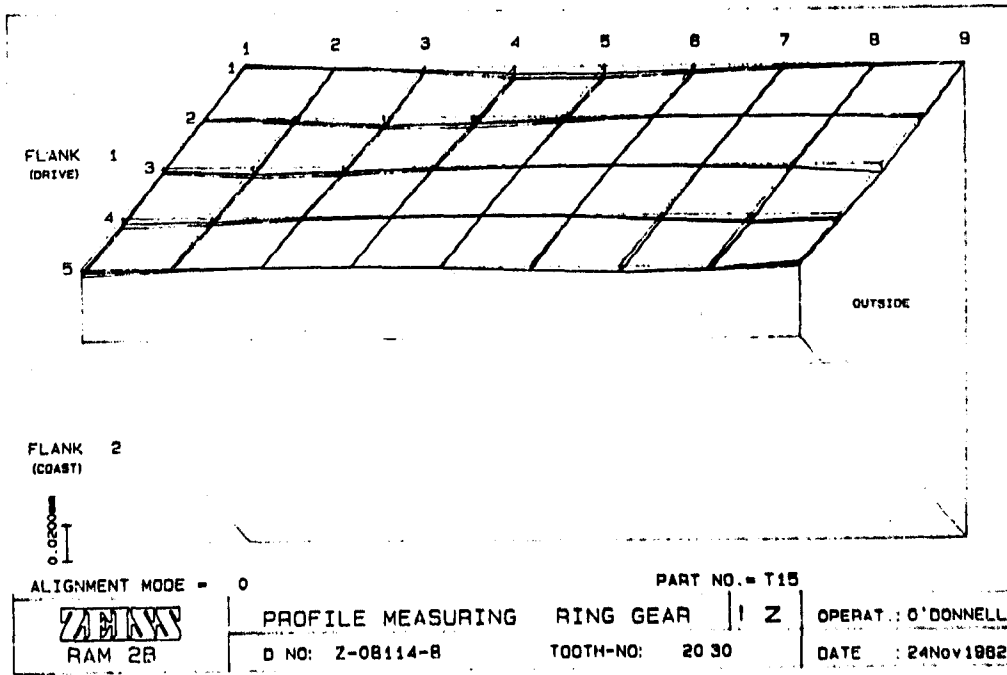
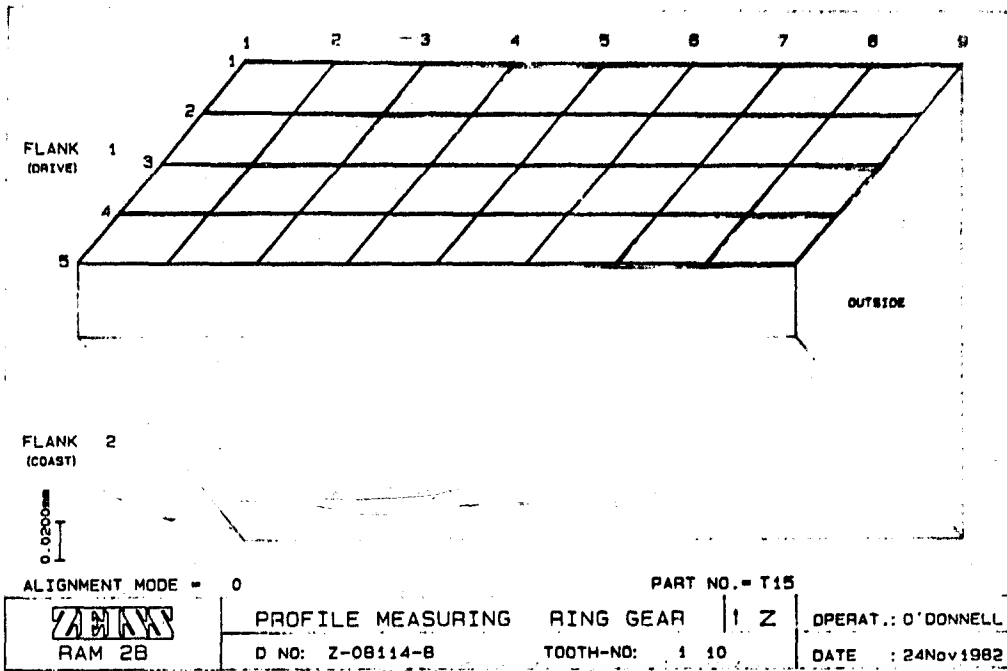

Figure 20. Zeiss Measurements of Master Gear

TABLE 1. ZEISS MEASUREMENTS OF MASTER PINION

```

=====
MEASURE RECORD   ZEISS RAM 23

PINION 08104-45
=====

DRAWING NO      | PART NO | ORDER NO      | SUPPLIER/CUSTOMER | OPERATION
Z-08104-45     | T-015  | NA            | SIKORSKY           | INSP FLANK

OPERATOR        | DATE
O'DONNELL      | 23Nov1982
=====
C | L | X | Y | Z | DX | DY | DZ | EN
=====
ALIGNMENT MODE  0
TOOTH 1         FLANK 1
1 1  37.8475  0.6246  76.7222  0.0000 -0.0007  0.0001  -0.0007
1 2  38.7958  0.3886  76.8361  0.0002 -0.0001  0.0003  0.0000
1 3  39.8687 -0.0003  76.9773  0.0012 -0.0001 -0.0002  0.0002
1 4  40.9568 -0.4978  77.1169  0.0010  0.0003 -0.0000  0.0006
1 5  42.0743 -1.1033  77.2623  0.0006  0.0005  0.0003  0.0007

2 1  39.1630  2.9321  69.2216  0.0004 -0.0003 -0.0002  -0.0003
2 2  40.1865  2.7347  69.3548  0.0005 -0.0001  0.0002  0.0001
2 3  41.3306  2.3827  69.5091  0.0009 -0.0000  0.0001  0.0002
2 4  42.5179  1.9170  69.6708 -0.0003  0.0002  0.0001  0.0001
2 5  43.7239  1.3375  69.8314  0.0001  0.0004 -0.0002  0.0003

3 1  40.2961  5.6532  61.7142  0.0002 -0.0003 -0.0001  -0.0003
3 2  41.3856  5.5065  61.8683  0.0005  0.0000  0.0001  0.0001
3 3  42.6168  5.2076  62.0440  0.0009  0.0003  0.0000  0.0004
3 4  43.8960  4.7860  62.2238  0.0007  0.0002 -0.0000  0.0004
3 5  45.2063  4.2540  62.4042 -0.0001  0.0003  0.0003  0.0003

4 1  41.1635  8.7839  54.2136 -0.0001 -0.0002 -0.0004  -0.0003
4 2  42.3422  8.7047  54.3884  0.0006 -0.0000  0.0006  0.0003
4 3  43.6589  8.4708  54.5811  0.0002 -0.0001 -0.0001  -0.0001
4 4  45.0240  8.1173  54.7784  0.0007 -0.0002 -0.0003  -0.0002
4 5  46.4400  7.6394  54.9754 -0.0002  0.0008 -0.0002  0.0005

5 1  41.7375  12.3184  46.7132  0.0000 -0.0002  0.0002  -0.0001
5 2  42.9710  12.3150  46.9050  0.0012  0.0002  0.0003  0.0003
5 3  44.3695  12.1694  47.1180  0.0003  0.0003 -0.0001  0.0002
5 4  45.8338  11.8926  47.3332 -0.0001  0.0004  0.0000  0.0003
5 5  47.3491  11.4983  47.5481  0.0002  0.0005 -0.0000  0.0004

6 1  41.8922  16.2277  39.2155  0.0001 -0.0006 -0.0001  -0.0006
6 2  43.1926  16.3270  39.4244  0.0008  0.0003  0.0003  0.0004
6 3  44.6727  16.2762  39.6557  0.0005 -0.0002 -0.0001  -0.0003
6 4  46.2238  16.1048  39.8891  0.0004  0.0002 -0.0002  0.0001
6 5  47.8443  15.8048  40.1230  0.0007  0.0000  0.0002  0.0002

7 1  41.5628  20.4878  31.7149  0.0002 -0.0005  0.0001  -0.0004
7 2  42.9199  20.6972  31.9465  0.0004  0.0005  0.0001  0.0004
7 3  44.4672  20.7732  32.1954  0.0003  0.0007 -0.0001  0.0005
7 4  46.1087  20.7159  32.4453  0.0006 -0.0003 -0.0002  -0.0004
7 5  47.8286  20.5417  32.7001  0.0005  0.0007  0.0002  0.0007

8 1  40.6611  25.0574  24.2153 -0.0000 -0.0001 -0.0000  -0.0001
=====

```

TABLE 1. (Cont'd)

C	I	X	Y	Z	DX	DY	DZ	EN
8	2	42.0609	25.3919	24.4671	0.0005	0.0005	0.0003	0.0004
8	3	43.6667	25.6046	24.7341	-0.0003	0.0002	-0.0003	0.0000
8	4	45.3835	25.6964	25.0052	0.0003	0.0008	-0.0001	0.0005
8	5	47.1893	25.6567	25.2774	0.0007	0.0006	-0.0002	0.0003
9	1	39.0643	29.8595	16.7170	-0.0006	0.0003	0.0000	0.0005
9	2	40.5011	30.3445	16.9904	0.0003	0.0007	-0.0002	0.0003
9	3	42.1535	30.7141	17.2747	0.0006	0.0007	0.0002	0.0005
9	4	43.9291	30.9677	17.5638	0.0004	0.0010	-0.0001	0.0007
9	5	45.8174	31.0999	17.8564	0.0005	0.0008	0.0001	0.0006
TOOTH 5 FLANK 1								
1	1	37.8475	0.6272	76.7222	-0.0002	0.0018	0.0002	0.0018
1	2	38.7958	0.3901	76.8361	0.0006	0.0014	-0.0002	0.0014
1	3	39.8697	0.0007	76.9773	0.0003	0.0012	-0.0000	0.0011
1	4	40.9558	-0.4985	77.1169	0.0006	-0.0003	0.0001	-0.0000
1	5	42.0743	-1.1039	77.2623	0.0005	0.0000	0.0001	0.0003
2	1	39.1630	2.9346	69.2216	-0.0001	0.0021	-0.0000	0.0020
2	2	40.1865	2.7365	69.3548	0.0005	0.0017	0.0001	0.0017
2	3	41.3306	2.3828	69.5091	0.0004	0.0002	0.0000	0.0003
2	4	42.5179	1.9166	69.6708	0.0007	-0.0004	-0.0002	-0.0002
2	5	43.7239	1.3358	69.8314	0.0008	-0.0017	0.0000	-0.0011
3	1	40.2961	5.6548	61.7142	-0.0004	0.0014	-0.0003	0.0012
3	2	41.3856	5.5688	61.8683	0.0002	0.0024	0.0002	0.0023
3	3	42.6168	5.2110	62.0440	0.0005	0.0017	-0.0000	0.0017
3	4	43.8960	4.7858	62.2238	-0.0001	0.0001	0.0001	0.0002
3	5	45.2063	4.2524	62.4042	0.0004	-0.0015	0.0002	-0.0011
4	1	41.1635	8.7853	54.2136	-0.0000	0.0011	-0.0001	0.0010
4	2	42.3422	8.7058	54.3884	0.0003	0.0011	0.0004	0.0011
4	3	43.6589	8.4724	54.5811	0.0002	0.0015	-0.0003	0.0013
4	4	45.0240	8.1177	54.7784	0.0001	0.0003	0.0000	0.0003
4	5	46.4400	7.6383	54.9754	0.0005	-0.0005	-0.0002	-0.0004
5	1	41.7375	12.3193	46.7132	0.0000	0.0006	-0.0004	0.0004
5	2	42.9710	12.3155	46.9050	0.0003	0.0010	-0.0004	0.0007
5	3	44.3695	12.1691	47.1180	0.0002	-0.0000	-0.0001	-0.0000
5	4	45.8338	11.8930	47.3332	-0.0001	0.0008	-0.0000	0.0007
5	5	47.3491	11.4983	47.5481	0.0004	0.0004	0.0001	0.0005
6	1	41.8922	16.2271	39.2155	0.0005	-0.0011	-0.0001	-0.0011
6	2	43.1926	16.3276	39.4244	0.0004	0.0011	-0.0001	0.0009
6	3	44.6727	16.2769	39.6557	0.0007	0.0004	0.0000	0.0003
6	4	46.2238	16.1046	39.8891	0.0005	-0.0003	0.0002	-0.0001
6	5	47.8443	15.8046	40.1230	0.0004	0.0001	-0.0001	0.0001
7	1	41.5628	20.4869	31.7149	0.0007	-0.0012	0.0001	-0.0012
7	2	42.9199	20.6965	31.9465	0.0009	-0.0002	0.0003	-0.0002
7	3	44.4672	20.7732	32.1954	0.0002	0.0006	-0.0001	0.0004

TABLE 1. (Cont'd)

C	I	L	X	Y	Z	DX	DY	DZ	EN
7	4		46.1087	20.7158	32.4453	0.0003	-0.0005	-0.0001	-0.0005
7	5		47.8286	20.5404	32.7001	0.0010	-0.0006	0.0001	-0.0004
8	1		40.6611	25.0555	24.2153	0.0013	-0.0014	0.0001	-0.0015
8	2		42.0609	25.3923	24.4671	0.0003	0.0008	0.0003	0.0007
8	3		43.6667	25.6031	24.7341	0.0018	-0.0011	0.0001	-0.0011
8	4		45.3835	25.6961	25.0052	0.0008	0.0004	0.0000	0.0002
8	5		47.1893	25.6554	25.2774	0.0014	-0.0006	-0.0002	-0.0007
9	1		39.0643	29.8538	16.7170	0.0030	-0.0030	-0.0001	-0.0035
9	2		40.5011	30.3417	16.9904	0.0015	-0.0017	-0.0000	-0.0018
9	3		42.1535	30.7123	17.2747	0.0016	-0.0007	0.0000	-0.0009
9	4		43.9291	30.9652	17.5638	0.0018	-0.0013	0.0002	-0.0013
9	5		45.8174	31.0961	17.8564	0.0031	-0.0024	-0.0000	-0.0023
TOOTH 9			FLANK 1						
1	1		37.8475	0.6246	76.7222	0.0000	-0.0007	0.0001	-0.0007
1	2		38.7958	0.3877	76.8361	0.0001	-0.0009	-0.0001	-0.0008
1	3		39.8687	-0.0012	76.9773	0.0003	-0.0008	0.0000	-0.0006
1	4		40.9568	-0.5005	77.1169	0.0008	-0.0023	-0.0002	-0.0017
1	5		42.0743	-1.1074	77.2623	0.0005	-0.0034	0.0000	-0.0026
2	1		39.1630	2.9323	69.2216	-0.0000	-0.0003	0.0002	-0.0002
2	2		40.1865	2.7335	69.3548	0.0008	-0.0013	0.0001	-0.0010
2	3		41.3366	2.3799	69.5091	0.0010	-0.0028	-0.0001	-0.0023
2	4		42.5179	1.9139	69.6708	0.0013	-0.0035	0.0001	-0.0026
2	5		43.7239	1.3345	69.8314	0.0005	-0.0029	0.0002	-0.0022
3	1		40.2961	5.6542	61.7142	0.0005	0.0007	0.0001	0.0006
3	2		41.3856	5.5056	61.8683	0.0006	-0.0008	0.0001	-0.0007
3	3		42.6168	5.2074	62.0440	0.0009	-0.0020	0.0001	-0.0015
3	4		43.8960	4.7822	62.2238	0.0009	-0.0037	0.0002	-0.0030
3	5		45.2063	4.2500	62.4042	0.0006	-0.0039	0.0001	-0.0031
4	1		41.1635	8.7846	54.2136	-0.0000	0.0003	0.0001	0.0003
4	2		42.3422	8.7044	54.3884	0.0010	-0.0001	0.0001	0.0001
4	3		43.6589	8.4700	54.5811	0.0007	-0.0011	0.0000	-0.0009
4	4		45.0240	8.1149	54.7784	0.0004	-0.0028	-0.0001	-0.0024
4	5		46.4400	7.6354	54.9754	0.0015	-0.0039	0.0001	-0.0029
5	1		41.7375	12.3183	46.7132	0.0001	-0.0003	0.0001	-0.0002
5	2		42.9710	12.3157	46.9050	0.0008	0.0010	0.0000	0.0009
5	3		44.3695	12.1686	47.1180	0.0004	-0.0005	-0.0001	-0.0005
5	4		45.8338	11.8909	47.3332	0.0005	-0.0011	-0.0005	-0.0011
5	5		47.3491	11.4960	47.5481	0.0015	-0.0022	0.0002	-0.0015
6	1		41.8922	16.2267	39.2155	0.0006	-0.0014	0.0000	-0.0014
6	2		43.1926	16.3281	39.4244	0.0002	0.0014	0.0002	0.0013
6	3		44.6727	16.2771	39.6557	0.0001	0.0005	0.0001	0.0005
6	4		46.2238	16.1042	39.8891	0.0011	-0.0008	0.0003	-0.0005
6	5		47.8443	15.8030	40.1230	0.0013	-0.0013	-0.0005	-0.0013



TABLE 1. (Cont'd)

C	I	X	Y	Z	DX	DY	DZ	EN
7	1	41.5628	20.4879	31.7149	0.0003	-0.0004	0.0002	-0.0004
7	2	42.9199	20.6967	31.9465	0.0013	0.0003	-0.0000	0.0000
7	3	44.4672	20.7733	32.1954	0.0013	0.0007	0.0002	0.0006
7	4	46.1087	20.7175	32.4453	0.0005	0.0012	-0.0000	0.0010
7	5	47.8286	20.5393	32.7001	0.0016	-0.0017	0.0001	-0.0013
8	1	40.6611	25.0588	24.2153	-0.0005	0.0013	-0.0003	0.0010
8	2	42.0609	25.3935	24.4671	-0.0005	0.0017	0.0004	0.0017
8	3	43.6667	25.6033	24.7341	0.0014	-0.0008	-0.0002	-0.0009
8	4	45.3835	25.6955	25.0052	0.0012	-0.0002	0.0002	-0.0002
8	5	47.1893	25.6561	25.2774	0.0007	-0.0001	-0.0000	-0.0002
9	1	39.0643	29.8605	16.7170	-0.0005	0.0014	0.0000	0.0012
9	2	40.5011	30.3440	16.9904	0.0004	-0.0001	0.0002	-0.0001
9	3	42.1535	30.7138	17.2747	0.0005	0.0004	0.0001	0.0002
9	4	43.9291	30.9650	17.5638	0.0024	-0.0013	0.0001	-0.0014
9	5	45.8174	31.0969	17.8564	0.0025	-0.0017	-0.0001	-0.0017
TOOTH 13		FLANK 1						
1	1	37.8475	0.6255	76.7222	-0.0003	0.0001	0.0002	0.0001
1	2	38.7958	0.3862	76.8361	0.0005	-0.0025	-0.0000	-0.0022
1	3	39.8687	-0.0038	76.9773	0.0006	-0.0033	-0.0003	-0.0029
1	4	40.9568	-0.5026	77.1169	0.0012	-0.0047	0.0001	-0.0036
1	5	42.0743	-1.1093	77.2623	0.0009	-0.0056	0.0000	-0.0043
2	1	39.1630	2.9331	69.2216	-0.0001	0.0006	-0.0001	0.0006
2	2	40.1865	2.7345	69.3548	0.0009	-0.0003	0.0000	-0.0001
2	3	41.3306	2.3796	69.5091	0.0001	-0.0028	-0.0002	-0.0026
2	4	42.5179	1.9126	69.6708	0.0011	-0.0048	0.0002	-0.0037
2	5	43.7239	1.3331	69.8314	0.0011	-0.0046	0.0000	-0.0034
3	1	40.2961	5.6561	61.7142	-0.0007	0.0025	0.0001	0.0024
3	2	41.3856	5.5063	61.8683	0.0012	-0.0003	0.0001	-0.0001
3	3	42.6168	5.2082	62.0440	-0.0000	-0.0009	-0.0001	-0.0009
3	4	43.8960	4.7821	62.2238	0.0013	-0.0039	0.0001	-0.0031
3	5	45.2063	4.2491	62.4042	0.0020	-0.0052	-0.0001	-0.0039
4	1	41.1635	8.7870	54.2136	-0.0002	0.0026	0.0001	0.0025
4	2	42.3422	8.7050	54.3884	0.0011	0.0003	0.0005	0.0005
4	3	43.6589	8.4702	54.5811	0.0009	-0.0008	-0.0001	-0.0006
4	4	45.0240	8.1156	54.7784	0.0010	-0.0022	0.0001	-0.0017
4	5	46.4400	7.6352	54.9754	0.0021	-0.0042	0.0001	-0.0031
5	1	41.7375	12.3193	46.7132	0.0001	0.0008	-0.0001	0.0007
5	2	42.9710	12.3170	46.9050	-0.0002	0.0024	-0.0001	0.0021
5	3	44.3675	12.1668	47.1160	0.0004	-0.0004	-0.0000	0.0003
5	4	45.8338	11.8912	47.3332	0.0011	-0.0012	-0.0000	-0.0009
5	5	47.3491	11.4974	47.5401	0.0002	-0.0005	0.0001	-0.0003
6	1	41.2922	16.2298	39.2155	-0.0006	0.0011	0.0002	0.0012
6	2	42.1926	16.3282	39.4244	0.0001	0.0016	0.0000	0.0014

TABLE 1. (Cont'd)

C	L	X	Y	Z	DX	DY	DZ	EN
6	3	44.6727	16.2786	39.6557	0.0001	0.0021	0.0002	0.0019
6	4	46.2238	15.1052	39.8891	0.0002	0.0004	0.0002	0.0004
6	5	47.8443	15.8045	40.1230	0.0006	-0.0001	-0.0000	-0.0001
7	1	41.5628	20.4918	31.7149	-0.0020	0.0026	0.0002	0.0028
7	2	42.9199	20.6976	31.9465	0.0001	0.0010	0.0000	0.0008
7	3	44.4672	20.7743	32.1954	-0.0003	0.0017	-0.0000	0.0014
7	4	46.1987	20.7192	32.4453	-0.0010	0.0026	0.0003	0.0024
7	5	47.8286	20.5422	32.7001	0.0002	0.0014	-0.0001	0.0011
8	1	40.6611	25.0595	24.2153	-0.0009	0.0015	0.0001	0.0015
8	2	42.0609	25.3955	24.4671	-0.0020	0.0033	0.0002	0.0033
8	3	43.6667	25.6049	24.7341	0.0002	0.0005	-0.0000	0.0003
8	4	45.3835	25.6963	25.0052	0.0009	0.0006	0.0001	0.0005
8	5	47.1893	25.6592	25.2774	-0.0009	0.0028	0.0001	0.0023
9	1	39.0643	29.8621	16.7170	-0.0014	0.0023	0.0001	0.0023
9	2	40.5011	30.3465	16.9904	-0.0015	0.0019	-0.0002	0.0018
9	3	42.1535	30.7180	17.2747	-0.0025	0.0039	-0.0002	0.0035
9	4	43.9291	30.9685	17.5638	-0.0004	0.0014	0.0001	0.0012
9	5	45.8174	31.0994	17.8564	0.0007	0.0005	-0.0001	0.0002

TABLE 2. ZEISS MEASUREMENTS OF MASTER GEAR

```

=====
MEASURE RECORD    ZEISS RAM 2B
RGEAR 08114
=====
DRAWING NO      | PART NO | ORDER NO      | SUPPLIER/CUSTOMER | OPERATION
Z-08114-S      | T15     | NA            | SIKORSKY           | INSP FLANK

OPERATOR        | DATE
O'DONNELL      | 24Nov1982
=====
C | I | X | Y | Z | DX | DY | DZ | EN
=====
ALIGNMENT MODE 0
TOOTH 1         FLANK 1
1 1 184.3812 11.4635 50.9900 -0.0001 -0.0005 -0.0002 -0.0006
1 2 184.4749 11.2007 52.0935 -0.0005 -0.0010 0.0004 -0.0010
1 3 184.5656 10.9339 53.1939 -0.0003 -0.0009 -0.0000 -0.0009
1 4 184.6512 10.6607 54.2890 -0.0004 -0.0006 -0.0004 -0.0008
1 5 184.7290 10.3778 55.3824 -0.0008 -0.0008 0.0010 -0.0005

2 1 192.0446 9.4233 48.3015 -0.0007 -0.0005 0.0002 -0.0007
2 2 192.2119 9.1286 49.4642 -0.0006 -0.0006 -0.0000 -0.0007
2 3 192.3731 8.8283 50.6235 0.0001 -0.0011 0.0002 -0.0010
2 4 192.5271 8.5171 51.7822 -0.0005 -0.0009 0.0002 -0.0009
2 5 192.6752 8.1953 52.9417 -0.0004 -0.0007 -0.0002 -0.0008

3 1 199.5096 6.9780 45.6071 -0.0004 -0.0003 0.0006 -0.0003
3 2 199.7430 6.6446 46.8330 -0.0004 -0.0007 -0.0000 -0.0008
3 3 199.9674 6.3014 48.0532 -0.0002 -0.0008 0.0002 -0.0008
3 4 200.1882 5.9442 49.2788 -0.0003 -0.0005 0.0002 -0.0008
3 5 200.4059 5.5760 50.5046 -0.0004 -0.0007 -0.0000 -0.0008

4 1 206.7736 4.1363 42.9117 0.0005 -0.0008 -0.0002 -0.0005
4 2 207.0707 3.7532 44.1974 -0.0002 -0.0009 0.0004 -0.0008
4 3 207.3607 3.3553 45.4820 -0.0003 -0.0010 0.0002 -0.0010
4 4 207.6460 2.9462 46.7755 -0.0001 -0.0009 -0.0002 -0.0009
4 5 207.9234 2.5278 48.0627 -0.0006 -0.0007 0.0002 -0.0008

5 1 213.8444 0.8963 40.2085 -0.0004 -0.0004 -0.0002 -0.0005
5 2 214.1991 0.4544 41.5636 -0.0001 -0.0010 -0.0000 -0.0007
5 3 214.5491 -0.0012 42.9172 -0.0006 -0.0007 -0.0000 -0.0009
5 4 214.8949 -0.4686 44.2708 -0.0003 -0.0009 -0.0000 -0.0009
5 5 215.2316 -0.9479 45.6245 -0.0002 -0.0007 -0.0000 -0.0007

6 1 220.7165 -2.7402 37.5894 0.0001 -0.0007 -0.0002 -0.0005
6 2 221.1303 -3.2483 38.9287 -0.0003 -0.0009 0.0002 -0.0009
6 3 221.5364 -3.7691 40.3465 -0.0004 -0.0008 0.0002 -0.0009
6 4 221.9370 -4.3034 41.7660 -0.0004 -0.0011 -0.0002 -0.0012
6 5 222.3309 -4.8509 43.1843 -0.0004 -0.0007 0.0002 -0.0007

7 1 227.3934 -6.7766 34.8099 -0.0002 -0.0008 -0.0002 -0.0008
7 2 227.8601 -7.3568 36.2948 -0.0006 -0.0008 0.0002 -0.0010
7 3 228.3186 -7.9515 37.7777 -0.0005 -0.0009 -0.0006 -0.0011
=====

```

TAB E 2. (Cont'd)

C	L	X	Y	Z	DX	DY	DZ	EN
7	4	228.7769	-8.5609	39.2638	-0.0005	-0.0009	-0.0002	-0.0010
7	5	229.2151	-9.1825	41.7471	-0.0000	-0.0009	-0.0000	-0.0007
8	1	233.8700	-11.2176	32.1118	-0.0007	-0.0008	0.0004	-0.0010
8	2	234.3847	-11.8789	33.6581	-0.0005	-0.0009	-0.0002	-0.0010
8	3	234.2925	-12.5569	35.2059	0.0006	-0.0013	0.0016	-0.0005
8	4	235.3917	-13.2488	36.7574	-0.0003	-0.0010	0.0002	-0.0009
8	5	235.8865	-13.9562	38.3093	-0.0007	-0.0008	-0.0000	-0.0011
9	1	240.1425	-16.0746	29.4060	-0.0002	-0.0009	0.0002	-0.0008
9	2	240.7007	-16.8278	31.0240	-0.0008	-0.0010	0.0002	-0.0013
9	3	241.2507	-17.5953	32.6416	-0.0005	-0.0014	-0.0002	-0.0014
9	4	241.7960	-18.3810	34.2556	-0.0004	-0.0008	0.0000	-0.0009
9	5	242.3357	-19.1781	35.8751	-0.0004	-0.0011	-0.0002	-0.0010
TOOTH	10	FLANK	1					
1	1	184.3812	11.4649	50.9900	0.0003	0.0007	-0.0001	0.0007
1	2	184.4749	11.2023	52.0935	0.0001	0.0004	-0.0001	0.0004
1	3	184.5656	10.9342	53.1939	-0.0004	-0.0008	0.0010	-0.0007
1	4	184.6512	10.6600	54.2890	-0.0007	-0.0013	-0.0002	-0.0015
1	5	184.7290	10.3776	55.3324	-0.0003	-0.0010	0.0010	-0.0008
2	1	192.0446	9.4242	48.3015	0.0005	-0.0000	-0.0002	0.0001
2	2	192.2119	9.1283	49.4642	-0.0004	-0.0009	-0.0004	-0.0010
2	3	192.3731	8.8271	50.6235	-0.0010	-0.0019	-0.0001	-0.0021
2	4	192.5271	8.5166	51.7822	-0.0004	-0.0014	0.0001	-0.0014
2	5	192.6732	8.1952	52.9417	-0.0006	-0.0008	0.0001	-0.0009
3	1	199.5095	6.9770	45.6071	-0.0006	-0.0011	-0.0001	-0.0012
3	2	199.7438	6.6430	46.8330	-0.0011	-0.0021	0.0002	-0.0023
3	3	199.9674	6.3009	48.0532	-0.0005	-0.0012	-0.0002	-0.0013
3	4	200.1882	5.9439	49.2780	-0.0004	-0.0007	-0.0002	-0.0008
3	5	200.4059	5.5756	50.5046	-0.0004	-0.0011	0.0000	-0.0011
4	1	206.7736	4.1342	42.9117	-0.0003	-0.0025	0.0001	-0.0024
4	2	207.0797	3.7524	44.1974	-0.0010	-0.0012	0.0001	-0.0015
4	3	207.3607	3.3559	45.4820	-0.0004	-0.0012	-0.0001	-0.0013
4	4	207.6450	2.9459	46.7755	-0.0004	-0.0011	0.0002	-0.0011
4	5	207.9234	2.5277	48.0627	-0.0006	-0.0008	-0.0002	-0.0010
5	1	213.8444	0.8944	40.2085	-0.0012	-0.0019	0.0000	-0.0022
5	2	214.1991	0.4541	41.5636	-0.0008	-0.0012	-0.0001	-0.0011
5	3	214.5491	-0.0017	42.9172	-0.0006	-0.0013	0.0001	-0.0014
5	4	214.8947	-0.4594	44.2709	-0.0005	-0.0015	-0.0001	-0.0015
5	5	215.2316	-0.8482	45.6245	-0.0004	-0.0008	-0.0002	-0.0009
6	1	220.7165	-2.7412	37.5094	-0.0007	-0.0017	0.0002	-0.0013
6	2	221.1393	-3.2485	38.9287	-0.0008	-0.0006	0.0003	-0.0011

TABLE 2. (Cont'd)

C	L	X	Y	Z	DX	DY	DZ	EN
6	3	221.5364	-3.7697	40.3465	-0.0008	-0.0012	-0.0001	-0.0014
6	4	221.9370	-4.3051	41.7660	-0.0003	-0.0009	-0.0001	-0.0009
6	5	222.3309	-4.8513	43.1843	-0.0004	-0.0010	-0.0000	-0.0010
7	1	227.3934	-6.7776	34.8099	-0.0012	-0.0012	0.0002	-0.0016
7	2	227.8601	-7.3577	36.2928	-0.0008	-0.0015	-0.0001	-0.0017
7	3	228.3186	-7.9516	37.7777	-0.0004	-0.0011	0.0001	-0.0011
7	4	228.7709	-8.5615	39.2638	-0.0008	-0.0013	0.0002	-0.0015
7	5	229.2151	-9.1851	40.7471	-0.0011	-0.0026	0.0000	-0.0027
8	1	233.6700	-11.2190	32.1116	-0.0011	-0.0019	0.0000	-0.0021
8	2	234.3847	-11.8796	33.6581	-0.0011	-0.0011	-0.0001	-0.0016
8	3	234.8925	-12.5572	35.2059	0.0001	-0.0014	0.0020	-0.0007
8	4	235.3917	-13.2510	36.7574	-0.0010	-0.0025	-0.0004	-0.0026
8	5	235.8865	-13.9581	38.3098	-0.0014	-0.0022	0.0001	-0.0026
9	1	240.1425	-15.0753	29.4080	-0.0006	-0.0012	0.0001	-0.0013
9	2	240.7007	-16.8280	31.0240	-0.0007	-0.0013	0.0002	-0.0014
9	3	241.2507	-17.5986	32.6416	-0.0017	-0.0036	0.0000	-0.0038
9	4	241.7960	-18.3851	34.2556	-0.0008	-0.0028	0.0013	-0.0024
9	5	242.3359	-19.1790	35.8751	-0.0009	-0.0016	0.0005	-0.0017
TOOTH 20	FLANK	1						
1	1	184.3812	11.4663	50.9900	0.0014	0.0017	-0.0003	0.0020
1	2	184.4749	11.2015	52.0935	-0.0000	-0.0004	0.0003	-0.0003
1	3	184.5656	10.9328	53.1939	-0.0011	-0.0018	-0.0000	-0.0020
1	4	184.6512	10.6579	54.2890	-0.0019	-0.0031	0.0002	-0.0034
1	5	184.7290	10.3761	55.3824	-0.0010	-0.0019	-0.0002	-0.0021
2	1	192.0446	9.4234	48.3015	-0.0007	-0.0005	-0.0000	-0.0006
2	2	192.2119	9.1272	49.4642	-0.0008	-0.0019	0.0000	-0.0020
2	3	192.3731	8.8249	50.6235	-0.0017	-0.0038	-0.0001	-0.0041
2	4	192.5271	8.5152	51.7822	-0.0014	-0.0023	-0.0003	-0.0027
2	5	192.6752	8.1951	52.9417	-0.0002	-0.0010	0.0004	-0.0010
3	1	199.5096	6.9759	45.6071	-0.0011	-0.0021	0.0003	-0.0023
3	2	199.7430	6.6403	46.8330	-0.0019	-0.0043	-0.0003	-0.0047
3	3	199.9674	6.2988	48.0532	-0.0018	-0.0027	-0.0000	-0.0032
3	4	200.1882	5.9440	49.2788	-0.0001	-0.0008	0.0000	-0.0008
3	5	200.4059	5.5766	50.5046	-0.0002	-0.0002	0.0001	-0.0003
4	1	206.7736	4.1316	42.9117	-0.0015	-0.0044	-0.0004	-0.0046
4	2	207.0707	3.7499	44.1974	-0.0018	-0.0033	-0.0001	-0.0037
4	3	207.3607	3.3548	45.4820	-0.0005	-0.0014	0.0001	-0.0014
4	4	207.6460	2.9465	46.7755	-0.0003	-0.0005	-0.0000	-0.0006
4	5	207.9234	2.5285	48.0627	-0.0002	-0.0001	-0.0001	-0.0002
5	1	213.8444	0.8913	40.2085	-0.0024	-0.0043	0.0001	-0.0048

TABLE 2. (Cont'd)

C	L	X	Y	Z	DX	DY	DZ	EN
5	2	214.1991	0.4532	41.5636	-0.0008	-0.0016	-0.0004	-0.0019
5	3	214.5491	-0.0012	42.9172	-0.0004	-0.0009	-0.0001	-0.0010
5	4	214.8949	-0.4683	44.2708	-0.0004	-0.0006	0.0004	-0.0006
5	5	215.2316	-0.9484	45.6245	-0.0007	-0.0008	-0.0004	-0.0011
6	1	220.7165	-2.7430	37.5094	-0.0012	-0.0027	0.0001	-0.0029
6	2	221.1303	-3.2485	38.9287	-0.0004	-0.0010	-0.0002	-0.0011
6	3	221.5364	-3.7587	40.3465	-0.0001	-0.0006	0.0001	-0.0006
6	4	221.9370	-4.3033	41.7660	-0.0003	-0.0011	-0.0000	-0.0011
6	5	222.3309	-4.8534	43.1843	-0.0013	-0.0023	-0.0005	-0.0027
7	1	227.3934	-6.7773	34.8099	-0.0004	-0.0014	0.0001	-0.0014
7	2	227.8601	-7.3566	36.2948	-0.0008	-0.0005	0.0002	-0.0008
7	3	228.3186	-7.9517	37.7777	-0.0005	-0.0012	-0.0001	-0.0013
7	4	228.7709	-8.5631	39.2638	-0.0013	-0.0025	-0.0004	-0.0028
7	5	229.2151	-9.1866	40.7471	-0.0017	-0.0037	0.0005	-0.0039
8	1	233.8700	-11.2181	32.1118	-0.0010	-0.0010	-0.0003	-0.0014
8	2	234.3847	-11.8788	33.6581	-0.0001	-0.0011	0.0000	-0.0009
8	3	234.8925	-12.5592	35.2059	-0.0012	-0.0020	-0.0001	-0.0023
8	4	235.3917	-13.2529	36.7574	-0.0020	-0.0037	0.0000	-0.0041
8	5	235.8865	-13.9573	38.3098	-0.0012	-0.0016	0.0001	-0.0020
9	1	240.1425	-16.0743	29.4080	0.0001	-0.0009	0.0003	-0.0006
9	2	240.7007	-16.8297	31.0240	-0.0013	-0.0024	-0.0003	-0.0026
9	3	241.2507	-17.6005	32.6416	-0.0026	-0.0047	-0.0009	-0.0052
9	4	241.7960	-18.3834	34.2556	-0.0010	-0.0028	0.0001	-0.0027
9	5	242.3359	-19.1750	35.8751	0.0008	0.0009	0.0000	0.0012
TOOTH 30			FLANK 1					
1	1	184.3812	11.4651	50.9900	0.0009	0.0006	0.0000	0.0008
1	2	184.4749	11.2009	52.0935	-0.0003	-0.0008	0.0000	-0.0008
1	3	184.5656	10.9318	53.1939	-0.0012	-0.0028	-0.0001	-0.0030
1	4	184.6512	10.6558	54.2890	-0.0023	-0.0049	-0.0003	-0.0053
1	5	184.7290	10.3742	55.3824	-0.0020	-0.0038	0.0006	-0.0040
2	1	192.0446	9.4230	48.3015	-0.0003	-0.0011	0.0002	-0.0010
2	2	192.2119	9.1257	49.4642	-0.0017	-0.0030	-0.0002	-0.0034
2	3	192.3731	8.8231	50.6235	-0.0026	-0.0053	-0.0001	-0.0056
2	4	192.5271	8.5135	51.7822	-0.0017	-0.0039	-0.0001	-0.0042
2	5	192.6752	8.1946	52.9417	-0.0007	-0.0013	-0.0002	-0.0015
3	1	199.5096	6.9746	45.6071	-0.0014	-0.0032	0.0002	-0.0034
3	2	199.7430	6.6385	46.8330	-0.0028	-0.0059	0.0005	-0.0063
3	3	199.9674	6.2971	48.0532	-0.0022	-0.0042	-0.0003	-0.0047
3	4	200.1882	5.9430	49.2788	-0.0009	-0.0015	-0.0000	-0.0017
3	5	200.4059	5.5768	50.5046	-0.0000	-0.0001	0.0002	-0.0001

TABLE 2. (Cont'd)

C	I	L	X	Y	Z	DX	DY	DZ	EN
4	1		206.7736	4.1294	42.9117	-0.0027	-0.0061	-0.0002	-0.0067
4	2		207.0707	3.7471	44.1974	-0.0028	-0.0057	0.0005	-0.0062
4	3		207.3607	3.3534	45.4820	-0.0010	-0.0025	-0.0001	-9.0027
4	4		207.6460	2.9465	46.7755	-0.0003	-0.0005	-0.0002	-0.0006
4	5		207.9234	2.5290	48.0627	0.0004	0.0001	-0.0001	0.0002
5	1		213.8444	0.8889	40.2085	-0.0033	-0.0061	-0.0000	-0.0069
5	2		214.1991	0.4515	41.5636	-0.0014	-0.0030	-0.0001	-0.0033
5	3		214.5491	-0.0012	42.9172	-0.0006	-0.0008	0.0002	-0.0009
5	4		214.8949	-0.4677	44.2708	-0.0001	-0.0001	0.0003	-0.0001
5	5		215.2316	-0.9477	45.6245	-0.0003	-0.0005	0.0001	-0.0005
6	1		220.7165	-2.7449	37.5094	-0.0018	-0.0042	-0.0002	-0.0045
6	2		221.1303	-3.2481	38.9287	-0.0004	-0.0007	0.0003	-0.0007
6	3		221.5364	-3.7682	40.3465	-0.0004	-0.0000	-0.0000	-0.0002
6	4		221.9370	-4.3029	41.7660	-0.0003	-0.0007	-0.0001	-0.0008
6	5		222.3309	-4.8532	43.1843	-0.0008	-0.0020	-0.0004	-0.0026
7	1		227.3934	-6.7780	34.8099	-0.0008	-0.0018	-0.0000	-0.0019
7	2		227.8601	-7.3563	36.2948	-0.0003	-0.0005	0.0001	-0.0006
7	3		228.3186	-7.9512	37.7777	-0.0002	-0.0008	-0.0004	-0.0008
7	4		228.7709	-8.5631	39.2638	-0.0017	-0.0023	0.0003	-0.0028
7	5		229.2151	-9.1866	40.7471	-0.0020	-0.0035	0.0001	-0.0040
8	1		233.8700	-11.2173	32.1118	-0.0004	-0.0007	-0.0000	-0.0008
8	2		234.3847	-11.8779	33.6581	-0.0002	-0.0001	-0.0001	-0.0003
8	3		234.8925	-12.5585	35.2059	-0.0003	-0.0023	0.0018	-0.0018
8	4		235.3917	-13.2536	36.7574	-0.0019	-0.0045	-0.0000	-0.0046
8	5		235.8865	-13.9586	38.3098	-0.0014	-0.0028	0.0001	-0.0029
9	1		240.1425	-16.0735	29.4080	-0.0003	0.0003	-0.0002	0.0000
9	2		240.7007	-16.8290	31.0240	-0.0011	-0.0020	0.0005	-0.0021
9	3		241.2507	-17.6007	32.6416	-0.0024	-0.0052	-0.0001	-0.0054
9	4		241.7960	-18.3843	34.2556	-0.0015	-0.0032	0.0000	-0.0033
9	5		242.3359	-19.1723	35.8751	-0.0003	-0.0004	-0.0004	-0.0004

## Discussion of Results

The improved measurement process for spiral bevel gears was successfully demonstrated using the Zeiss UMM 500 Coordinate Measuring Machine fitted with the Rotary Table. The gear set up and measurement process was accomplished easily and quickly with excellent repeatability. The total savings in inspection and grinding time is estimated to be 7 3/4 hours per gear.

As expected, the tooth profiles of the teeth on the master pinion and gear showed little deviation from the reference master tooth. The maximum deviation ranged from +.00009 to -.00015 for the pinion with corresponding values +.00005 and -.00032 for the gear.

## Correlation with Taped Patterns

A comparison of the Zeiss readings taken on the selected master gear set and the contact pattern observed in the Gleason test machine showed good correlation as evidenced by the fact that where a minus condition (negative derivation from the nominal values) was indicated by a Zeiss reading, a corresponding movement was noted in the contact pattern. Figure 21 shows a plot of derived test machine values compared to the UMM500 values. The test machine values plotted are the observed distances from the end of the test machine pattern to the toe end of the tooth. The UMM500 values are the measured surface deviation at the same point.

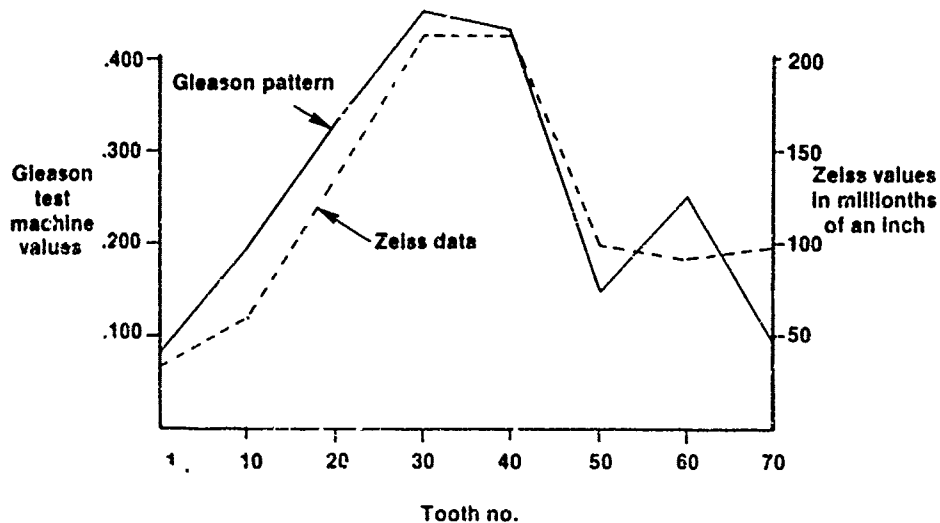

Figure 21. Comparison of Measurement Systems



### Comparison of Nominal Values

To judge the effectiveness of the Gleason computer program in determining nominal coordinate values based upon the final grinding machine settings, the coded data supplied by Gleason, for the selected master gear set, was loaded into the HP computer as the theoretical nominal values. The master gear set was then measured, as described above, and compared with these nominal values. The results are shown in the contour plots of Figures 22 and 23, and as tabular values in Tables 3 and 4. The tabular values are in mm.

At first glance, there appears to be an obvious and significant difference between the profile coordinates of the manufactured master gear set and the theoretical contour coordinates both produced by the same grinding machine settings. The maximum measured normal deviations between the two were  $-.00228/-0.00223$  inches for the pinion and  $+00057/-0.00188$  inches for the gear.

After consultation with Gleason, who reiterated their confidence in the computer program based upon corroborative evidence from their own research efforts, it was concluded that the actual machine settings used to produce the gears must have been different than the calculated theoretical values, possibly because of errors in machine gaging or machine set up. This is the reason that developed machine settings may be different for different machines, or for machines of different vintage, and that the final proof of compliance is comparison with an established master gear.

The conclusion drawn from this comparison is that the best way to obtain nominal values is digitization of an existing master gear which is traceable to the gear used in the qualification test program run on the actual gearbox.

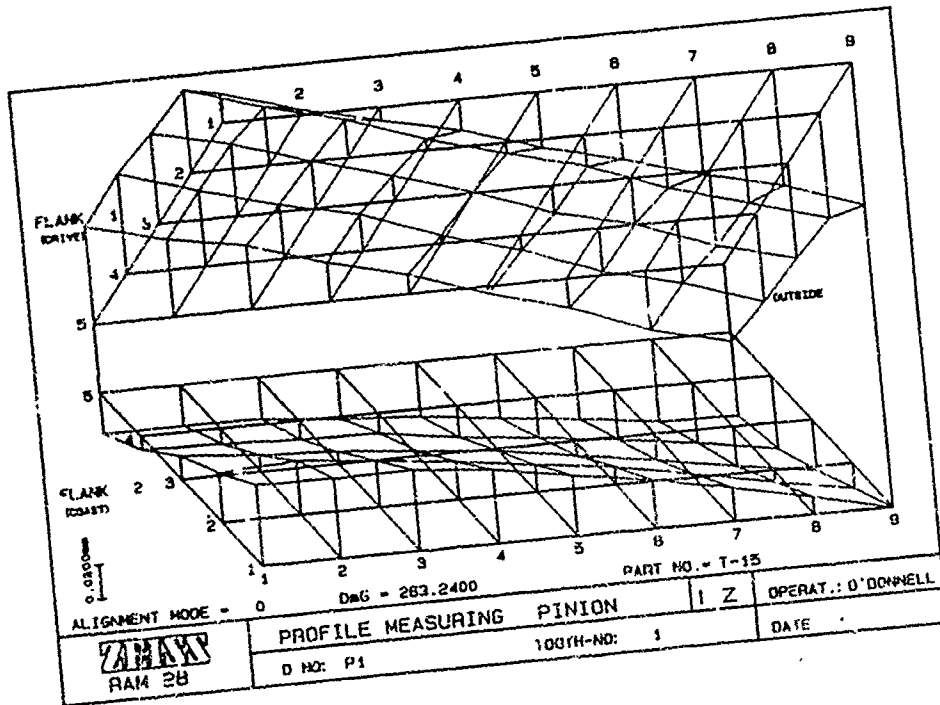

Figure 22. Comparison of Nominal Values - Pinion

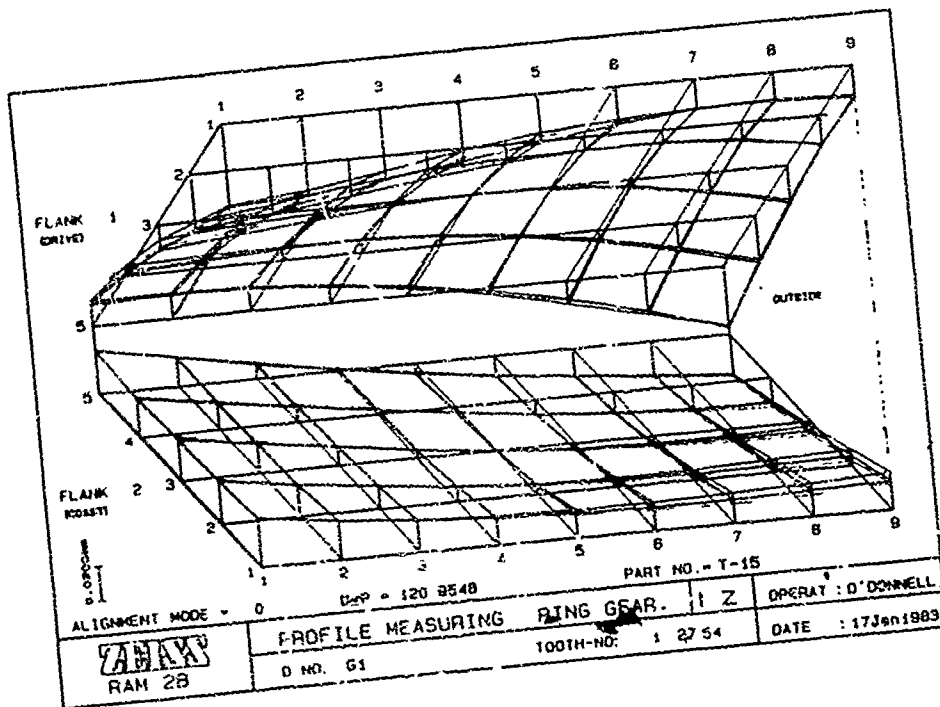

Figure 23. Comparison of Nominal Values - Gear

TABLE 3. COMPARISON OF NOMINAL VALUES-PINION

```

=====
MEASURE RECORD    ZEISS RAM 2B

PINION 08104-45
=====

DRAWING NO      | PART NO | ORDER NO      | SUPPLIER/CUSTOMER | OPERATION
P1              | T-15   | NA            | SIKORSKY           | INSP FLANK

OPERATOR        | DATE
O'DONNELL      | 19Jan1983
=====
C | L | X | Y | Z | DX | DY | DZ | EN
=====
ALIGNMENT MODE 0 MOUNTING DJST. DmG = 269.2400
TOOTH 1 FLANK 1
1 1 38.5027 0.6225 -197.8195 -0.0002 0.0175 -0.0003 0.0164
1 2 39.3178 0.4587 -197.6658 -0.0002 0.0526 0.0004 0.0479
1 3 40.4567 0.0585 -197.4371 0.0001 0.0585 0.0000 0.0521
1 4 41.8490 -0.5930 -197.1430 -0.0001 0.0679 0.0000 0.0579
1 5 43.4264 -1.5361 -196.7924 -0.0000 0.0700 0.0002 0.0567

2 1 39.7209 2.9056 -204.6607 -0.0002 0.0027 -0.0003 0.0024
2 2 40.5999 2.7663 -204.4886 -0.0020 0.0367 0.0000 0.0334
2 3 41.8158 2.4043 -204.2417 -0.0024 0.0473 -0.0001 0.0416
2 4 43.2988 1.7885 -203.9302 -0.0028 0.0520 -0.0001 0.0437
2 5 44.9801 0.8929 -203.5630 -0.0029 0.0572 0.0002 0.0459

3 1 40.7552 5.4945 -211.3789 0.0010 -0.0092 -0.0001 -0.0085
3 2 41.6974 5.3893 -211.1907 -0.0029 0.0235 0.0004 0.0213
3 3 42.9902 5.0719 -210.9282 -0.0037 0.0309 -0.0002 0.0268
3 4 44.5645 4.5122 -210.6019 -0.0048 0.0372 -0.0002 0.0308
3 5 46.3515 3.6817 -210.2209 -0.0056 0.0466 -0.0000 0.0368

4 1 41.5641 8.3641 -217.9704 0.0037 -0.0207 -0.0000 -0.0190
4 2 42.5677 8.2993 -217.7683 -0.0013 0.0063 -0.0000 0.0056
4 3 43.9357 8.0435 -217.4928 -0.0030 0.0159 -0.0000 0.0137
4 4 45.6000 7.5590 -217.1542 -0.0046 0.0253 0.0001 0.0210
4 5 47.4925 6.8011 -216.7619 -0.0053 0.0285 -0.0001 0.0223

5 1 42.1073 11.4823 -224.4317 0.0090 -0.0363 -0.0003 -0.0334
5 2 43.1695 11.4761 -224.2180 0.0020 -0.0081 0.0001 -0.0072
5 3 44.6092 11.2937 -223.9315 0.0001 0.0001 0.0001 0.0001
5 4 46.3601 10.8907 -223.5931 -0.0012 0.0052 -0.0000 0.0043
5 5 48.3552 10.2352 -223.1622 -0.0036 0.0139 0.0003 0.0110

6 1 42.3471 14.8250 -230.7594 0.0169 -0.0477 -0.0002 -0.0440
6 2 43.4639 14.8853 -230.5359 0.0066 -0.0208 0.0001 -0.0186
6 3 44.9700 14.7831 -230.2408 0.0063 -0.0189 -0.0001 -0.0164
6 4 46.8019 14.4970 -229.8848 0.0033 -0.0106 -0.0001 -0.0088
6 5 48.8941 13.9425 -229.4777 0.0018 -0.0059 -0.0001 -0.0047

7 1 42.2488 18.3481 -236.9502 0.0246 -0.0621 0.0002 -0.0572
7 2 43.4148 18.4831 -236.7186 0.0165 -0.0393 -0.0000 -0.0355
7 3 44.9804 18.4645 -236.4168 0.0127 -0.0315 0.0000 -0.0274
7 4 46.8553 18.3008 -236.0556 0.0125 -0.0319 0.0001 -0.0258
7 5 49.0654 17.8936 -235.6444 0.0096 -0.0214 0.0000 -0.0169

8 1 41.7819 22.0162 -243.0007 0.0365 -0.0719 0.0001 -0.0676
=====

```

TABLE 3. (Cont'd)

C	I	L	X	Y	Z	DX	DY	DZ	EN
8	2		42.9907	22.2370	-242.7626	0.0273	-0.0527	0.0001	-0.0483
8	3		44.6069	22.3474	-242.4561	0.0254	-0.0500	0.0002	-0.0441
8	4		46.5748	22.3008	-242.0917	0.0214	-0.0429	0.0000	-0.0363
8	5		48.8337	22.0337	-241.6791	0.0218	-0.0429	0.0001	-0.0343
9	1		40.9205	25.7734	-248.9080	0.0517	-0.0867	-0.0001	-0.0832
9	2		42.1644	26.0962	-248.6648	0.0398	-0.0656	0.0001	-0.0614
9	3		43.8212	26.3313	-248.3552	0.0369	-0.0616	0.0000	-0.0554
9	4		45.8396	26.4249	-247.9897	0.0361	-0.0599	0.0001	-0.0516
9	5		48.1628	26.3274	-247.5777	0.0330	-0.0551	-0.0002	-0.0452

TABLE 4. COMPARISON OF NOMINAL VALUES-GEAR

MEASURE RECORD ZEISS RAM 2B

RGEAR 08114

DRAWING NO | PART NO | ORDER NO | SUPPLIER/CUSTOMER | OPERATION  
 SIKORSKY | T15 | NA | SIKORSKY | INSP FLANK

OPERATOR | DATE  
 O'DONNELL | 30Nov1982

C	I	L	X	Y	Z	DX	DY	DZ	EN
ALIGNMENT MODE 0 FLANK 1 MOUNTING DIST. DmP = 120.9548									
1	1		188.4783	5.7157	-70.9360	-0.0221	-0.0443	0.0061	-0.0481
1	2		188.9199	5.3330	-69.8849	-0.0131	-0.0269	-0.0000	-0.0292
1	3		189.3409	4.9418	-68.8010	-0.0039	-0.0088	-0.0001	-0.0094
1	4		189.7401	4.5366	-67.6863	0.0021	0.0047	0.0003	0.0051
1	5		190.1163	4.1179	-66.5430	0.0064	0.0132	-0.0001	0.0142
2	1		194.9522	3.6746	-73.3879	-0.0197	-0.0398	0.0002	-0.0435
2	2		195.4139	3.2630	-72.2960	-0.0103	-0.0209	0.0003	-0.0227
2	3		195.8524	2.8408	-71.1713	-0.0023	-0.0049	-0.0003	-0.0053
2	4		196.2668	2.4055	-70.0158	0.0029	0.0055	-0.0000	0.0060
2	5		196.6559	1.9611	-68.8314	0.0064	0.0127	0.0005	0.0140
3	1		201.3221	1.3060	-75.8079	-0.0159	-0.0340	0.0003	-0.0369
3	2		201.8012	0.8618	-74.6745	-0.0072	-0.0147	0.0006	-0.0160
3	3		202.2548	0.4042	-73.5083	-0.0008	-0.0028	0.0000	-0.0028
3	4		202.6817	-0.0610	-72.3114	0.0027	0.0065	-0.0002	0.0068
3	5		203.0811	-0.5325	-71.0856	0.0060	0.0124	0.0000	0.0135
4	1		207.5723	-1.3855	-78.1931	-0.0128	-0.0268	0.0003	-0.0292
4	2		208.0661	-1.8684	-77.0175	-0.0050	-0.0110	0.0000	-0.0119
4	3		208.5319	-2.3610	-75.8094	-0.0008	-0.0010	-0.0004	-0.0013
4	4		208.9687	-2.8572	-74.5706	0.0030	0.0062	0.0008	0.0069
4	5		209.3757	-3.3593	-73.3030	0.0048	0.0090	-0.0001	0.0100

TABLE 4. (Cont'd)

C	L	X	Y	Z	DX	DY	DZ	EN
5	1	213.6873	-4.3965	-80.5409	-0.0103	-0.0211	0.0001	-0.0231
5	2	214.1928	-4.9200	-79.3225	-0.0044	-0.0085	0.0003	-0.0093
5	3	214.6678	-5.4477	-78.0719	0.0001	-0.0005	-0.0001	-0.0004
5	4	215.1117	-5.9771	-76.7908	0.0024	0.0048	-0.0002	0.0052
5	5	215.5236	-6.5098	-75.4812	0.0027	0.0048	-0.0001	0.0054
6	1	219.6516	-7.7206	-82.8488	-0.0090	-0.0172	-0.0001	-0.0191
6	2	220.1657	-8.2843	-81.5872	-0.0030	-0.0074	-0.0002	-0.0077
6	3	220.6471	-8.8490	-80.2936	-0.0003	-0.0009	-0.0002	-0.0010
6	4	221.0952	-9.4135	-78.9699	0.0008	0.0011	0.0002	0.0013
6	5	221.5092	-9.9771	-77.6179	-0.0004	-0.0015	0.0008	-0.0013
7	1	225.4504	-11.3491	-85.1147	-0.0076	-0.0155	0.0004	-0.0167
7	2	225.9699	-11.9546	-83.8694	-0.0031	-0.0075	-0.0004	-0.0078
7	3	226.4546	-12.5574	-82.4724	-0.0018	-0.0032	-0.0001	-0.0037
7	4	226.9039	-13.1580	-81.1056	-0.0024	-0.0046	-0.0002	-0.0051
7	5	227.3174	-13.7530	-79.7108	-0.0034	-0.0098	-0.0001	-0.0103
8	1	231.0690	-15.2742	-87.3365	-0.0076	-0.0151	0.0002	-0.0163
8	2	231.5906	-15.9226	-85.9869	-0.0048	-0.0096	-0.0002	-0.0104
8	3	232.0756	-16.5666	-84.6061	-0.0047	-0.0097	-0.0002	-0.0104
8	4	232.5233	-17.2019	-83.1958	-0.0060	-0.0137	0.0009	-0.0141
8	5	232.9334	-17.8287	-81.7580	-0.0101	-0.0211	0.0008	-0.0223
9	1	236.4932	-19.4857	-89.5122	-0.0072	-0.0174	0.0002	-0.0176
9	2	237.0137	-20.1803	-88.1179	-0.0072	-0.0157	0.0003	-0.0163
9	3	237.4957	-20.8646	-86.6927	-0.0087	-0.0189	0.0007	-0.0195
9	4	237.9389	-21.5355	-85.2386	-0.0121	-0.0244	-0.0001	-0.0260
9	5	238.3430	-22.1919	-83.7574	-0.0162	-0.0338	-0.0001	-0.0355

## DEVELOPMENT OF AN IN-PROCESS INSPECTION TECHNIQUE

One of the prime requirements identified at the outset for an improved spiral bevel gear inspection method is that; if the profile deviations of a production gear, as measured on the coordinate measuring machine, are beyond acceptable limits; these deviations must be interpretable in terms of specific delta changes to the grinding machine setting used to produce that gear. The procedure is essentially the inverse of the mathematical simulation process described earlier and is accomplished by a second part of the Gleason Works G-Age software package described below.

### G-Age Corrective Process

After a spiral bevel gear set has been "developed" for operation in a particular gearbox, the final grinding machine settings are used to calculate the theoretical surface coordinate and normals. This information is stored in the measuring machine computer. Along with this theoretical surface data, a corrective matrix is also generated and stored. The corrective matrix can be considered as a surface sensitivity matrix. For example, changes that affect the pressure angle and spiral angle of the tooth surface are defined. The sensitivity of the surface to these changes is calculated and stored in the corrective matrix. Changes are so defined for all Gleason cutting and grinding methods.

When the tooth surfaces of the individual gears are measured and compared to the nominal value matrix (either calculated theoretical surface points or measured surface points from a master gear), a matrix of error data is computed and stored. The error data is then multiplied by the corrective matrix and corrective settings for the grinding machine are calculated and printed out.

### Sensitivity Study

To evaluate this in-process inspection technique, which will convert readings from the Zeiss UMM500 measuring machine into precise settings for the spiral bevel gear grinding machine, a sensitivity study was made in which gear test specimens were ground and reground with machine settings that purposely deviated from the developed summary settings according to the matrices of Figures 24 and 25. This study involved 10 first order changes and 8 second and third order changes for the pinion and 10 first order changes for the gear. Each setting change consisted of 5 variations including one baseline, for a total of 91 grinds for the pinion and 51 grinds for the gear.

### Fabrication of Test Gear Specimens

The 10 pinion test specimens and 5 gear test specimens, which were machined in Phase I, were ground according to the grinding matrix of Figure 24 and 25. For each setting, two deviations above and two deviations below the established values were used. When all of the grinds at one machine setting were completed, a verification grind was made to reestablish the baseline settings before proceeding on to the next machine setting.

GLEASON GRINDER FIRST ORDER CHANGES

SETTING / GRIND #	1	2	3	4	6	7	8	9	10	11	12	13	14	15	16	17	18	19	20	21	22	23	24	25	26	27	28	29	30	31	32	33	34	35	36	37	38	39	40	41	42	43	44	45	46	47	48	49	50	51					
BASLINE	Z																																																						
MACHINE CENTER TO BACK	X	X	Y	Y	Z																																																		
ECCENTRIC ANGLE						X	X	Y	Y	Z																																													
BLANK OFFSET											X	X	Y	Y	Z																																								
SLIDING BASE																X	X	Y	Y	Z																																			
ROOT ANGLE																					X	X	Y	Y	Z																														
CRADLE ANGLE																										X	X	Y	Y	Z																									
CAM GUIDE ANGLE																															X	X	Y	Y	Z																				
CAM POSITION																																				X	X	Y	Y	Z															
SIDE DRESSER OFFSET																																									X	X	Y	Y	Z										
PRESSURE ANGLE																																														X	X	Y	Y	Z					

LEGEND

- X = Machine Setting Change
- Y = 2 times X Machine Setting Change
- Z = Verification Grind

Figure 24. First Order Grinding Matrix

GLEASON GRINDER SECOND AND THIRD ORDER CHANGES

SETTING / GRIND #	51	52	53	54	55	56	57	58	59	60	61	62	63	64	65	66	67	68	69	70	71	72	73	74	75	76	77	78	79	80	81	82	83	84	85	86	87	88	89	90	91										
BASLINE	Z																																																		
SECOND ORDER CHANGES																																																			
BIAS CHANGE							X	X	Y	Y	Z																																								
PROFILE CURVATURE												X	X	Y	Y	Z																																			
LENGTHWISE CURVATURE																	X	X	Y	Y	Z																														
SPIRAL ANGLE CHANGE																						X	X	Y	Y	Z																									
CAM POSITION CHANGE																											X	X	Y	Y	Z																				
THIRD ORDER CHANGES																																																			
BLANK OFFSET																																X	X	Y	Y	Z															
INDEX INTERVAL																																					X	X	Y	Y	Z										
GENERATING CAM NO.																																										X	X	Y	Y	Z					

LEGEND

- X = Machine Setting Change
- Y = 2 times X Setting Change
- Z = Verification Grind

Figure 25. Second and Third Order Grinding Matrix

To accommodate the program schedule, fabrication of the production gear sets for the pilot production program of Phase III was initiated during this Phase. Six pinion and 3 gears were fabricated up to the point of final gear grinding.

### The Measurement Process

Each of the test specimens were assembled in the Gleason test machine and run against their corresponding masters. Transfer tapes for each grind were recorded.

These same test specimens were then measured on the UMM500 measuring machine and the corrective machine settings determined by the Gleason-supplied computer program.

### Results of Corrective Regrinds

To illustrate the effectiveness of the conversion of UMM500 measurements (deviations from nominal value) into delta machine settings for the Gleason grinding machine, four specific grinding machine settings are presented.

- An eccentric angle change of zero degrees and five minutes ( $0^{\circ}5'$ )
- Machine center to back withdrawal of .020 inches
- A pressure angle change of zero degrees and thirty minutes ( $0^{\circ}30'$ )
- A root angle change of zero degrees and twenty minutes ( $0^{\circ}20'$ )

The eccentric angle change  $0^{\circ}5'$  resulted in a maximum deviation of -.0049 inches in the bevel pinion profile geometry as shown in Figure 26. When the pinion was reground to the corrective delta setting calculated by G-Age, this deviation was reduced to -.0014 inches. A second regrind resulted in a maximum deviation of +.0003 inches as shown.

The machine center to back change of .020 inches withdrawal resulted in a maximum deviation of +.0053 inches in the bevel pinion profile geometry as shown in Figure 27. When the pinion was reground to the corrective delta setting calculated by G-Met, the deviation was reduced to +.0009 inches. A second regrind resulted in a maximum deviation of +.0004 inches as shown.

A pressure angle change of  $0^{\circ}30'$  resulted in a maximum deviation of -.0009 inches in the bevel pinion profile geometry as shown in Figure 28. When the pinion was reground to the corrective delta setting calculated by G-Met, this deviation was reduced to -.0004 inches. A second regrind resulted in a maximum deviation of -.0002 inches as shown.

A root angle change of  $0^{\circ}20'$  resulted in a maximum deviation of -.0041 inches in the bevel pinion profile geometry as shown in Figure 29. When the pinion was reground to the corrective delta setting calculated by G-Met, this deviation was reduced to -.0004 inches. A second regrind resulted in a maximum deviation of -.0002 inches as shown.



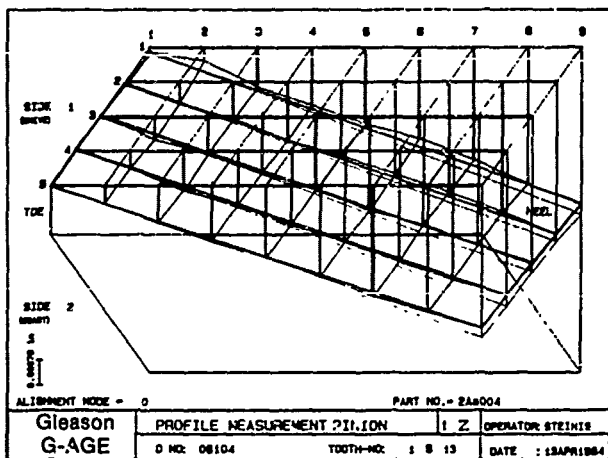

G-Age  
Corrected  
Machine  
Setting

Ecc. Ang. - 0°4'  
Cra. Ang. - 0°1'  
Slid. Base 0°0'  
Root Ang. 0°0'  
Press. Ang. - 0°2'

1<sup>st</sup>  
Corrective  
Grind

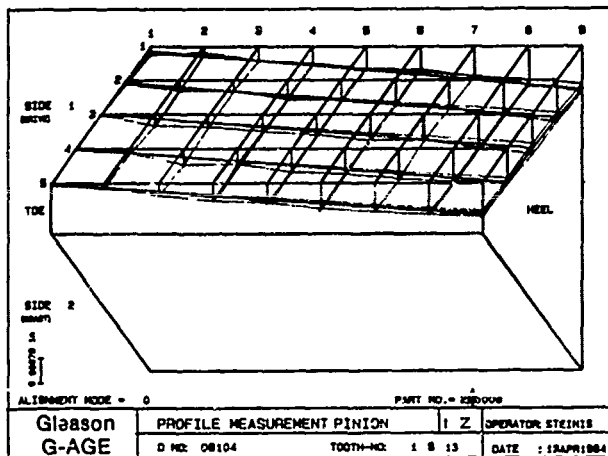

Ecc. Ang. - 0°1'  
Cra. Ang. - 0°0'  
Slid. Base 0°0'  
Root Ang. 0°0'  
Press. Ang. - 0°1'

2<sup>nd</sup>  
Corrective  
Grind

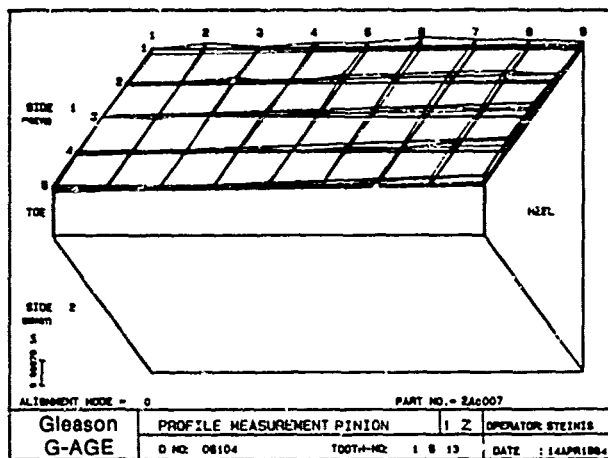

Ecc. Ang. 0°0'  
Cra. Ang. 0°0'  
Slid. Base 0°0'  
Root Ang. 0°0'  
Press. Ang. - 0°1'

Figure 26. Corrective Grinds - Eccentric Angle Deviation

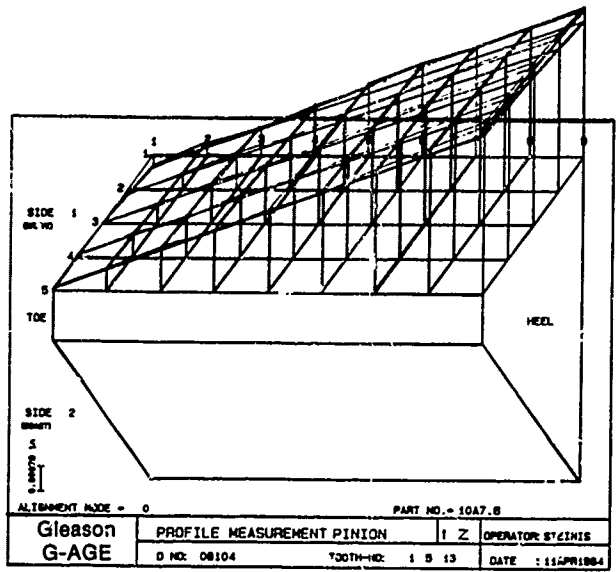

G-Age  
Corrected  
Machine  
Setting

Ecc. Ang. 0°04'  
Cra. Ang. 0°01'  
Std. Base 0°00'  
Root Ang. 0°00'  
Press. Ang. 0°11'

1st  
Corrective  
Grind

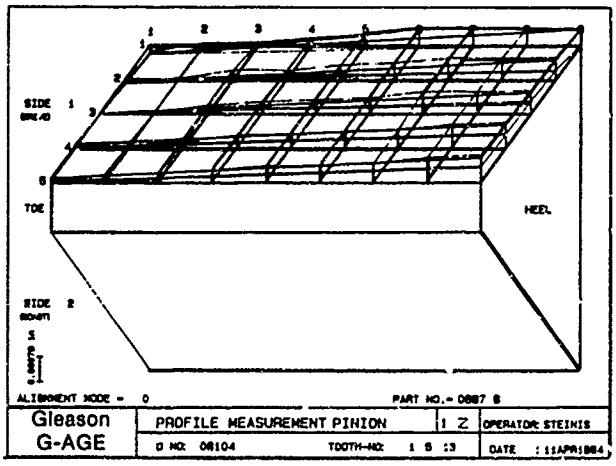

Ecc. Ang. 0°00'  
Cra. Ang. 0°00'  
Std. Base 0°00'  
Root Ang. 0°00'  
Press. Ang. 0°04'

2nd  
Corrective  
Grind

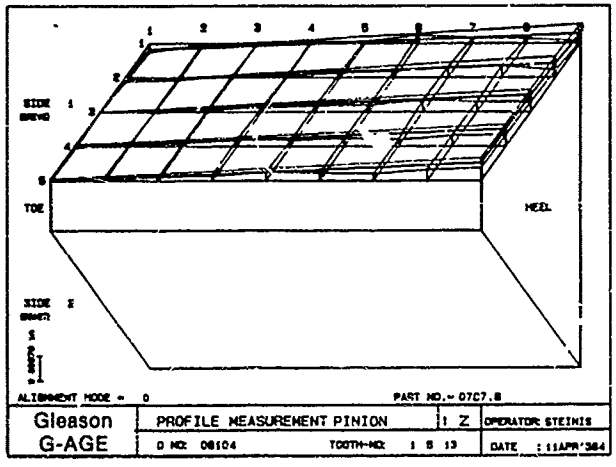

Ecc. Ang. 0°00'  
Cra. Ang. 0°00'  
Std. Base 0°00'  
Root Ang. 0°00'  
Press. Ang. 0°03'

Figure 27. Corrective Grinds - Machine Center to Back Deviation

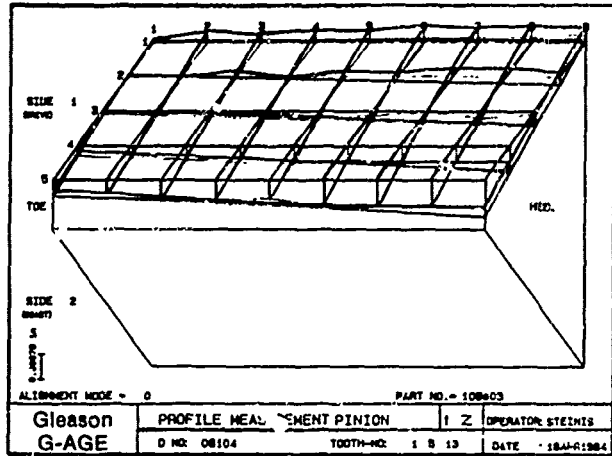

G-Age  
Corrected  
Machine  
Setting

Ecc. Ang. 0°0'  
Cra. Ang. 0°0'  
Slid. Base 0°0'  
Root Ang. 0°0'  
Press. Ang. - 0°16'

1st  
Corrective  
Grind

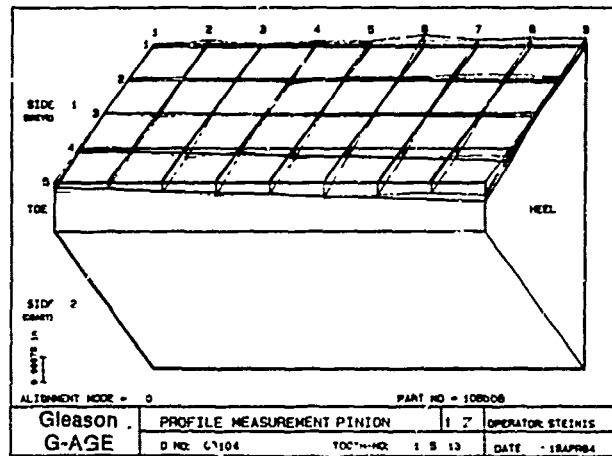

Ecc. Ang. 0°0'  
Cra. Ang. 0°0'  
Slid. Base 0°0'  
Root Ang. 0°0'  
Press. Ang. - 0°8'

2nd  
Corrective  
Grind

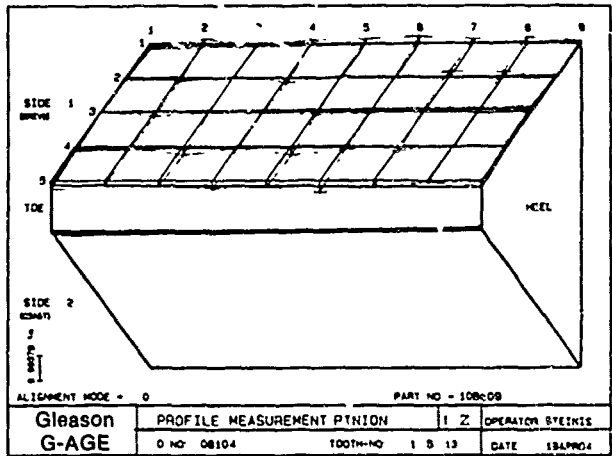

Ecc. Ang. 0°0'  
Cra. Ang. 0°0'  
Slid. Base 0°0'  
Root Ang. 0°0'  
Press. Ang. - 0°4'

Figure 28. Corrective Grinds - Pressure Angle Deviation

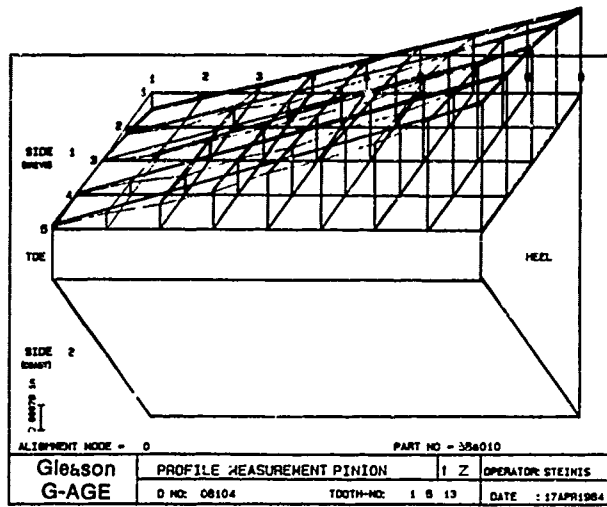

G-Age  
Corrected  
Machine  
Setting

Ecc. Ang. 0°03'  
Cra. Ang. 0°01'  
Slid. Base 0°00'  
Root Ang. 0°00'  
Press. Ang. - 0°17'

1st  
Corrective  
Grind

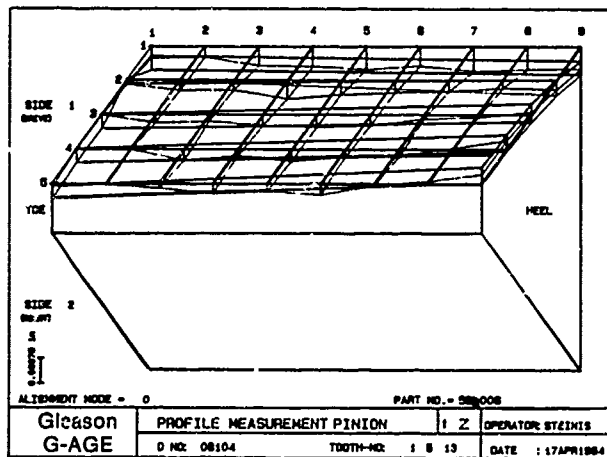

Ecc. Ang. 0°00'  
Cra. Ang. 0°00'  
Slid. Base 0°00'  
Root Ang. 0°00'  
Press. Ang. - 0°08'

2nd  
Corrective  
Grind

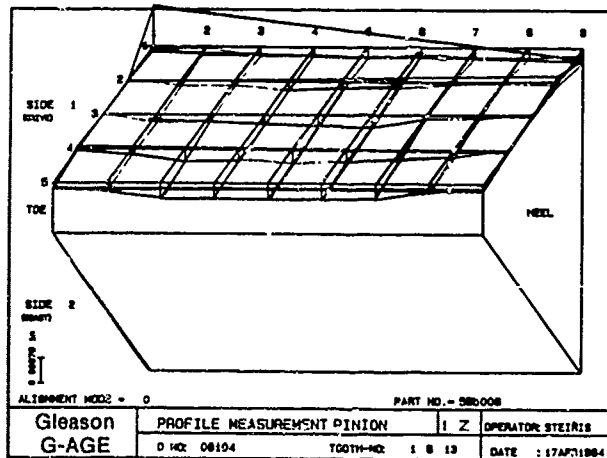

Ecc. Ang. 0°00'  
Cra. Ang. 0°00'  
Slid. Base 0°00'  
Root Ang. 0°00'  
Press. Ang. - 0°02'

Figure 29. Corrective Grinds - Root Angle Deviation

## Discussion of Results

In all four of the above cases, the bevel pinion tooth profile geometry was restored to within acceptable limits in two regrinds using only first order changes. This demonstrated that the G-Age corrective procedure is effective in correcting an out-of-tolerance tooth profile during the production process and can virtually eliminate the need for a final inspection process.

It will be noted that, in some cases, the correction feature of the G-Age program indicated a change in more than one setting when only one was initially disturbed. This illustrates the fact, previously mentioned, that a combination of two or more moves in the Gleason grinder may produce results similar to a single move. If the correction program can be faulted, perhaps it can be said that it does not necessarily take the most direct path to a solution.

It should be mentioned, at this point, that the G-Age program, sophisticated as it is in its present form, is undergoing changes and modifications to improve its effectiveness. Later versions, for example, will include second order changes as well as first order changes.

## Establishment of Tolerance Limits

Based upon the results of the efforts of Phases I and II and the experience accumulated of the Zeiss UMM500 multi-axis measuring machine, preliminary tolerance levels have been established for the selected BLACK HAWK bevel gear set. These are shown in Table 5. Each grid point location has a specific tolerance. If these limits are connected by straight lines the tolerance envelope of Figure 30 is derived. This could be used in the form of a transparent overlay in the inspection process.

TABLE 5. ZEISS FLANK FORM TOLERANCE LIMITS

COORDINATE POSITION

		1-1	1-3	1-5	5-1	5-3	5-5	9-1	9-3	9-5
Class 13	1" F.W.	3	1	3	2	0	2	3	1	3
Class 13	2" F.W.	3.5	1.5	3.5	2	0	2	3.5	1.5	3.5
Class 13	3" F.W.	4.5	2	4.5	2.5	0	2.5	4.5	2	4.5
Class 13	4" F.W.	5	5	2.5	2.5	0	2.5	5	2.5	5
Class 12	1" F.W.	4	1.5	4	2.5	0	2.5	4	1.5	4
Class 12	2" F.W.	4.5	2	4.5	2.5	0	2.5	4.5	2	4.5
Class 12	3" F.W.	5.5	2.5	5.5	3	0	3	5.5	2.5	5.5
Class 12	4" F.W.	6	3	6	3	0	3	6	3	6
Class 11	1" F.W.	5	2	5	3	0	3	5	2	5
Class 11	2" F.W.	5.5	2.5	5.5	3	0	3	5.5	2.5	5.5
Class 11	3" F.W.	6.5	3	6.5	3.5	0	3.5	6.5	3	6.5
Class 11	4" F.W.	7	3.5	7	3.5	0	3.5	7	3.5	7

Tolerance in ten thousandth of an inch.

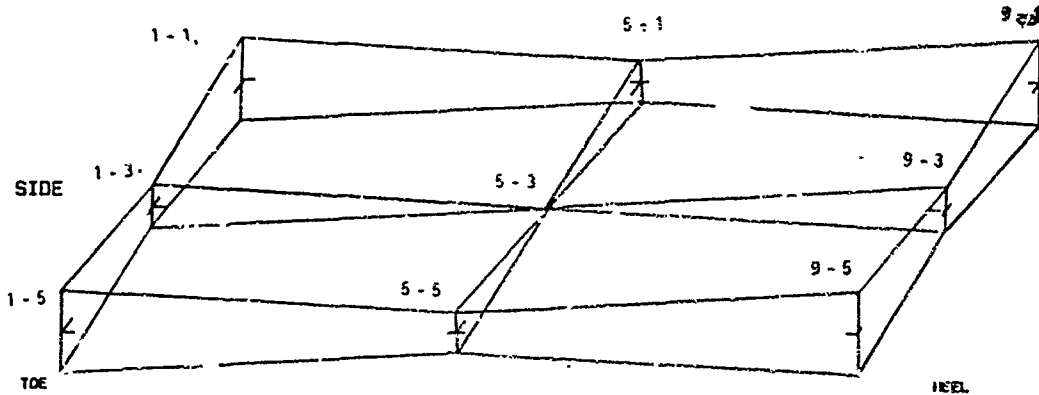

Figure 30. Overlay Tolerance Chart

## PILOT PRODUCTION AND TEST PROGRAM

To verify that the improved spiral bevel gear manufacturing and inspection techniques developed in Phases I and II does in fact produce an acceptable spiral bevel gear with the desired tooth profile, six pinions and 3 gears were manufactured from the raw forgings, heat treated, case hardened, and final ground to the production configuration using the Zeiss UMM500 as the primary in-process and final inspection control.

### Fabrication of Pilot Production Test Gears

Three gearbox-sets (two pinions and one gear) were ground on the Gleason grinder, using the Automated Inspection Process as the inspection control. These test gears differ from the gear test specimens used in Phases I and II in that they conform to the production requirements dimensionally in all respects with the exception of the tooth geometry as described below. The three gear members were ground to duplicate the flank form of the appropriate Reference Master Control Gear within the preliminary tolerances established in Phase II and shown in Table 5 and Figure 30. The six pinions were ground according to the following requirements.

### Inspection Results

#### Configuration 1.

Two pinions were ground to duplicate the same flank form of the Reference Master Control gear within the flank form tolerance of Table 5. This configuration thus represents the production configuration produced using the automated inspection/control process. The Gleason test machine patterns and the Zeiss UMM500 measurements are shown in Figure 31.

#### Configuration 2.

Two pinions were ground with a  $0^{\circ} 07'$  decrease in pressure angle. The corresponding Gleason taped patterns and the flank form measurements are shown in Figure 32. The Zeiss UMM500 measured data shows a .0004-inch material increase in the addendum of the tooth along the top band. This value is outside the established preliminary flank form tolerance in this area. The Gleason test machine pattern, although slightly higher on the tooth, did meet the production requirements and would be accepted even by the most discriminating inspector.

#### Configuration 3.

The last two pinions were ground with a lengthwise profile curvature change. This was accomplished by a .040-inch increase in the grinding wheel diameter (an .020 side dresses radial change). The Zeiss flank form measurements (Figure 33) shows a .0007-inch arch at the center of the tooth. The Gleason test machine pattern showed a total V-only check of .025 as compared to .013 on the master gears. This variance is beyond acceptable limits and the pinion would have been rejected.

Q's 10-26-84

PATTERN TAPE RECORD

HAND OF SPIRAL  RIGHT  LEFT      TESTER NO. 523-2  
 NORM. B/L TOL. 0.008 MASTER B/L 0.020 ACTUAL TOTAL B/L 0.027 ACTUAL B/L 0.007  
 MASTER GEAR # 70351-08114 T.199 38035-08104-1821101 3/N.0002  
 CENTRAL BEARING - DRIVE

CENTRAL BEARING - COAST	
V ONLY TOE	
V =	ACTUAL Y = <u>-0.005</u>
V ONLY HEEL	
V =	ACTUAL Y = <u>-0.012</u>
V & H TOE CHECK	

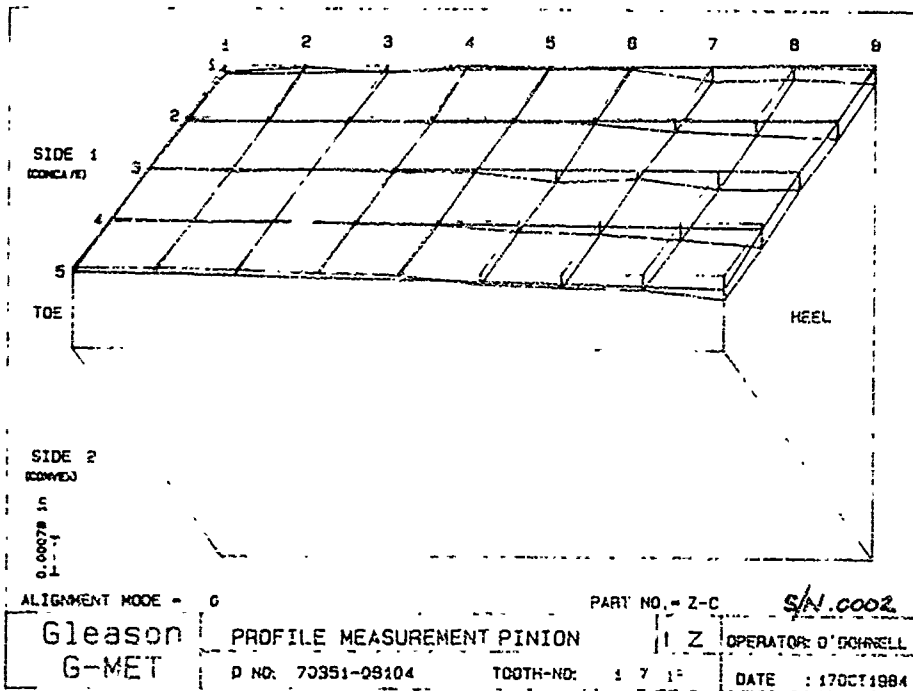

Figure 31. Test Configuration 1 Measurements



PATTERN TAPE RECORD

015 12-24-74

HAZD OF SPIRAL  RIGHT  LEFT

TESTER NO. 523-2

NOM. S/L TOE .0014 MASTER S/L .000 ACTUAL TOTAL S/L .0065 ACTUAL S/L .0055

MASTER GEAR # 70351-08114 F.1922-200 70351-0804-00 PINION S/N 203

CENTRAL BEARING - DRIVE

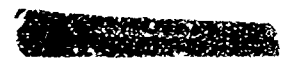

CENTRAL BEARING - COAST

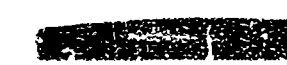

V ONLY TOE

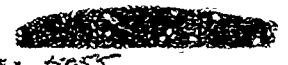
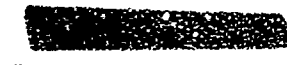

V =

ACTUAL V = .0055

V ONLY HEEL

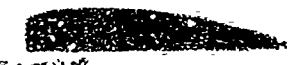
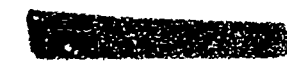

V =

ACTUAL V = .006

V & H TOE CHECK

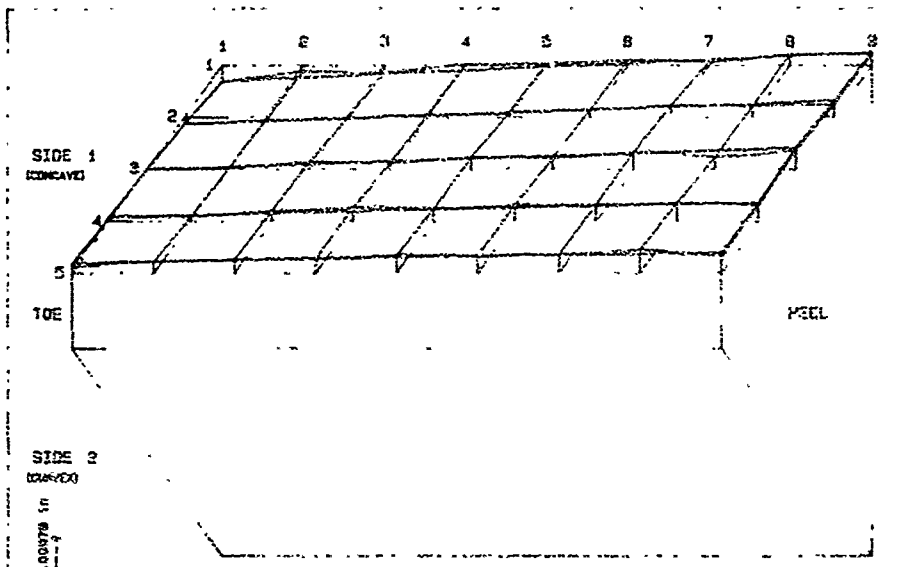







ALIGNMENT MARK = 0 PART NO. = 2-000

Gleason G-MET	PROFILE MEASUREMENT PINION	1 2	OPERATOR: STEINIS
D NO: 70351-08104	TOOTH NO: 1 7 15	DATE : 25 OCT 1984	

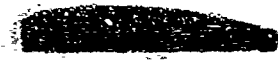
Figure 32. Test Configuration 2 Measurements

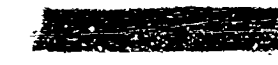
**PATTERN TAPE RECORD** CIS 10-26-84

DIRECTION:  RIGHT  LEFT      TESTER NO. 503-2  
 MASTER B/L 020    ACTUAL TOTAL B/L 026    ACTUAL B/L 006  
 PART NO. 20301-08104    TOOTH NO. 17    DATE 28 OCT 1984    PIRTON  
 SERIAL NO. 3117    S/N. 005

CENTRAL SCANNING - DRIVE	
	
CENTRAL SCANNING - COAST	
	
V ONLY FACE	
	
V =	ACTUAL V = <u>+007</u>
V ONLY REEL	
	
V =	ACTUAL V = <u>-016</u>
V & H TOE CHECK	

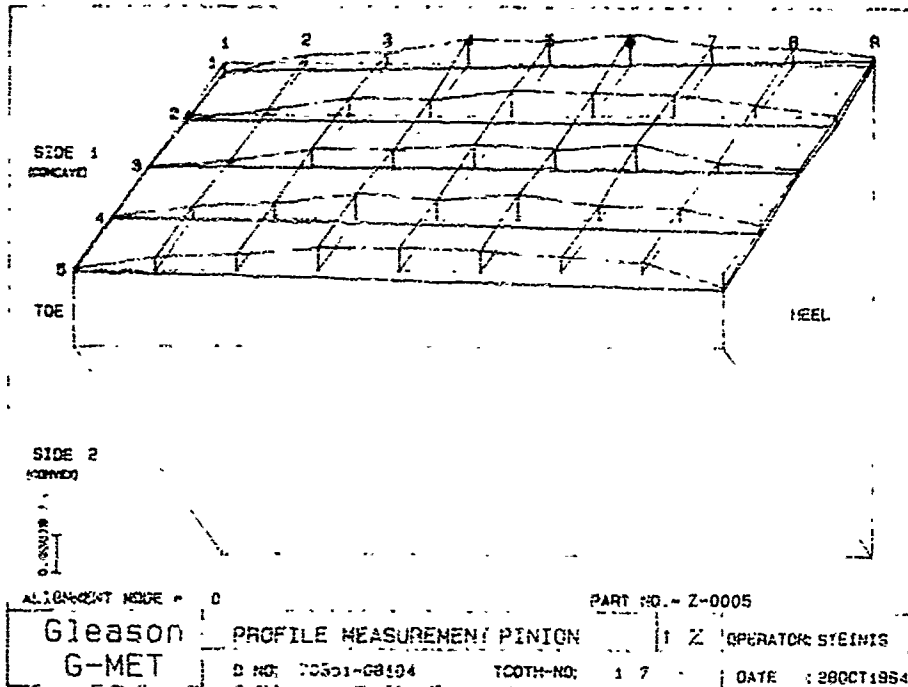

Figure 33. Test Configuration 3 Measurements

## H-60 Main Test Facility

The H-60 main transmission bench test facility is a regenerative power test stand that simultaneously tests two gearboxes. Both transmissions experience the correct loading, but while one gearbox (position #1) turns in the normal direction, the other gearbox (position #2) turns in the reverse direction. The reverse rotation transmission incorporates a modified lubrication pump installation to account for its reverse rotation. Since lubrication is provided both in and out of mesh, no other changes to the reverse rotation transmission are necessary.

In the main transmission regenerative power test stand there are three mechanical loops (LH input, RH input, and Tail Take Off) consisting of the test gearboxes (2), commercial gearboxes (6), and interconnecting shafts. These mechanical closed loops can be independently torqued while under rotation creating a regenerating flow of power through the test gearboxes. The loops can be torqued to simulate powers to the gearbox that are continuously variable from zero to 150% of the design ratings of the H-60 main transmission. Speed is continuously variable from zero to 110% normal rated speed.

### Acceptance Test Program

After final grinding, the test gears were assembled into the test main gearbox, shown in Figure 34, and a production acceptance test conducted on each configuration.

The ATP is an integrated gearbox system test run in the UH-60 main gearbox test facility. It is used to qualify the gearbox before it is installed on the aircraft. The acceptance test power spectrum shown in Table 6 encompasses the full range of powers expected in service.

TABLE 6  
ATP POWER SPECTRUM

<u>L/H Input</u>	<u>Power (SHP)</u>		<u>Duration (Minutes)</u>
	<u>R/H Input</u>	<u>TTO</u>	
400	400	25	5
700	700	85	15
1000	1000	170	10
1250	1250	230	5
700	700	85	5
1400	1400	200	3

### Test Results

After completion of the ATP test, the test gearbox was disassembled to the level necessary and the test gear set removed for examination. The following criteria was used for evaluation.



Figure 34. H-60 Test Main Gearbox

- The size and shape of the composite bearing pattern.
- The presence of any signs of surface distress, or excessive concentrations of load, such as scoring, surface pitting or chipping.
- General conditions and appearance of the working surface compared to previous production runs.

#### Test 1

Both gears and pinion of this configuration looked exceptionally good compared with previous production runs. The size and location of the pattern were good and there were no signs of surface distress anywhere on the tooth flank. Figure 35 shows the condition of the test pinion after the test.

#### Test 2

This configuration which was ground with a slight pressure angle variance showed moderate scoring along a major portion of the tooth flank on both pinion



Figure 35. Results of Test 1

and gear. This is an unacceptable condition and is cause for rejection. Gear tooth scoring is characteristic of excessive heat generation in the mesh caused either by degeneration of the oil film between the contacting surfaces or by excessive concentration of load. In this case the concentration of load in the tooth addendum of the pinion precipitated the scoring which rapidly spread out over the tooth flank resulting in the condition shown in Figure 36.

### Test 3

The pinion teeth in this configuration were ground with excessive length-wise curvature, concentrating the load in the center of the tooth. These test gears exhibited extensive scoring similar to those of Test 2 and for the same reasons. See Figure 37.

### Discussion of Results

This verification test demonstrated the sensitivity of this selected spiral bevel gear set to small changes in machine settings, and particularly to changes which affect load distribution. a small distribution of load intensity over the tooth flank is probably the primary contribution to gear scoring and surface breakdown in spiral bevel gears.

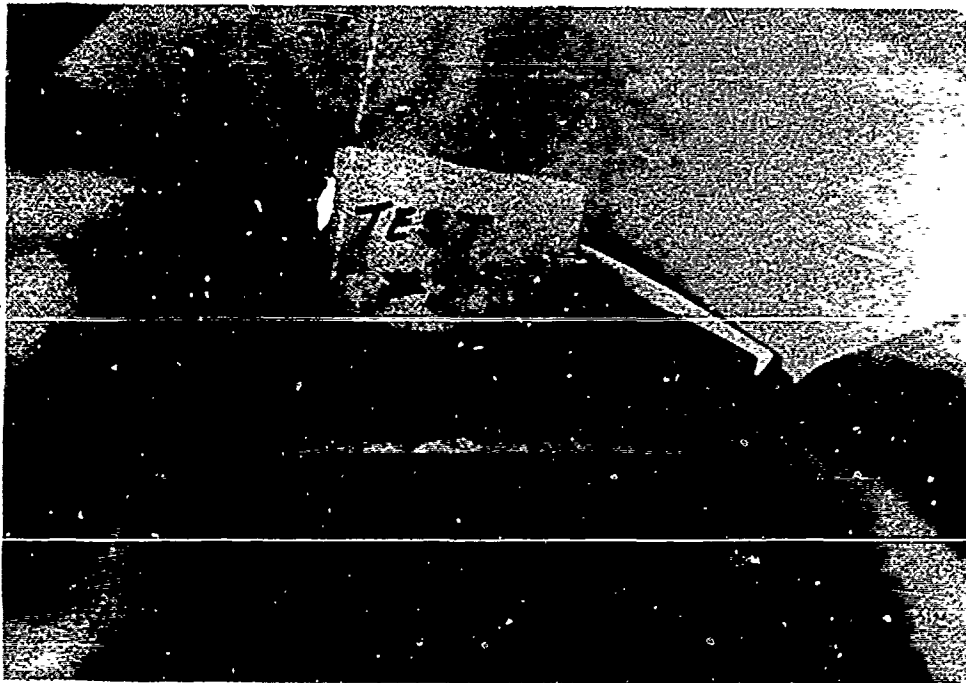

Figure 36. Results of Test 2

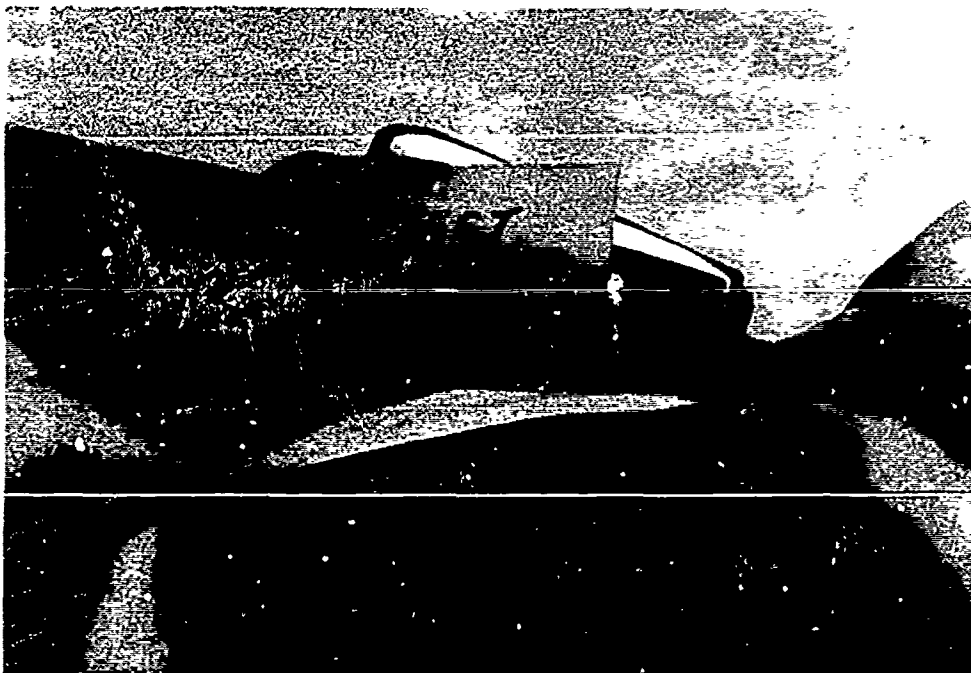

Figure 37. Results of Test 3

A third conclusion that can be made from these test results is that the proposed tolerance limits have proven to be a good starting point since the modified pinions of both scored gear sets were outside the tolerance band. As experience with this inspection system accumulates, the tolerance limits can be fine-tuned with the objective of obtaining a reasonable tolerance which will preclude scoring during the ATP.

Also demonstrated in this test was the ability of the improved inspection method to control the surface profile to within rather narrow limits compared to the taped pattern method. This was evidenced by the fact that the gears of Test 2, which were acceptable by the old criteria, resulted in a scored tooth and a scrap gear set. This pinion would not have passed the improved inspection criteria.

## ECONOMIC COST ANALYSIS

The projected savings in inspection and manufacturing times realized from the installation of the improved measurement process described herein was estimated to be 7 3/4 hours per gear. The following analysis shows the equivalent dollar savings and resulting cash flow over a five-year period.

### Basis for Economic Analysis

The data upon which the economic impact of the improved bevel gear production process is based is shown in Table 7. It assumes that 50 percent of the BLACK HAWK spiral bevel gears are produced at Sikorsky Aircraft, and estimates the benefits derived solely from that production over a five-year period.

### Income/Expense Statement

Table 8 lists the annual dollar savings and costs associated with the new inspection method in each of the five years. Table 9 presents the annual and cumulative cash flow situation and shows the payback percentages.

### Results

Based upon the cash flow picture presented in Table 9, the calculated breakeven point for this investment is 1.56 years. The calculated present worth, with an assumed acceptable rate of return of 23 percent, is \$320,700. The internal rate of return for zero present worth is 16.7, 39.1, 49.7, and 55.2 respectively for years 2, 3, 4, and 5.



TABLE 7. BASIS FOR ECONOMIC ANALYSIS

No. of aircraft - BLACK HAWK, SEAHAWK, spares					
Year	1	2	3	4	5
A/C	158	158	163	163	163

17 bevel gears per aircraft  
 50% of gears produced at Sikorsky  
 7.75 hrs saved per gear  
 Labor rate \$16.73 per hour (1986 dollars)  
 Master gear savings 12 parts @ \$8000 ea.  
 15% reduction in scrap  
 Tear down and rebuild savings - 32 hrs per A/C  
 Depreciation

Year	1	2	3	4	5
%	15	22	21	21	21

Tax bracket 46%  
 Sales tax 7.5%  
 Maintenance costs 3%  
 Misc software \$1200

TABLE 8. INCOME/EXPENSE STATEMENT

	Base yr 0	Base yr 1	Base yr 2	Base yr 3	Base yr 4	Base yr 5
<b>Savings:</b>						
Labor hrs		180,466	180,466	186,121	186,121	186,121
Materials		237,000	237,000	244,500	244,500	244,500
Overhead		96,000				
Manpower						
Total savings		513,466	417,466	430,612	430,612	430,162
<b>Costs:</b>						
Depreciation	67,500	99,000	94,500	94,500	94,500	94,500
Property tax		14,700	12,716	9,805	7,027	4,248
Maintenance		15,000	15,000	15,000	15,000	15,000
Perishable tls						
Supplies						
Sales tax	37,500					
Miscellaneous						
Total costs	105,000	128,700	122,215	119,305	116,527	19,248
Gross margin	(105,000)	384,766	295,251	311,316	314,094	411,373
<b>Start-up expenses:</b>						
Hrly labor						
Slry labor						
Tooling						
Rearrangement						
Miscellaneous		1,200				
Total expenses		1,200				
Pre-tax prof/loss	(105,000)	384,766	295,251	311,316	314,094	411,373
Aft-tax prof/loss	(56,700)	207,126	159,435	168,111	169,611	222,141

TABLE 9. CASH FLOW AND PAYBACK ANALYSIS

	Base yr 0	Base yr 1	Base yr 2	Base yr 3	Base yr 4	Base yr 5
Pre-tax prof/loss	(105,000)	383,566	295,251	311,316	314,094	411,373
Aft-tax prof/loss	(56,700)	207,126	159,435	168,111	169,611	222,141
Depreciation	67,500	99,000	94,500	94,500	94,500	
Capital expense	(500,000)					
Residual value						50,000
I.T.C.	40,000					
Total	(392,500)	99,000	94,500	94,500	94,500	50,000
Annual cash flow	(449,200)	306,126	253,935	262,611	264,111	272,141
Cumulative cash		(143,074)	110,861	373,472	637,583	909,724
Pres. val @ 23%	320,706		16.70	39.10	49.70	55.20
DCRR						

## CONCLUSIONS

1. An improved inspection method for spiral bevel gears was defined and demonstrated for both in-process and final inspection.
2. The method permits quantitative evaluation of bevel gear tooth profiles and eliminates the subjective accept/reject decision making which is characteristic of the present contact pattern method.
3. The defined process automatically calculates grinding machine setting changes necessary to correct an out-of-tolerance profile, in two grinding cycles.
4. Manufacturing and inspection time for spiral bevel gears is reduced by 7 3/4 hours per gear resulting in significant cost savings.
5. The entire tooth contact surface can be measured and controlled rather than a localized contact area.
6. The measuring machine has the capability of measuring blank dimensions as well as tooth index and spacing errors.
7. The process produces permanent digital and graphical inspection records for each gear measured.
8. The need for maintenance and inspection of primary and sub-ties hard master gears is eliminated.
9. The coordinate measurement machine replaces three single-purpose gear measurement machines and has additional universal capability which can be exploited in areas other than gear measurement.
10. The improved inspection system utilizing the multi-axis coordinate measuring machine will produce higher-quality gears with fewer anomalies in acceptance test results.

APPENDIX I  
PROCESS SPECIFICATION  
AUTOMATED INSPECTION AND PRECISION GRINDING  
OF SPIRAL BEVEL GEARS

1. SCOPE

1.1 Scope. This specification prescribes a manufacturing and inspection process for spiral bevel gear tooth profile geometry using a multi-axis coordinate measuring machine. It also describes the measurement technique using the Zeiss model UMM 500 and defines the quality requirements and inspection tolerances to be used in the interpretation of the measurement data.

1.2 Classification. The procedures and tolerances prescribed herein shall apply to aircraft-quality primary-drive spiral bevel gears, conforming approximately to AGMA classes 11, 12, and 13.

2. APPLICABLE DOCUMENTS

2.1 Referenced Documents. The following documents of the issue in effect on the date of invitation for bids or request for proposal, form a part of this specification to the extent specified herein.

ZEISS DOCUMENTATION

COMET II, Coordinate Metrology Software.  
Operating Instructions.

GLEASON DOCUMENTATION

G-AGE Users Manual  
Hypoid Generator Operating Instructions  
Hypoid Grinder Operating Instructions  
Application Engineering On-Line Computer  
Service Instructions

3. REQUIREMENTS

3.1 Equipment. The following equipment is required for the measurement process described below.

ZEISS UNIVERSAL MEASURING MACHINE UMM 500

Basic machine, including CNC, Antivibration system, Interface,  
Calibration sphere, starprobe, Probe kit, and Peripheral station.

Optical equipment with Probe kit for gear measurement.

Rotary table, RT05, with Interface/and Expander

Hewlett Packard Desktop Computer System including HP 9836 calculator,  
HP 9862A X-Y plotter and impact line printer

## SOFTWARE

COMET II	Zeiss Universal Measuring Program with CNC Learn Programming
G-AGE	Gleason Spiral Bevel Gear Measuring Program with Misalignment Compensation on Rotary Table and Corrective Machine Setting Feature

3.2 Required procedures and operations. The technique outlined herein uses the Zeiss Model UMM 500 Coordinate Measuring Machine in conjunction with an advanced Gleason software package that permits rapid three-dimensional mapping of a spiral bevel gear tooth profile and quantitative comparison of surface coordinates with stored nominal values. The technique features a means for rapidly calculating corrective grinding machine settings for controlling the tooth profile within specified tolerance limits.

3.2.1 Determination of nominal values. The representative nominal values can be derived either by digitization of an existing Master Gear which has the desired profile, or from theoretical values calculated from the final grinding machine settings used to produce the Master Gear profile.

The theoretical flank form coordinate values are obtained from a computer data file. This file is developed by first running the following Gleason computer programs.

- Dimension Sheet
- TCA (Tooth Contact Analysis)
- Cutting and Grinding Summary
- Tooth Surface Point Generator Program (T801)

To transfer the flank form data to the HP 9836 computer, the operator must use the Gleason T836 program.

A modem and phone hook-up are required for this computer data link. Refer to the Gleason G-AGE user's manual. The nominal data can also be purchased from the Gleason Works in a disc format.

If the theoretical nominal data are known, the X, Y, and Z coordinates and unit vector normals can be entered into the computer manually for each grid point.

3.2.2 Measurement of spiral bevel gear teeth. The operator should be completely familiar with the Zeiss coordinate measuring machine, the Zeiss COMET software, the Gleason G-AGE software, and the Gleason spiral bevel gear system. Instructions and training on the Zeiss UMM 500 and the COMET program are available from Carl Zeiss, Inc., Thornwood, NY. Training on the Gleason system and the G-AGE program is available from the Gleason Machine Division of the Gleason Works, Rochester, NY.

The work piece is positioned on the machine bed or on the Rotary Table using the COMET II software and observing good machine practices. Some guidelines are:

Use the same tooling points as used on the Gleason grinder and/or generator

Do not use proof diameters because they may not be accurate

The gear axis should be in the vertical plane (Z axis).

If stored theoretical data is not available or applicable, the required nominal values can be taken from an existing Master Gear. First the corner points of the surface grid are probed manually or they can be calculated, for a given edge distance, using the formulas in Table I. After the grid density is chosen, the measurement process proceeds automatically.

For the case where the nominal values have already been generated and stored in the computer, and a production gear positioned on the machine; the measurement process is automatic. After initial contact has been made, the probe is directed by the computer to each grid point, measures the coordinates, and compares the surface normal at that location to its nominal value. When each tooth is measured, the probe automatically travels to the next designated tooth.

The measurement data is presented both as a three-dimensional error plot and as a digital table of deviations from nominal values.

3.2.3 Comparison with nominal values. The corrective feature of the Gleason G-AGE computer program will only correct first order changes. The program will print out the delta grinding machine settings required to correct the profile. The program does not always correct the delinquent machine setting and in certain cases the recommended setting changes can affect other areas of the tooth. For example:

A pinion ground with a machine-center-to-back error will be directed to use the eccentric angle and pressure angle to correct the first order variance.

A gear ground with a machine-center-to-back error will use the eccentric angle and the root angle to correct the variance.

In the case of the gear, the root angle change can be detrimental to stock removal in the root of the tooth. In both cases it may require a second order lengthwise curvature change to correct the total flank form.

TABLE I. FORMULA FOR CORNER POINTS

1	Mounting Distance	19	$\text{Sin}(6) \cdot (17)$
2	Zero Point (Z Axis)	20	$(5) - 2 \cdot (9)$
3	Pitch Apex to Crown	21	$\text{Cos}(6) \cdot (20)$
4	Crown Diameter	22	$\text{Sin}(6) \cdot (20)$
5	Face Width	23	$\text{Cos}(7) \cdot (20)$
6	Face Angle	24	$\text{Sin}(7) \cdot (20)$
7	Root Angle	25	$(4)/2$
8	Working Depth	26	$(1) - (3)$
9	FW $\Delta$	27	$A-X = (25) - (14) - (18) - (24)$
10	WD $\Delta$		
11	$\text{Cos}(6) \cdot (9)$	28	$A-Z = (26) + (16) - (19) + (23) - (2)$
12	$\text{Sin}(6) \cdot (9)$	29	$B-X = (25) - (14) - (22)$
13	$\text{Cos}(6) \cdot (10)$	30	$B-Z = (26) + (16) + (21) - (2)$
14	$(13) + (12)$	31	$C-X = (25) - (14)$
15	$\text{Sin}(6) \cdot (10)$	32	$C-Z = (26) + (16) - (2)$
16	$(11) - (15)$	33	$D-X = (25) - (14) - (18)$
17	$(8) - 2 - (10)$	34	$D-Z = (26) + (16) - (19) - (2)$
18	$\text{Cos}(6) \cdot (17)$		

Note: See Figure 1 for identification of points A, B, C, and D; and axes X, Y, and Z.



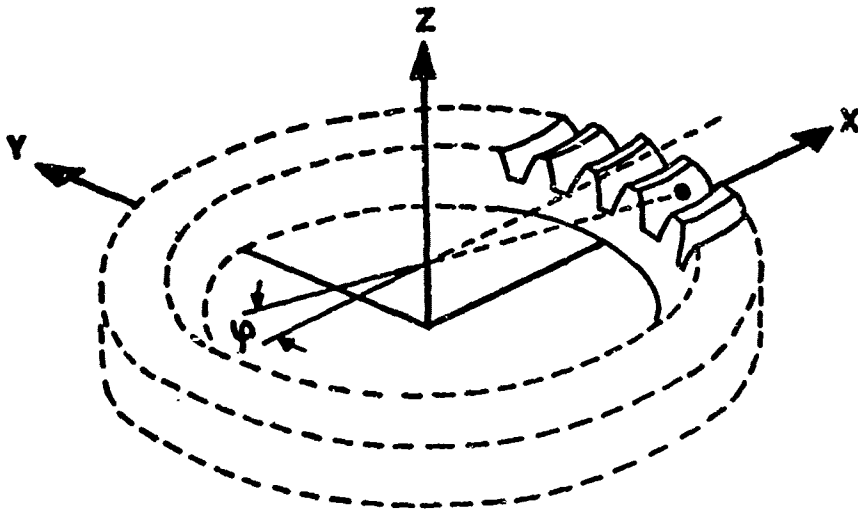
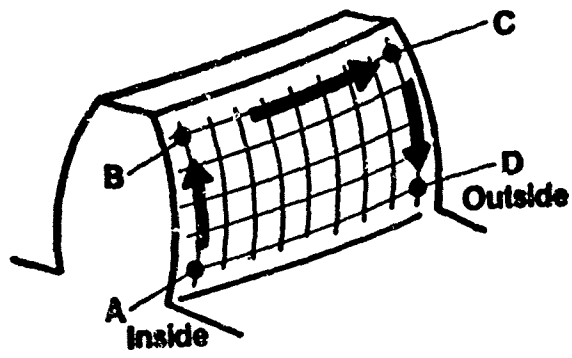

Figure 1. Definition of Axes and Corner Points

3.3 Recommended procedures and operations. The three-dimensional plot of the variances from nominal values, in some cases, will suggest first order and limited second order changes which can be made without the benefit of the G-AGE correction program.

3.3.1 Pressure angle variance (First Order). The pressure angle variance can be determined by evaluating the measured data grid points at 5-1, 5-3 and 5-5 (Ref. Figure 2) of a 9 x 5 measured grid. If the total variation were .0005 over a measured depth of .4 the correction to the machine pressure angle would be  $0.0716^\circ$  ( $0^\circ 04.2'$ ). This delta correction can be calculated using the following formula.

$$PA_c = \text{TAN}^{-1} \frac{Ec}{Md}$$

PAc = Pressure angle change  
 Ec = Effective change  
 Md = Measuring depth (see NoteA)

NOTE A: The measured depth can be derived from the Gleason computer program Theory/T801 if the measuring data is using theoretical data or can be derived from the program used to calculate the height and radius for the four corner points.

The direction of the pressure angle change can be determined by referring to the Gleason Hypoid Grinder Operating Instruction manual.

3.3.2 Spiral angle variance (First Order). The spiral angle variance can be determined by evaluating the measure data at grid points 1-3, 5-3 and 9-3 (Ref. Figure 2) of a 9 x 5 measured grid. If the total variation were .001 over a face width of 3 inches and a  $25^\circ$  spiral angle, the eccentric angle correction would be  $.01854^\circ$  ( $0^\circ 01.1'$ ). The delta correction can be calculated using the following formula.

$$E/A_c = \text{TAN}^{-1} \frac{Ec}{FW - (FW \Delta \cdot 2) \frac{1}{\text{Cos } S/A}}$$

E/Ac = Eccentric angle change  
 FW = Face width  
 FW Δ = Face width delta (see Note B)  
 S/A = Spiral angle  
 Ec = Effective change

NOTE B: The face width delta is derived from the Gleason computer program, Theory/T801 if the measuring data is using theoretical data or can be derived from the program used to calculate the height and radius for the four corner points.

The direction of the eccentric angle change can be determined by referring to the Gleason Hypoid Grinder Operating Instruction manual.

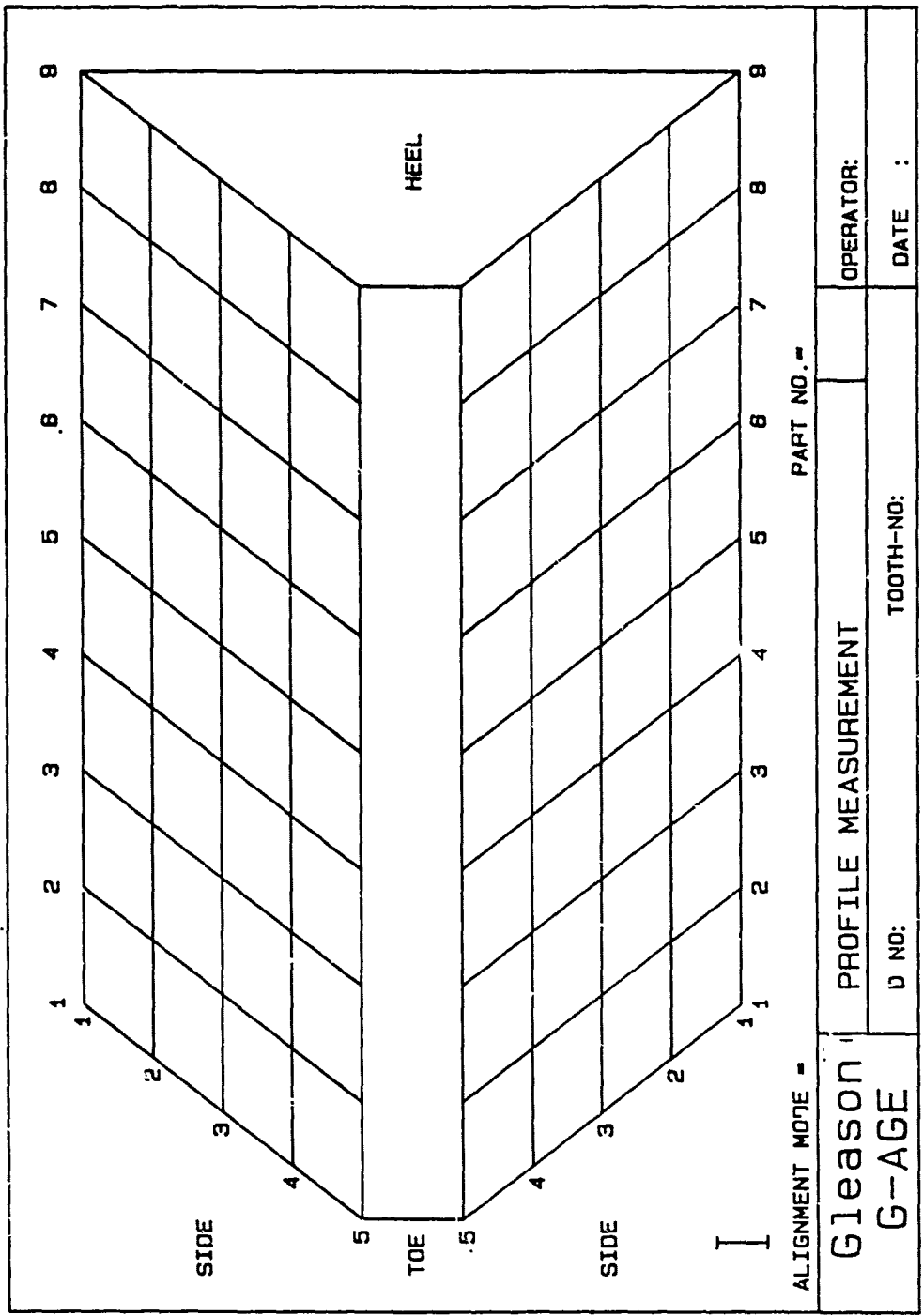

Figure 2. Definition of Grid Points

3.3.3 Lengthwise curvature change (Second Order). The lengthwise curvature variance can be determined by evaluating the measured data at 1-3, 2-3, 3-3, 4-3, 5-3, 6-3, 7-3, 8-3, and 9-3 (Ref. Figure 2) of the 9 x 5 measured grid. If the measured line in the lengthwise direction is a concave or convex curve it requires a wheel diameter change. If the arc height of the curve is .001, the change to the side dresser radial would be .041. The delta correction can be calculated using the following formula.

$$FW_m = FW - (FW \Delta \bullet 2) \frac{1}{\cos S/A}$$

$$h = R_w - 1/2 \sqrt{4 R_w^2 - FW_m^2}$$

$$H = h - A_h$$

$$r = \frac{FW_m^2 + 4H^2}{8H}$$

$$SD_{R\Delta} = R_w - r$$

$SD_R$   $\Delta$  = Side dresser radial  $\Delta$  change

$R_w$  = Wheel radius

$FW$  = Face Width

$A_h$  = Arc height (Zeiss)

$FW \Delta$  = Face width delta

$S/A$  = Spiral angle

The direction of the side dresser radial change can be determined by referring to the Gleason Hypoid Grinder Operating Instruction manual.

#### 4. QUALITY ASSURANCE PROVISIONS

4.1 Responsibility for inspection. Unless otherwise specified in the contract or order, the gear manufacturer or supplier is responsible for the performance of all inspection requirements as specified herein.

4.2 Monitoring procedures for equipment used in process. The measuring equipment used in this process specification shall be maintained in a environmentally controlled area and shall be checked and calibrated periodically to assure process control.

4.3 Conformity requirements. All finished ground gear tooth variances from nominal values shall not exceed those values shown on the "Zeiss Flank Form Tolerance Chart" (see Table II). The tolerance chart has three class categories, Class 11, 12, 13. A 5 x 9 grid shall be used for measurement of flank form. Three teeth approximately 120° apart on each gear. An overlay plot as shown in Figure 3 can be used as a guide for judging acceptance.

TABLE II. ZEISS FLANK FORM TOLERANCE LIMITS

COORDINATE POSITION

		1-1	1-3	1-5	5-1	5-3	5-5	9-1	9-3	9-5
Class 13	1" F.W.	3	1	3	2	0	2	3	1	3
Class 13	2" F.W.	3.5	1.5	3.5	2	0	2	3.5	1.5	3.5
Class 13	3" F.W.	4.5	2	4.5	2.5	0	2.5	4.5	2	4.5
Class 13	4" F.W.	5	5	2.5	2.5	0	2.5	5	2.5	5
Class 12	1" F.W.	4	1.5	4	2.5	0	2.5	4	1.5	4
Class 12	2" F.W.	4.5	2	4.5	2.5	0	2.5	4.5	2	4.5
Class 12	3" F.W.	5.5	2.5	5.5	3	0	3	5.5	2.5	5.5
Class 12	4" F.W.	6	3	6	3	0	3	6	3	6
Class 11	1" F.W.	5	2	5	3	0	3	5	2	5
Class 11	2" F.W.	5.5	2.5	5.5	3	0	3	5.5	2.5	5.5
Class 11	3" F.W.	6.5	3	6.5	3.5	0	3.5	6.5	3	6.5
Class 11	4" F.W.	7	3.5	7	3.5	0	3.5	7	3.5	7

Tolerance in ten thousandth of an inch.

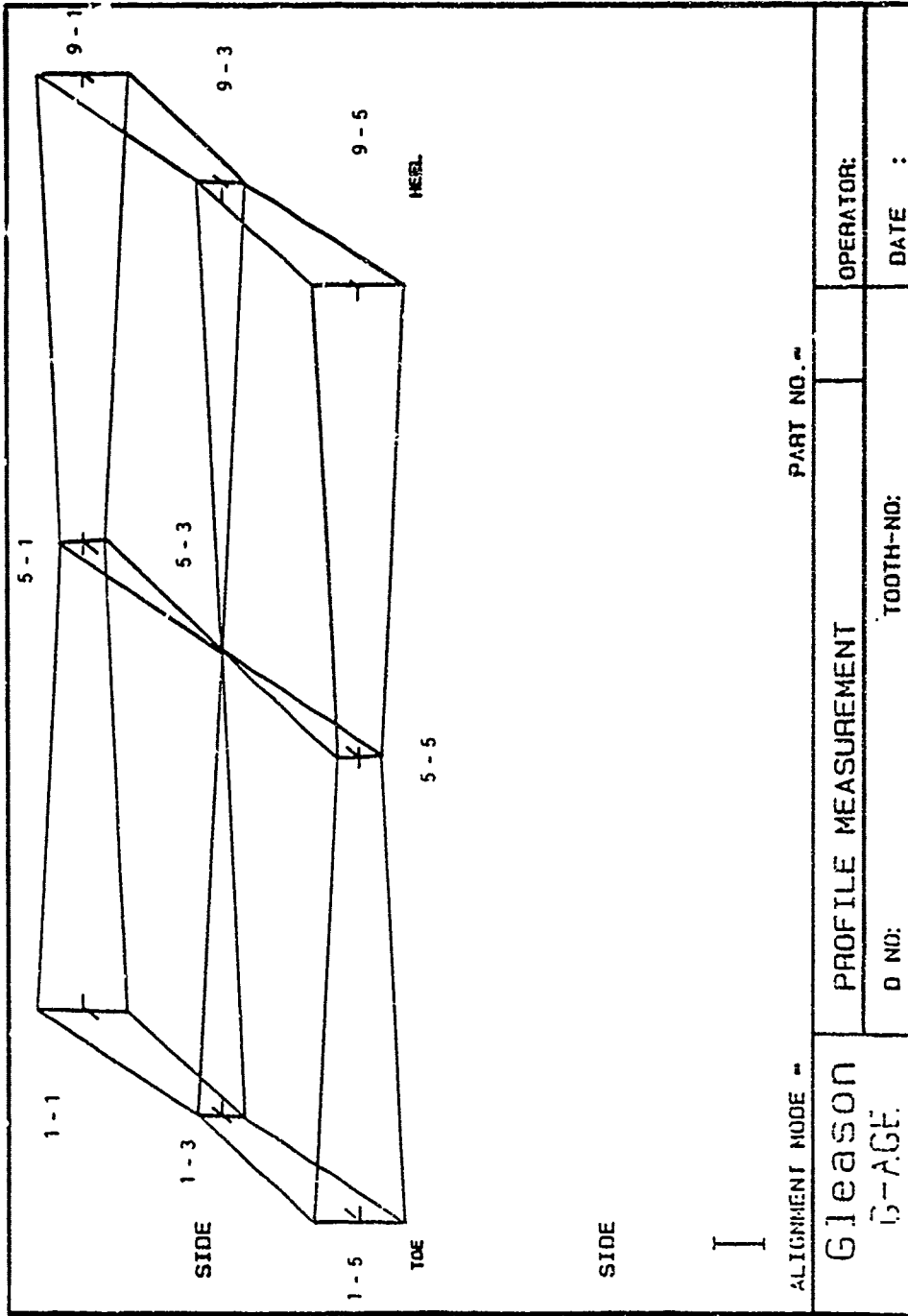

Figure 3. Tolerance Overlay Chart

IMPLEMENTATION PLAN  
AUTOMATED INSPECTION AND PRECISION GRINDING OF SPIRAL BEVEL GEARS

Sikorsky Aircraft has completed the technical effort of the U.S. Army AVSCOM project to develop and document an improved automated method for the final and in-process inspection of spiral bevel gears. This improved manufacturing method, which utilizes a multiaxis coordinate measuring machine, was found to be technically successful with significant cost savings, and proved to be an effective processing technique for maintaining the desired control of spiral bevel gear tooth geometry.

Sikorsky now plans to implement this inspection process for the UH-60A BLACK HAWK and the SH-60B SEAHAWK production spiral bevel gears manufactured at Sikorsky. A schedule and milestone chart for this implementation is shown in Enclosure (1). This plan is based on the assumption that the Zeiss UMM 500 Coordinate Measuring Machine, provided by the U.S. Army, and presently installed at Sikorsky, will be retained on a rent-free basis and converted to production usage. A second machine (Zeiss ZMC 5500), required to effectively support the BLACK HAWK and SEAHAWK production rates, will be purchased and installed with capital funding. As noted in the chart, approval of the capital appropriation request has already been received. The first aircraft with the improved process control gears is expected to be delivered in July 1987 on UH-60A Aircraft No. 996 and SH-60B Aircraft No. 91.

The controlling gear manufacturing specification, SES 50654, will be modified and revised to include this new inspection technique, initially as a recommended alternate to the present Gleason taping procedure. Our gear suppliers are being encouraged to adopt this new inspection method as well; however, in many cases, it is not economically feasible for them to do so at this time. The approach to be followed in the Sikorsky gear production facility will be to use both inspection methods in parallel for a short trial period (not to exceed 3 months) before converting 100 percent to the automated system. No additional material or mechanical testing is anticipated for this implementation although training of additional production personnel will be required.

The Quality Assurance plans, Quality Assurance Technical Instruction (QATI) 3055 and QATI 3039; the procedures for grinding, inspection and recording of data for spiral bevel gears; will be revised to include the automated inspection process once the requirement and effectivity of implementation is set by the appropriate revision to SES 50654.

A breakdown of the Sikorsky Aircraft costs involved in the implementation of the improved inspection process at Sikorsky is shown below.

Zeiss ZMC 550 system equipment and software, including technical training and tooling	\$424,000
Installation	25,000
Preparation and modification of a "clean" room	50,000
Development of special analysis file for BLACK HAWK and SEAHAWK production spiral bevel gears	<u>8,000</u> \$507,000

The implementation of this improved manufacturing process will improve the quality of spiral bevel gears produced at Sikorsky with fewer rejection rates traceable to nonconforming tooth profiles. This effect is achieved with significant manufacturing cost savings and will result in longer life gears requiring fewer spares.



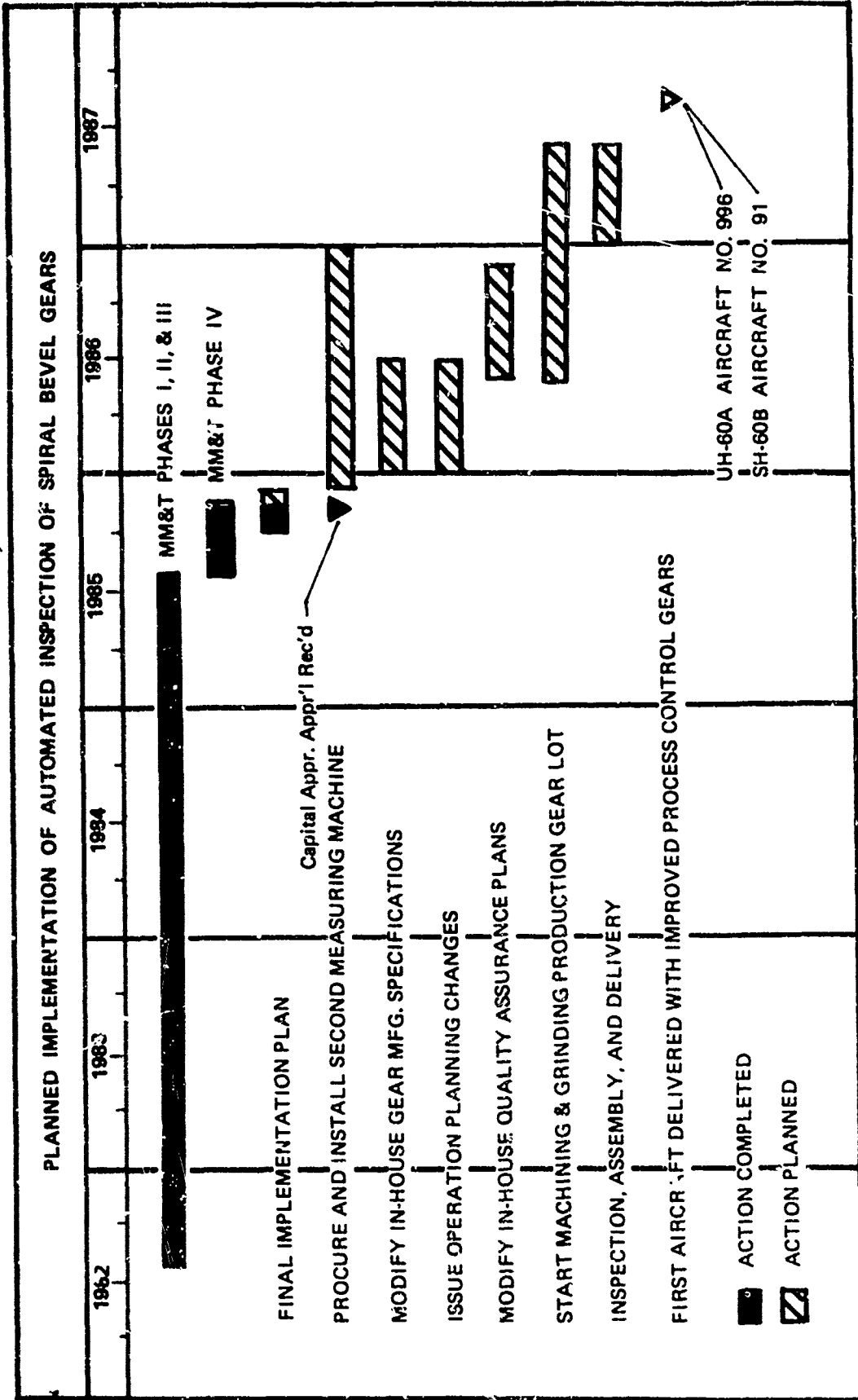

1. Report No. NASA CR-4083 AVSCOM TR 37-C-11		2. Government Accession No.		3. Recipient's Catalog No.	
4. Title and Subtitle  Automated Inspection and Precision Grinding of Spiral Bevel Gears				5. Report Date  July 1987	
				6. Performing Organization Code	
7. Author(s)  Harold Frint				8. Performing Organization Report No.  SER-510220 (E-3604)	
				10. Work Unit No. 1L162209AK76 505-62-OK	
9. Performing Organization Name and Address  Sikorsky Aircraft Division United Technologies Corporation Stratford, Connecticut 06602				11. Contract or Grant No.  NAS3-25465	
				13. Type of Report and Period Covered Contractor Report Final	
12. Sponsoring Agency Name and Address  U.S. Army Aviation Research and Technology Activity - AVSCOM, Propulsion Directorate, Lewis Research Center, Cleveland, Ohio 44135 and NASA Lewis Research Center, Cleveland, Ohio 44135				14. Sponsoring Agency Code	
15. Supplementary Notes  Project Managers, Daniel Pauze and Robert F. Handschuh, Propulsion Directorate, U.S. Army Aviation Research and Technology Activity - AVSCOM, Lewis Research Center.					
16. Abstract  This report presents the results of a four-phase MM&I program to define, develop, and evaluate an improved inspection system for spiral bevel gears. The improved method utilizes a multi-axis coordinate measuring machine which maps the working flank of the tooth and compares it to nominal reference values stored in the machine's computer. A unique feature of the system is that corrective grinding machine settings can be automatically calculated and printed out when necessary to correct an errant tooth profile. This new method eliminates most of the subjective decision making involved in the present method, which compares contact patterns obtained when the gear set is run under light load in a rolling test machine. It produces a higher-quality gear with significant inspection time and cost savings.					
17. Key Words (Suggested by Author(s))  Spiral bevel gears Gear manufacturing Gear inspection			18. Distribution Statement  Unclassified - unlimited STAR Category 37		
19. Security Classif. (of this report) Unclassified		20. Security Classif. (of this page) Unclassified		21. No. of pages 81	22. Price* A05