

Datum Reference Frame

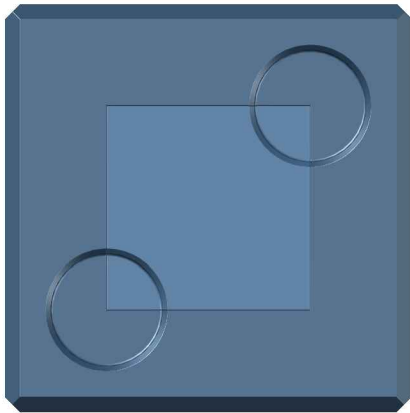

Bore Pattern (4x)

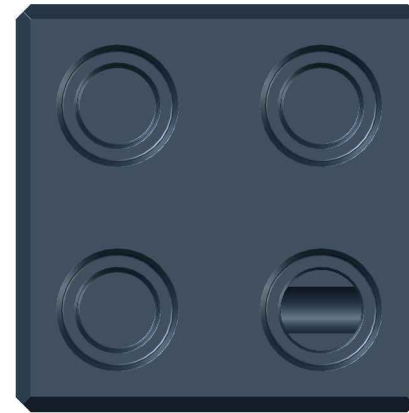

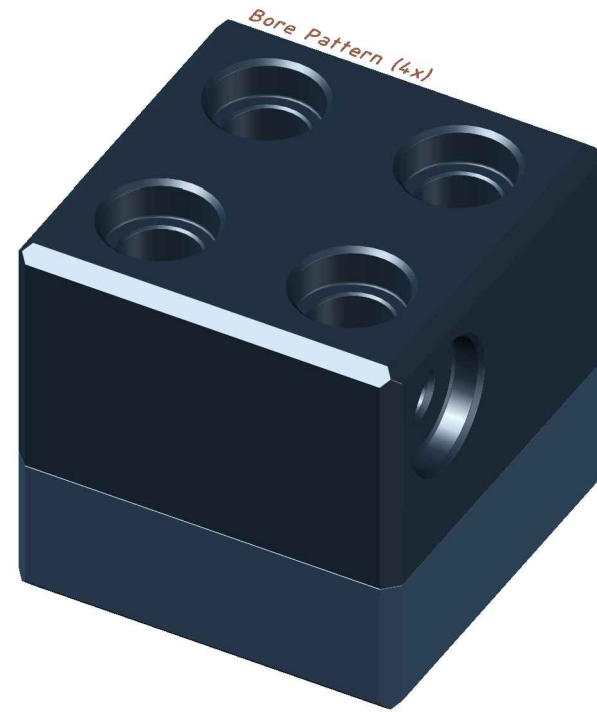
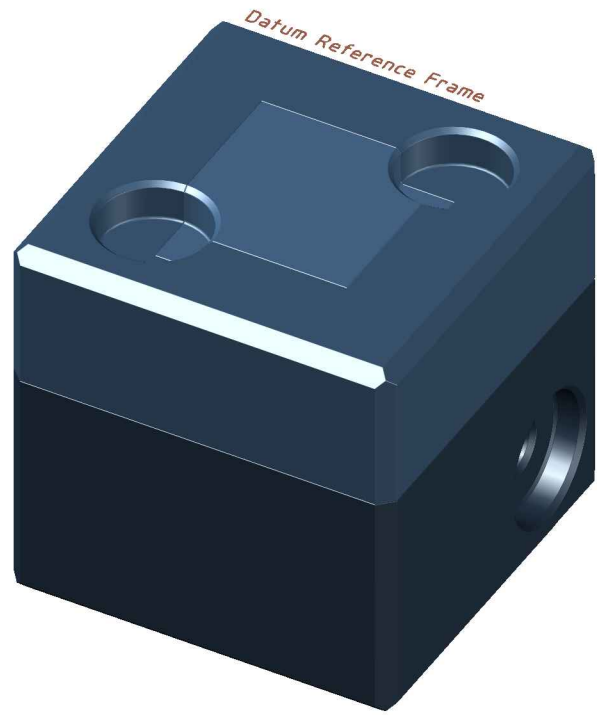

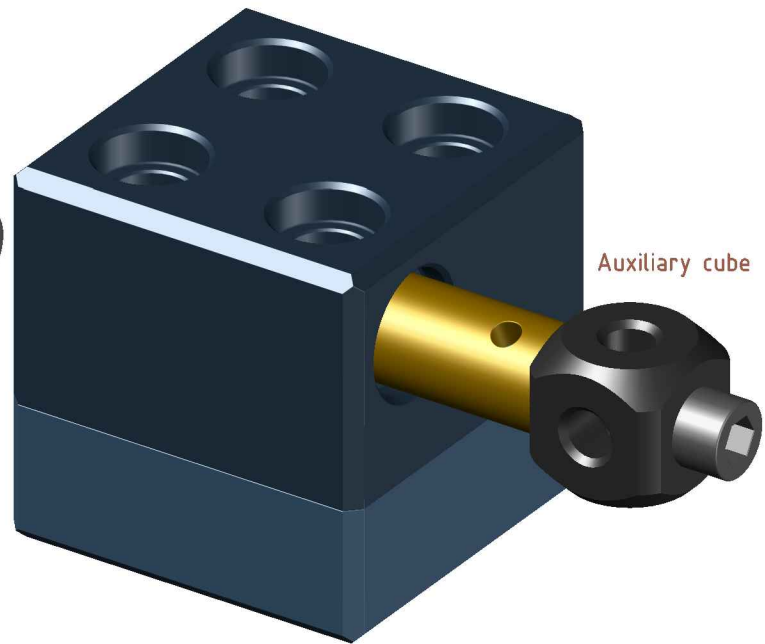
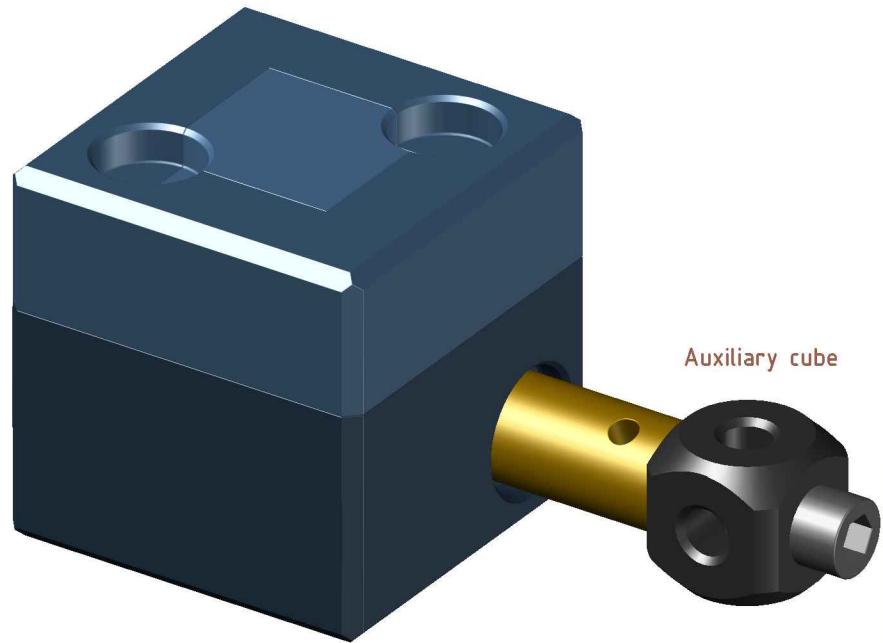

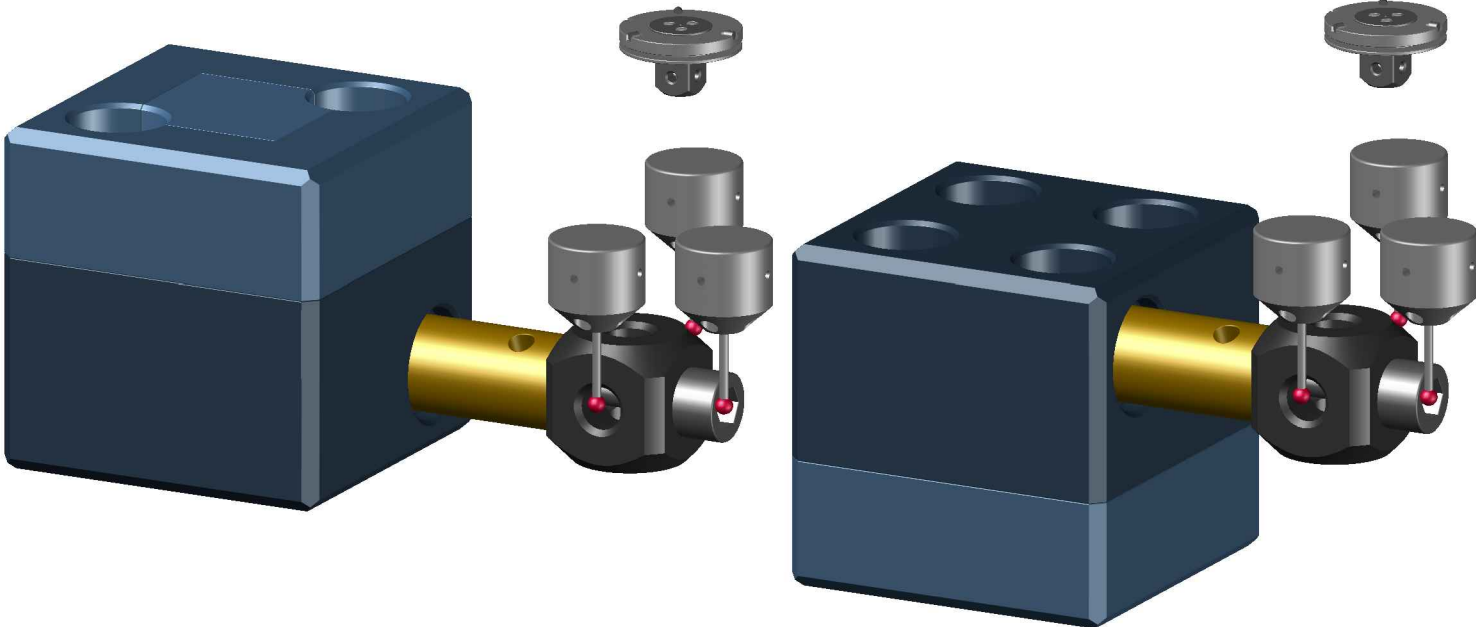

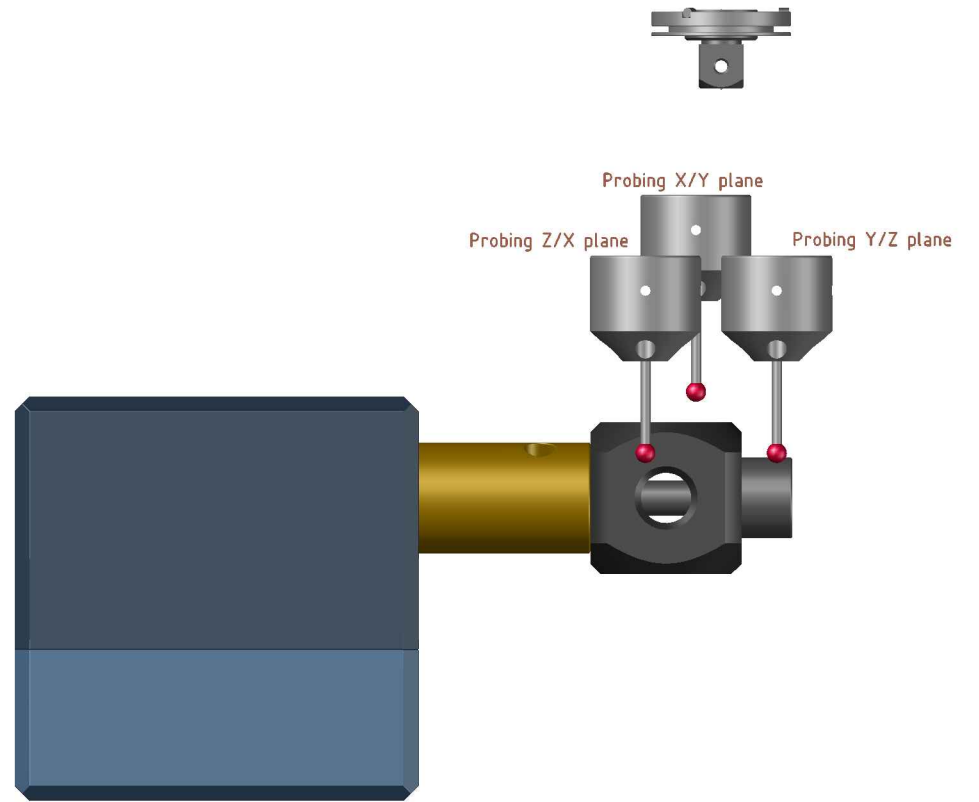
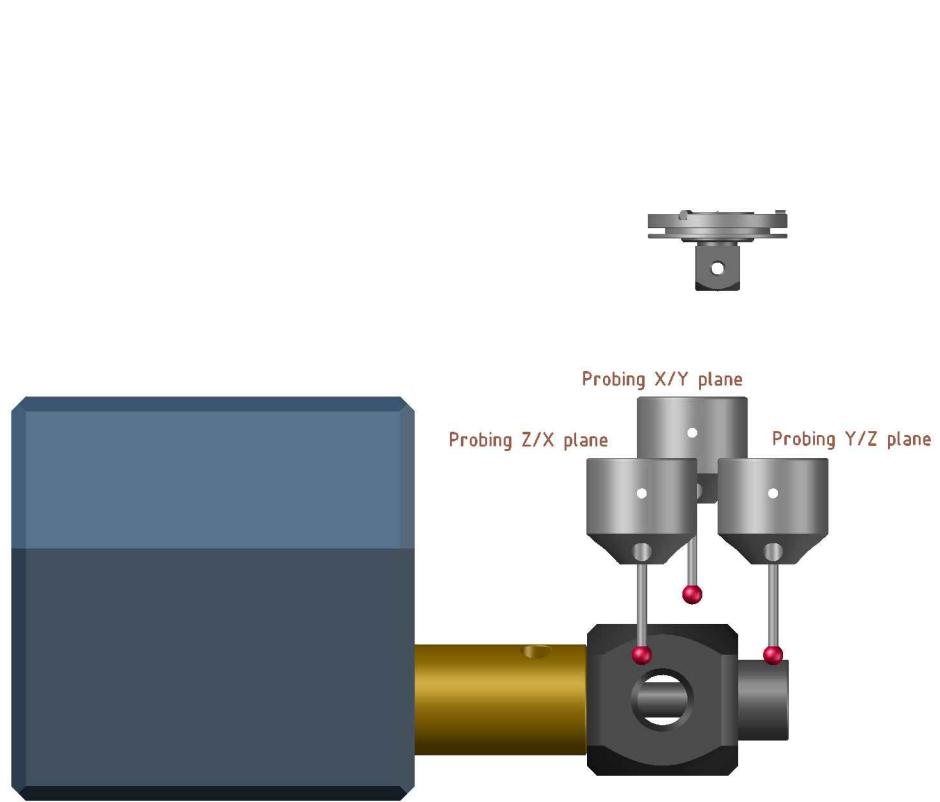

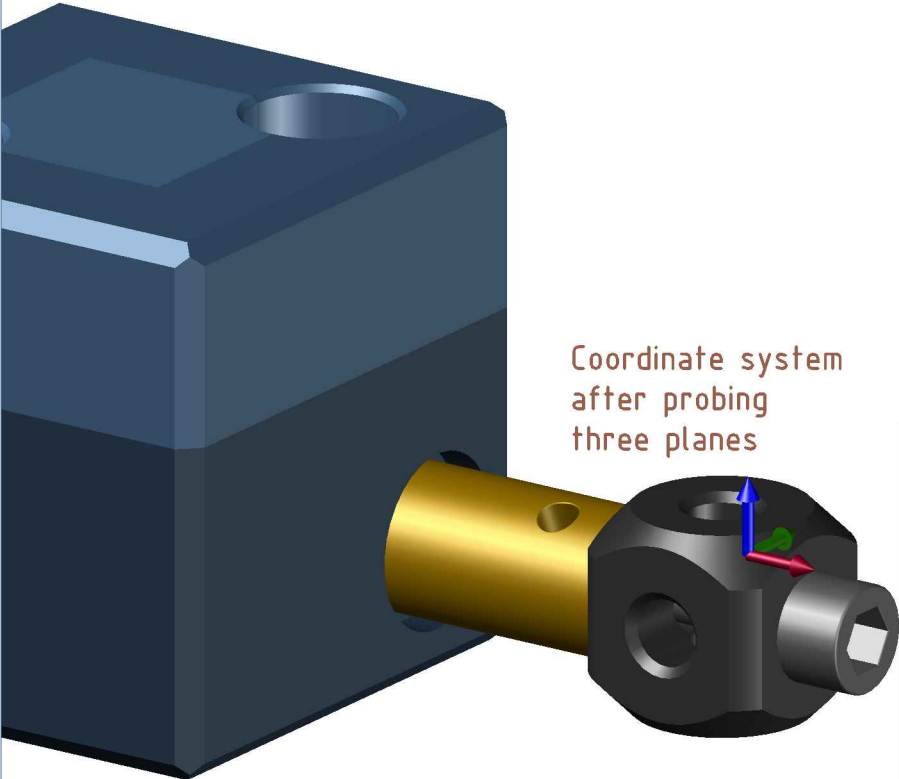

Coordinate system
after probing
three planes

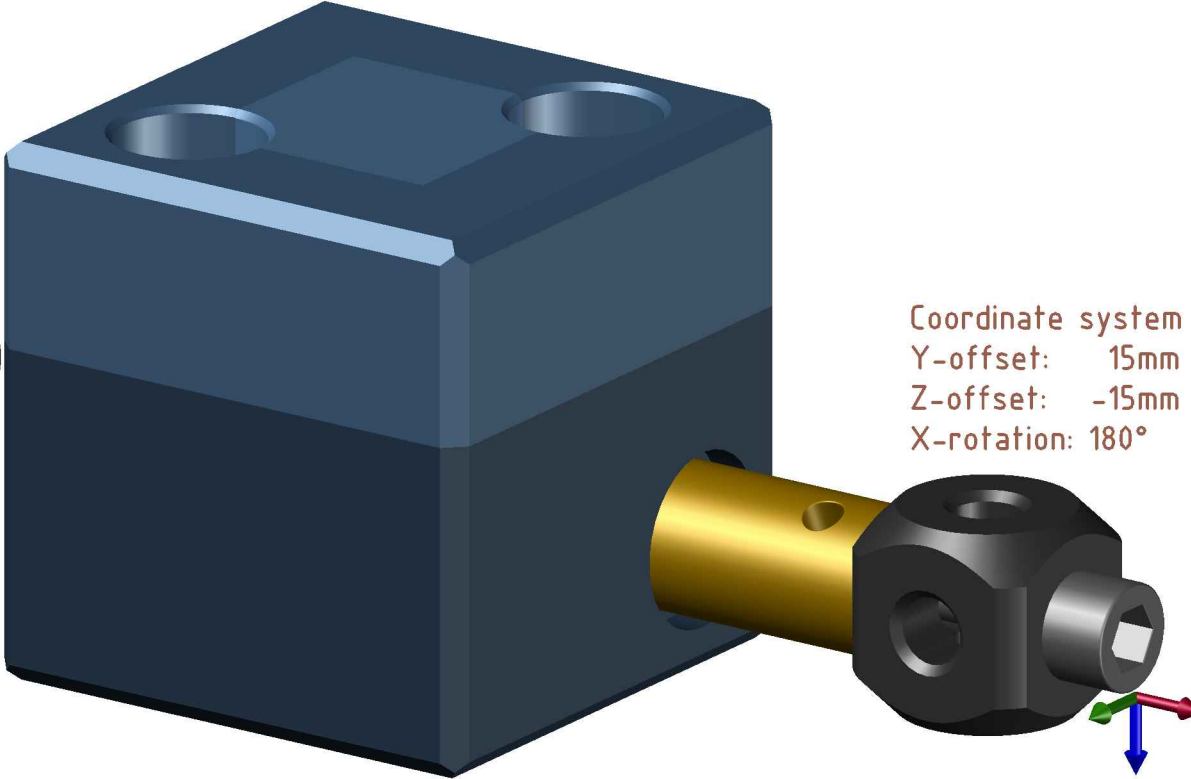

Coordinate system
Y-offset: 15mm
Z-offset: -15mm
X-rotation: 180°

