

Fillet Radius and dimensioning

Pic. #1

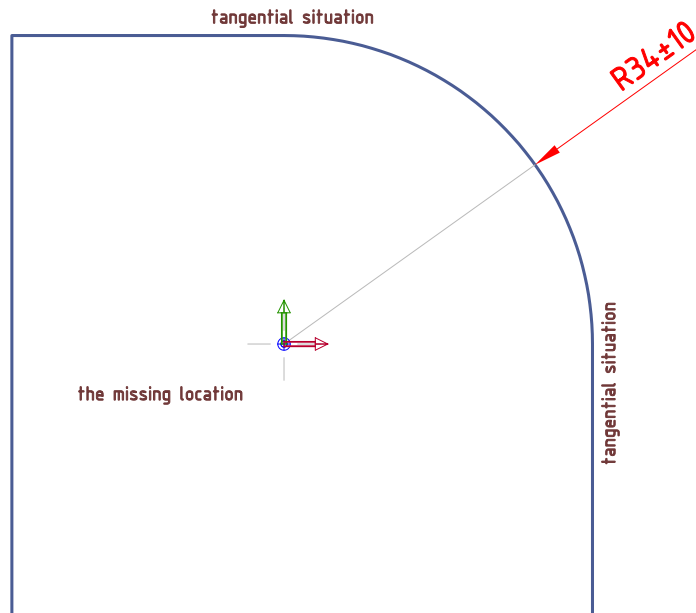

All points are located within the tolerance zone.
The "Decreasing form error"
Unrealistic scenario.

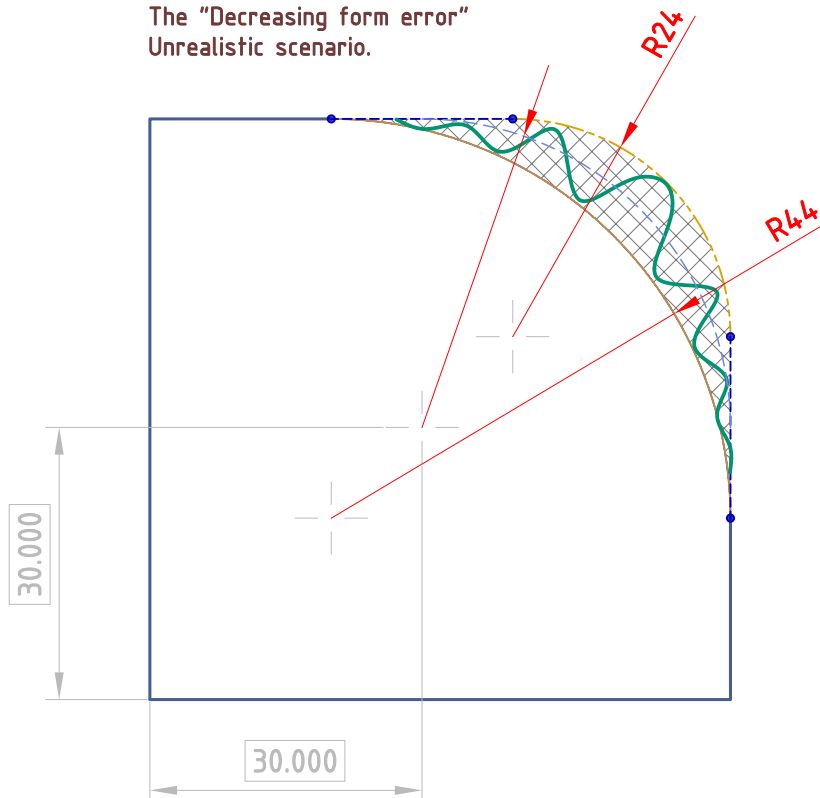

Profile Tolerance (alternative)

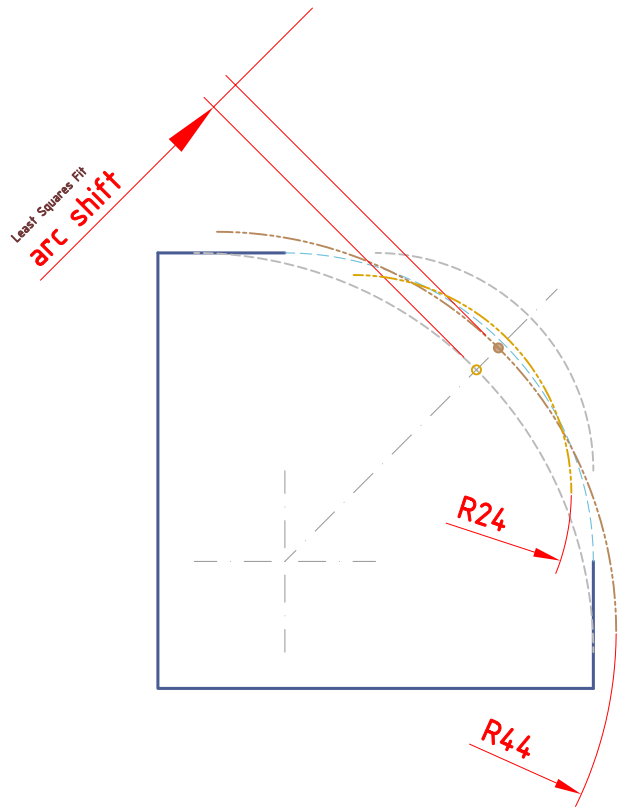
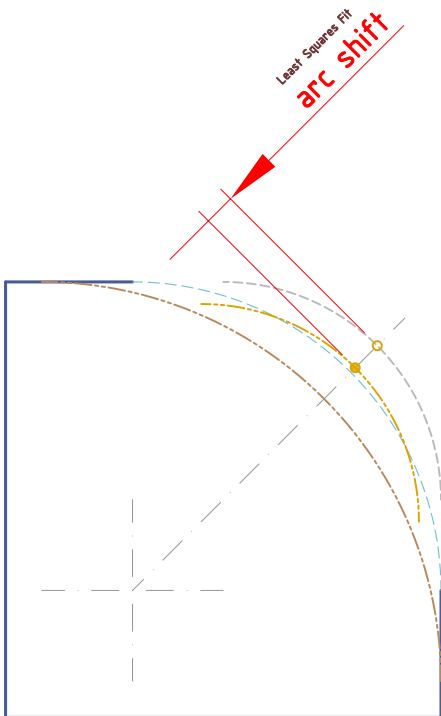
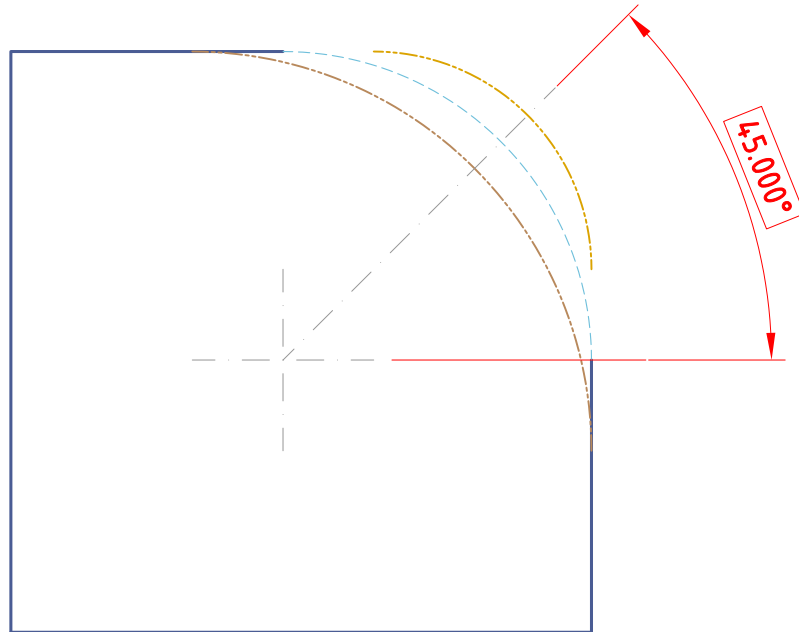

Profile Tolerance (alternative)

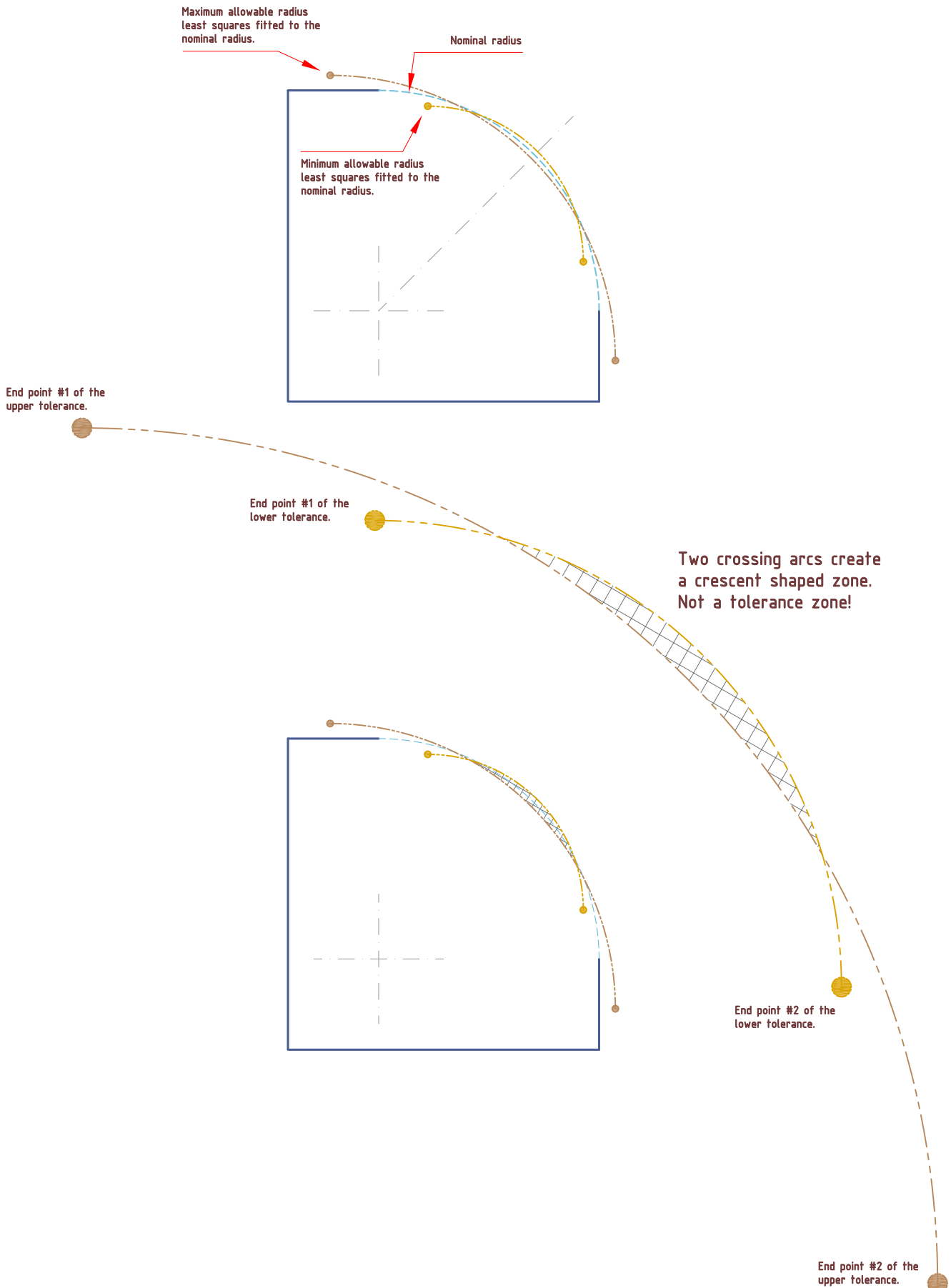

Fillet Radius and dimensioning

Pic. #4

Profile Tolerance (alternative)

Tolerance zone for Profile.

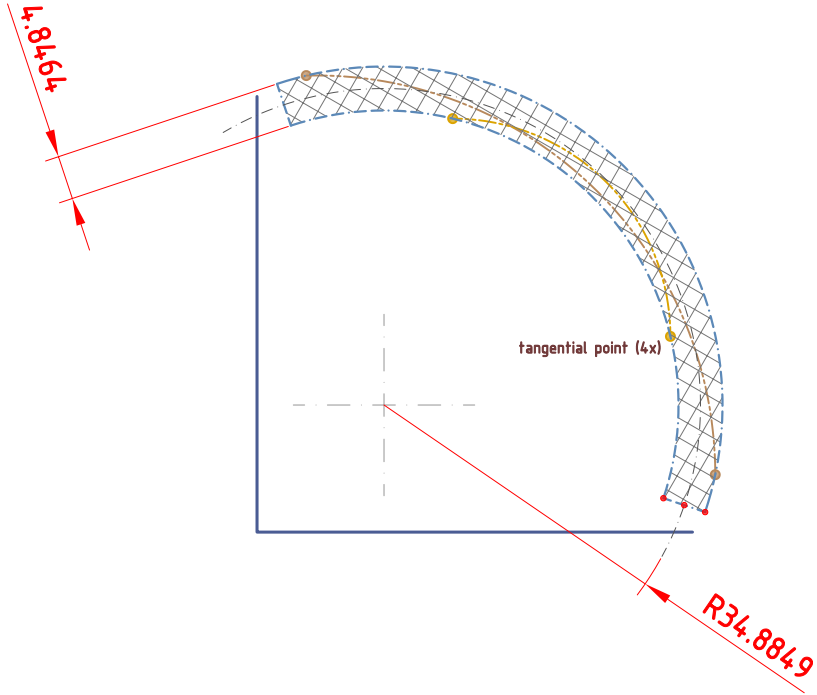

Nominal radius:
R34.0000
Radius after fit:
34.8849
Difference:
0.8849

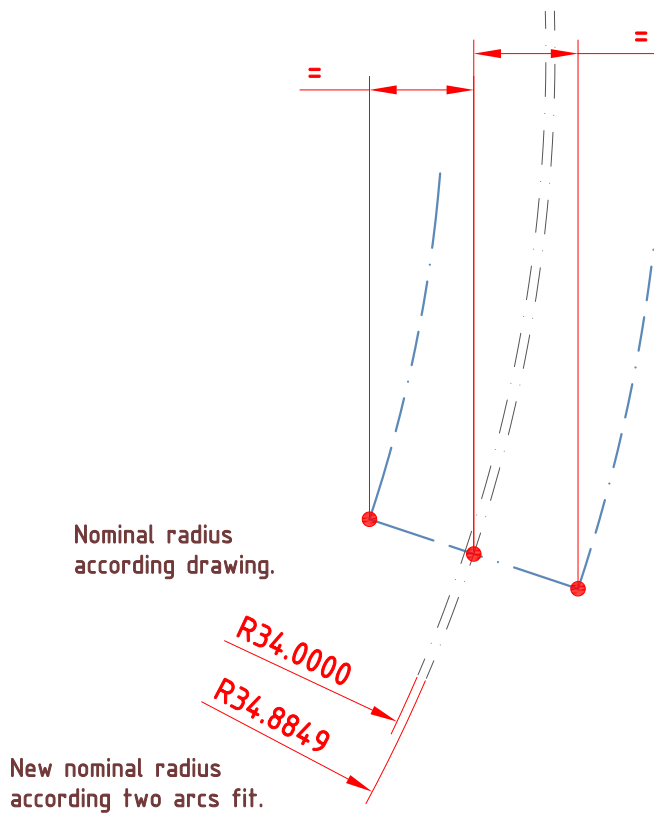

Nominal radius according drawing.

New nominal radius according two arcs fit.

Plus-Minus-Tolerance

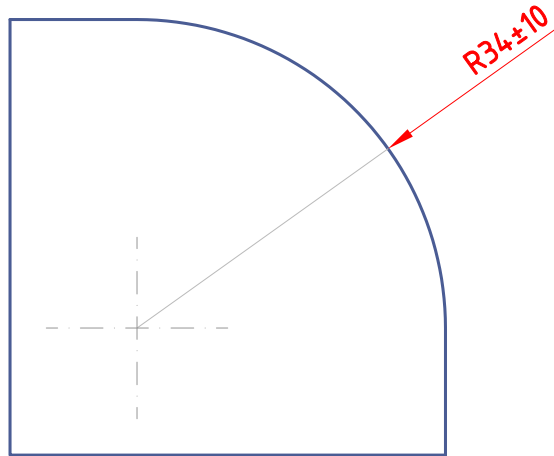

Profile Tolerance #1 (alternative)

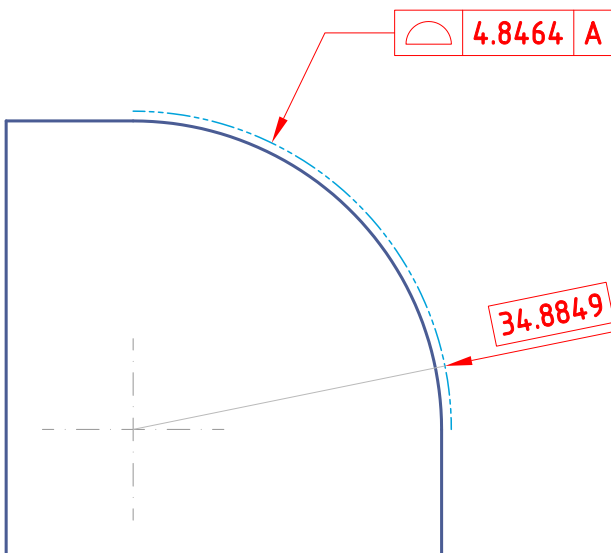

Profile Tolerance #2 (alternative)

