

Another option and more control to output the features table from calypso.

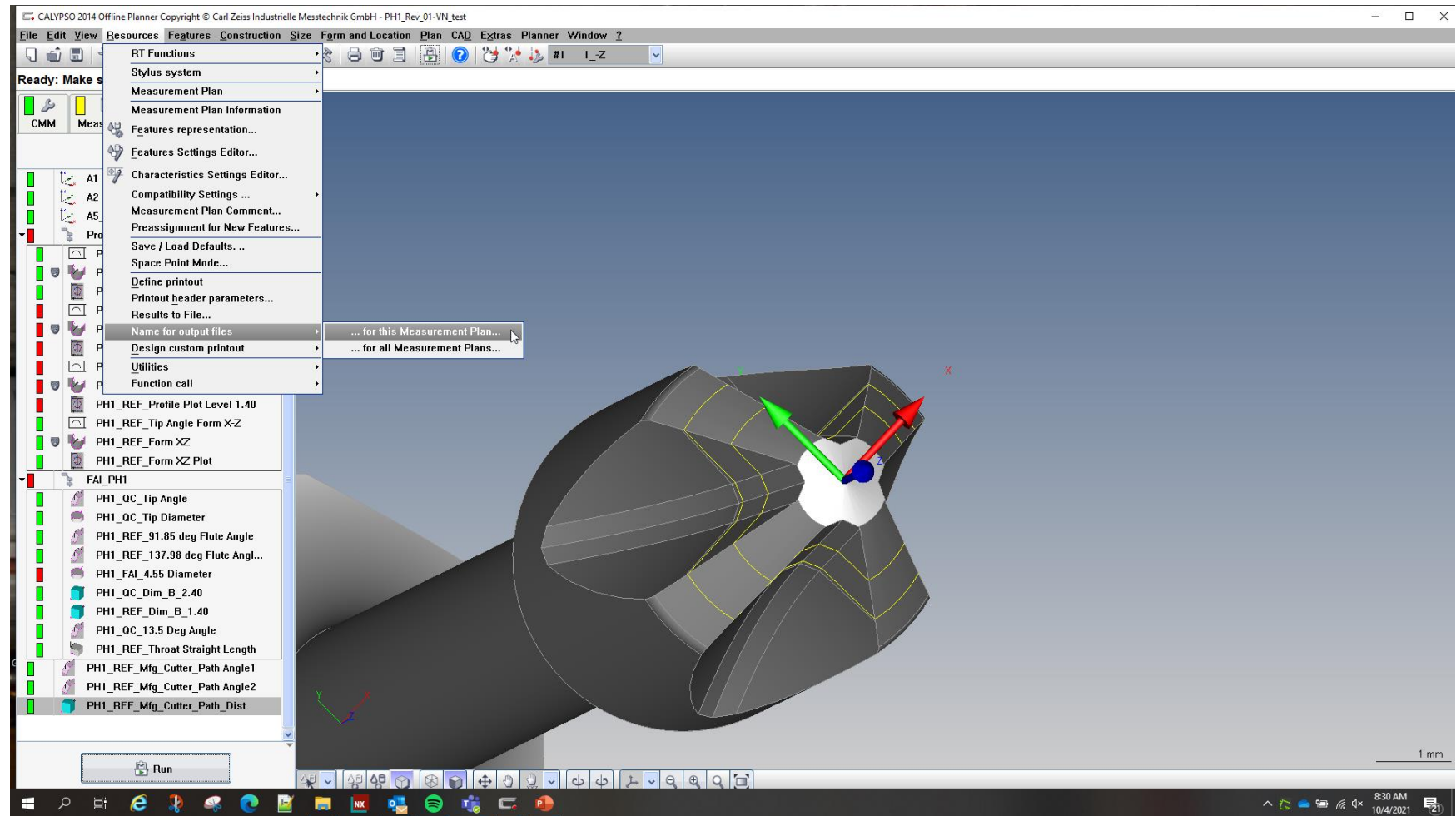

Output the features table, is the same as _fdr.txt file from Results to file in Calypso.

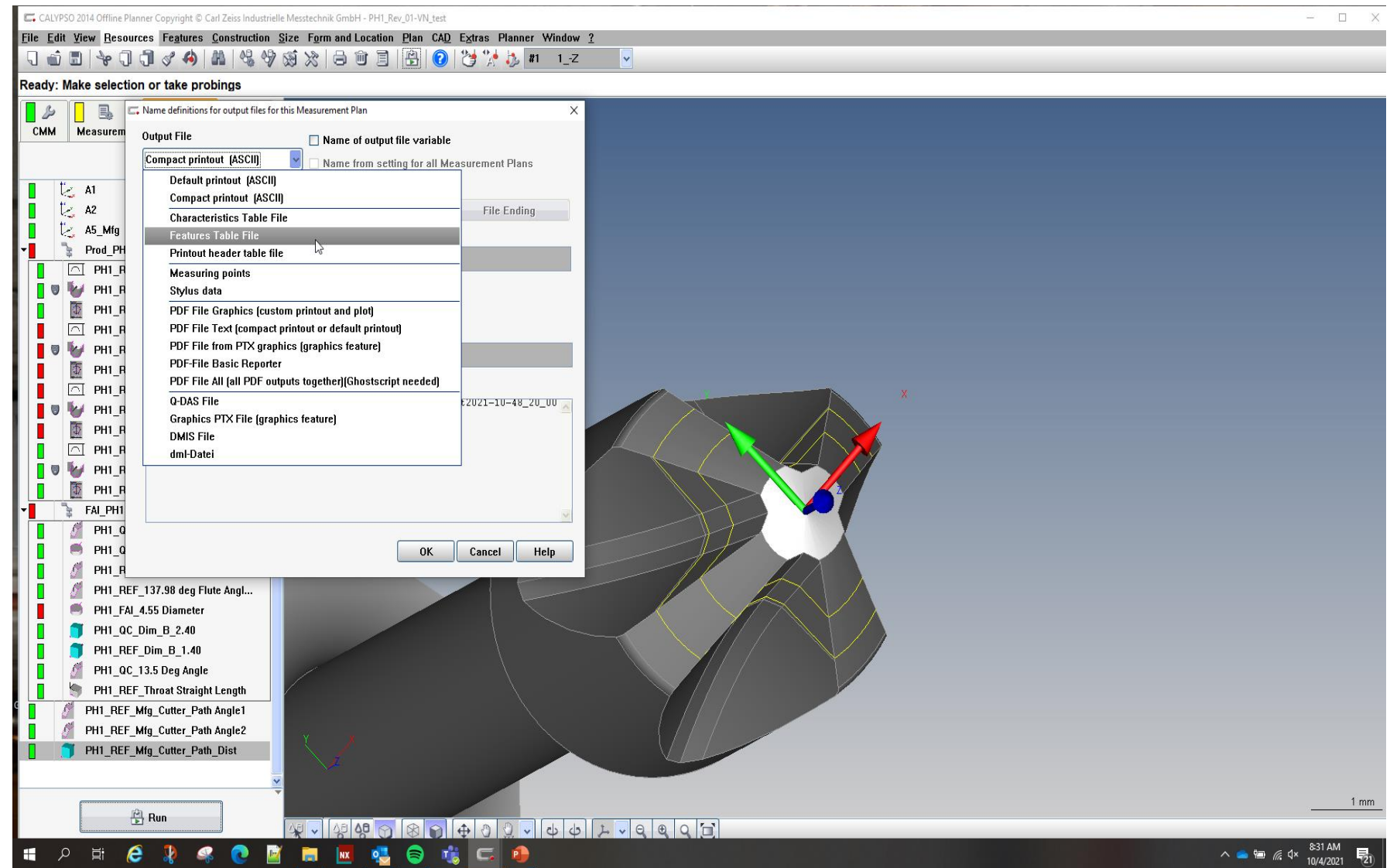

This is the same feature table being outputted here, but we can change the directory and naming of the text file.

This would be an easy update to our Calypso programs if we can do something like this using the Macro in Polyworks Inspector.

File output is:

PH1_Rev_01-VN_test_2021-10-4_11_06_48 am.txt

Needs to be like the following:

PH1 Rev 01-VN test_2021-10-04_110648.txt

